



# ADVANCE DIGITAL SECURITY SOLUTIONS

[WWW.CBCSINGAPORE.COM](http://WWW.CBCSINGAPORE.COM)



# Why choose Computar lenses and Ganz CCTV products?

There's something rather special about Computar lenses and Ganz CCTV products. Together, they are the perfect combination.

With Computar and Ganz, you can be sure of:

- Performance that often exceeds specifications
- Exceptional reliability
- A wide choice, where you'll find a product to suit most applications
- Consistency, innovation, and compatibility between products
- World-leading technology from a worldwide manufacturer

The Ganz illuminator, where you change the field of illumination to match the field of view of the camera. Or the Ganz DVR that has such a good memory about images that it can automatically identify if anything has been taken or moved.

All these make use of the technological skill and precision that goes into Computar lenses, to deliver the highest quality images.

No wonder Ganz products, with Computar lenses, are so popular.

This catalogue gives you the whole range of products available. Whatever the product, you'll be able to recommend and install it with complete confidence.

Tokyo HQ Registered



# CONTENTS

	Page
<b>Introduction</b>	
Developing Ganz Label	4
<b>CS Mount Cameras</b>	
ZC-Y Series	5
ZC-NH258P	6
ZC-NH258PM	8
<b>Dome Cameras</b>	
ZC-D5000 Series	10
ZC-D7000 Series	12
<b>Motorised Zoom Lenses</b>	
H60Z1238A-IRF	14
H35Z2030AMSP	15
H30Z1015AMSPR	16
T34Z5518AMSR-CS	17
T34Z5518AMSPR-CS	18
T34Z5518PDC-CS	19
T34Z5518DC-CS	20
T21Z5816AMSP-CS2	21
T21Z5816PDC-CS	22
<b>Mechanism and Advantageous</b>	
Effect of IR Lens	23

## Developing the GANZ label in the Security Systems Industry

Aside from being the world leader in CCTV lenses, CBC also makes CCTV cameras under the GANZ brand name, based on their own unique specifications. In a monitoring report by a U.S. technical magazine specializing in CCTV, GANZ was ranked at the top in all the areas it was tested for, including performance in such categories as angle and brightness, and also for maintenance and service.

In addition to cameras, CBC also distributes monitors, multiplexers and switchers that are manufactured under the GANZ label. CBC offers one-stop shopping for all security system needs by supplying all the major equipment necessary. Because of this, it has been praised by customers for its convenience.

### *First Surveillance Camera to Increase Visibility in Adverse Environments!*

**January 11, 2010, Commack, NY** – CBC announced the **Ganz® THRU Vision Series** of cameras and lenses, engineered to sharpen and increase visibility in conditions where fog, haze, smog, sand or rain impede outdoor video surveillance. The “MIST” technology, pioneered by CBC and the first of its kind, can be used for mission-critical perimeter surveillance, port, harbor and airport security applications.

The real-time MIST technology of the **Ganz® THRU Vision Camera** works with any C/CS-mount lens, by focusing through obstacles present in the atmosphere that can obstruct or deteriorate video image quality (i.e. fog, rain, haze, smoke or snow). The camera’s dynamic range control (DRC) function detects and measures image intensity on the screen. By digitally adjusting color and contrast, poor quality images caused by environmental factors are automatically corrected. Digital and True Day/Night models are available.

For extreme long distance surveillance, the **THRU Vision Camera** can be paired with the **Computar® THRU Vision 60X Loom Lens** (25-1500mm w/extender) to clear obstacles and provide images clearer than the human eye. Lens technologies previously available were not able to reproduce color images, or focus through solid particles like smoke, sand or snow.

The inclusion of GANZ products along with its Number One Computar brand of lenses is what has made customers recognize CBC as a manufacturer within the CCTV industry. The key reason behind CBC’s success, is the value it has to offer its customers. The Company’s pursuit for value crosses various industries.



Minidome camera



Security camera



GANZ booth at a security trade show

## ZC-Y SERIES

### Super High Resolution Colour Cameras



#### Key Features

- 1/3" IT CCD
- Super high resolution (540 TVL)
- Outstanding picture quality
- Electric iris function
- Advanced digital signal processing
- Built in "Auto iris amplifier"
- Easy focus adjustment
- Back light compensation
- Automatically switchable
- 12VDC / 24VAC for ZC-Y12PH4 only

ZC-Y12/15 series are new super high resolution, compact colour cameras suitable for almost all applications where there is a strong emphasis on outstanding picture quality with detail.

The high performance CCD image sensor combined with the new Digital Signal Processing chip delivers a super high resolution of 540 TVL.

Extensive features are standard on this range of cameras such as advanced digital signal processing, auto iris amplifier, internal or line lock synchronization, complete with phase adjustment, automatic gain control, auto electronic shutter, auto white balance correction and backlight compensation.

The cameras are available in mains or low voltage versions. The low voltage model allows both AC & DC connection providing greater versatility and is also automatically switchable.

#### Ordering Information

- ZC-Y15PH3** Super High Resolution Camera, Colour. 230V
- ZC-Y12PH4** Super High Resolution Camera. Colour, 12VDC - 24VAC

#### Technical Specification

Model	ZC-Y15PH3	ZC-Y12PH4
TV System	PAL	
Lens Mount	CS Mount	
Image Sensor	1/3" IT CCD	
Effective Elements	752(H) x 582(V)	
Video Output	1.0V (p-p) / 75 ohm	
Resolution (Horizontal)	540 TVL	
Minimum Illumination (F1.2/50IRE)	1.2 lux (D D/N off), 0.8 lux (D D/N on)	
(F1.2/30IRE)	0.62 lux (D D/N off), 0.4 lux (D D/N on)	
S/N Ratio	More than 50dB (AGC OFF)	
Gamma Characteristics	0.45	
Sync. System	INT. / Line-lock	
Iris Control	DC: DC iris AES (Sec): Linear shutter (1/50 to 1/20000) Video: Vcc = DC 12V, 50mA max, Sig = 0.7 V(p-p) High impedance	
Scanning Frequency	15.625kHz (H) / 50.0Hz (V)	
White Balance	ATW	
Operating Temperature & Humidity	-10 to +50 Degrees C, 85% RH Max. (No Condensation)	
Storage Temperature & Humidity	-20 to +60 Degrees C, 95% RH Max. (No Condensation)	
Power Supply	230VAC	12VDC / 24VAC Auto Switching
Power Consumption	4.5W or less	
Weight (approximate)	270g	
External Dimensions	60(W) x 54(H) x 103.3(D)mm	
Switches	Iris Control: DC/AES/VIDEO BLC: BLC/OFF D D/N: ON/OFF Video Output: BNC/UTP (only ZC-Y11PH5 model)	
Adjustments	DC iris level adjustment (adjustable POT in only DC iris model)	

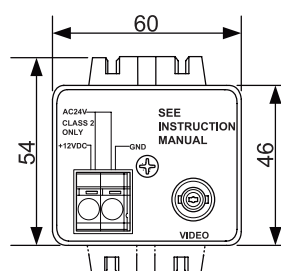

Back Panel

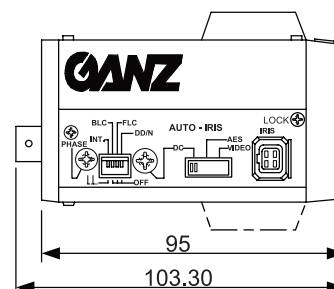

Side Panel



## ZC-NH258P

### Super High Resolution Colour/Mono Cameras



#### Key Features

- 1/3" IT CCD with advanced DSP chip
- 540 TVL Super High Resolution
- More than 50dB S/N ratio (AGC off)
- High sensitivity with minimum illumination and IR sensitive
- Excellent picture quality in both day and night mode
- Fast Day / Night switching (less than 1.5sec)
- Automatic Gain Control
- Built in "Auto iris amplifier"
- Backlight compensation
- Auto-sensing 12VDC / 24VAC power

The ZC-NH258P camera is a super high resolution, true Day/Night, compact box camera that provides optimised sensitivity in both day and night shooting scenarios. As the illumination of the viewed scene reduces and the video image darkens, an IR cut filter is automatically removed and the camera switches to black and white mode, increasing the cameras sensitivity which then requires illumination of only 0.04 lux to provide an excellent night time image. The high performance CCD image sensor combined with the advanced Digital Signal Processing chip delivers a super high resolution of 540 TVL colour pictures during the day and sharp black and white pictures at night.

The camera is very versatile when it comes to lens selection, allowing the use of DC or Video drive automatic iris lenses and even manual iris lenses via use of the cameras automatic electronic shutter (AES) setting. This is where the CCD photo sensors exposure time is automatically adjusted and controlled by referencing the level of illumination in the scene.

Other extensive features included in the camera are: Internal or line lock synchronisation complete with phase adjustment, automatic gain control, auto white balance correction and backlight compensation.

The combination of the cameras 'True Day/Night' capability, the advanced DSP chip, its ability to work with automatic and manual iris lenses as well as the many other features included make this camera suitable for almost any internal or external application. This is a very simple to install, no fuss camera which is very easy to set-up and gives excellent results in a huge variety of lighting conditions.

#### Ordering Information

**ZC-NH258P** Super High Resolution Colour/Mono Camera  
12VDC / 24VAC

# ZC-NH258P

## Super High Resolution Colour/Mono Camera

### Technical Specification

Model	ZC-NH258P	
TV System	PAL	
Lens Mount	CS Mount (c mount with optional 5mm adapter)	
Image Sensor	1/3" IT CCD, complementary colour mosaic filter	
Effective Elements	752(H) x 582(V)	
Video Output	1.0V (p-p) / 75 ohm	
Scanning System	2:1 interface	
Resolution (Horizontal)	540 TVL	
Minimum Illumination	(F1.2/50IRE)	1.2 lux (Colour), 0.08 lux (Mono)
	(F1.2/30IRE)	0.62 lux (Colour), 0.04 lux (Mono)
	With IR Illumination	0.00 lux
S/N Ratio	More than 50dB (AGC OFF)	
Gamma Characteristics	0.45	
Sync. System	INT. / Line-lock	
Iris Control	DC: DC iris	
	AES (Sec): Linear shutter (1/50 to 1/20000)	
	Video: Vcc = DC 12V, 50mA max	
Scanning Frequency	15.625kHz (H) / 50.0Hz (V)	
White Balance	AWB/ATW	
Operating Temperature & Humidity	-10 to +50 Degrees C, 85% RH Max. (No Condensation)	
Storage Temperature & Humidity	-20 to +60 Degrees C, 95% RH Max. (No Condensation)	
Power Supply	12VDC / 24VAC Auto Switching	
Power Consumption	4.5W or less	
Weight (approximate)	270g	
External Dimensions	60(W) x 54(H) x 103.3(D)mm	
Switches	Iris Control: DC/AES/VIDEO	
	BLC: ON/OFF	
	FLC: ON/OFF	
Adjustments	Line lock phase adjustment	
	DC Iris level adjustment (adjustable POT in only DC Iris model)	

\* FLC is valid for the DC iris and Video iris control modes.

Features and specifications are subject to change for further improvement without any notice.

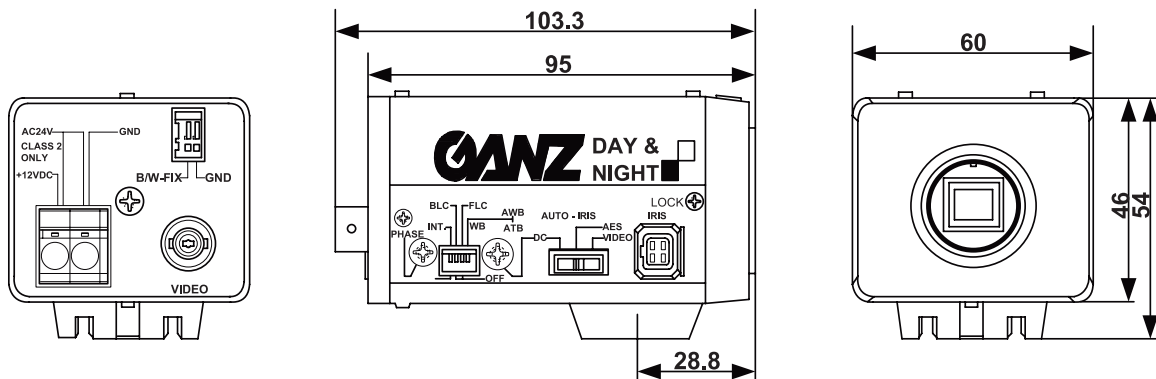

### THRU Vision solution

In foggy, rainy, sandy or air polluting environments, CBC's 'THRU Vision' solution provides clearer and sharper images. The new THRU Vision package of lens and camera produces more vivid images and colours than the human eye can achieve. To achieve this, a new Computar 60x zoom lens is

equipped with a unique filter which helps see better objects which may otherwise be hidden behind obstacles. The lens is fitted to a new GANZ day/night camera which also helps to provide images of scenes behind these obstacles.

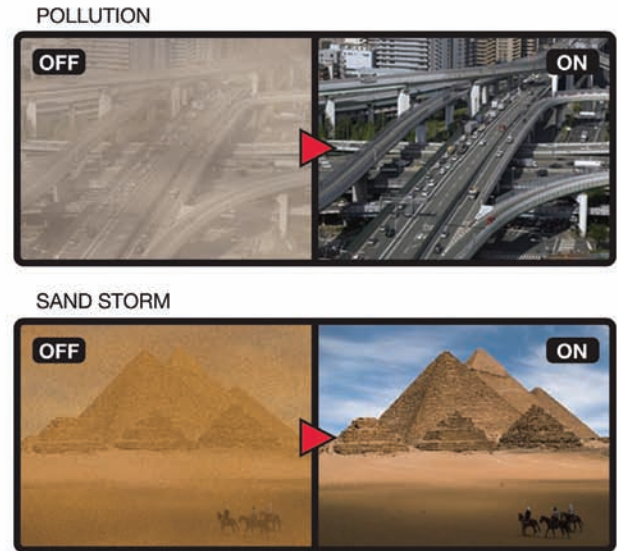
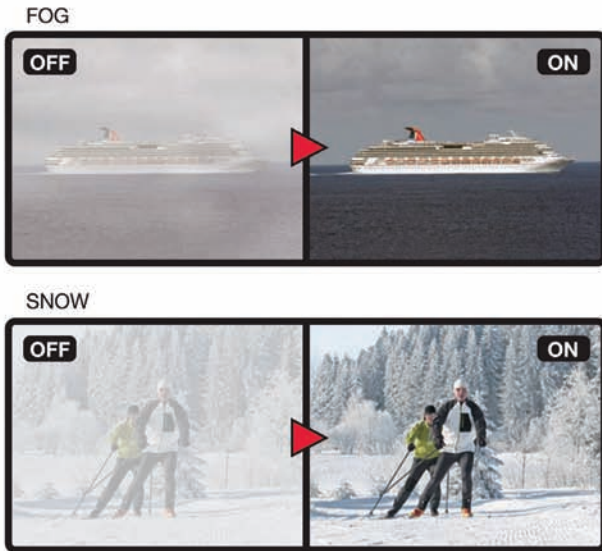

\*Images above for illustration purpose only.

### THRU Vision camera

With its new image correction technology, low contrast images caused by poor visibility environments such as fog, mist, rain or snow are digitally processed by the THRU Vision camera into high quality images, with the contrast and colour elements automatically adjusted. The camera's dynamic range control (DRC) function detects and measures bright and dark areas on the screen and automatically makes adjustments by brightening or darkening the scene respectively. The Day/Night function provides high quality images in both day and night environment by allowing the camera to function as a vivid colour camera in daylight conditions and as a high sensitivity black and white camera when lighting conditions are low.





## THRU Vision camera

Model		ZC-NH258Pm (Mechanical Day & Night)
TV System		PAL
Scanning System		2:1 interlace
Image Sensor		1/3 type Interline transfer CCD, complementary color mosaic filter
Effective Elements		752(H) x 582(V)
Scanning Frequency		15.625kHz (H) / 50Hz (V)
Video Output		1.0V (p-p) / 75Ω
Resolution (Horizontal)		More than 540 TVL
S/N Ratio		More than 50dB (At minimum AGC gain, GMIST OFF)
Gamma Characteristics		0.45
Minimum object illumination at F1.2	50IRE	0.04 lx (Night mode, B/W)
	30IRE	0.02 lx (Night mode, B/W)
	With IR Illuminance	0.00 lx (Night mode, B/W)
Sync. System		Internal synchronization (INT.)
Electronic Shutter		1/50 sec. fixed (Flickerless: OFF) 1/20 sec. fixed (Flickerless: ON)
Iris Control	DC:	DC iris
	AES (sec):	Linear shutter (1/50 to 1/20000)
	VIDEO:	Vcc = DC 12V, 50mA max. Sig. = 0.7V (p-p) High impedance
GMIST		ON / OFF selectable
GMIST Mode		STD mode / AUTO mode selection
GMIST Level		STD / HIGH selectable
Dynamic Range Control (DRC)		STD fixed at STD mode, STD / HIGH selectable at AUTO mode
Backlight Compensation (BLC)		ON / OFF selectable
Flickerless Control (FLC)		ON / OFF selectable
White Balance Control (WB)		ATW / AWB
Digital Day & Night Control		-
Power Supply		AC24V±10% (50Hz±1Hz) or DC12V±10%
Power Consumption		5W or less
Lens Mount		CS mount ( C mount with optional 5mm adapter)
Operating Environment		-10°C to +50°C, 85% RH or less (no condensation)
Storage Environment		-20°C to +60°C, 95% RH or less (no condensation)
External Dimensions		60(W) x 54(H) x 103.3 (D) mm
Weight		250g
Input / Output Terminals	Video Output:	BNC
	Auto-iris Output:	4-pin connector (D4-157J-250 / equivalent)
	Power input:	2-pin screwless terminal blocks
	B/W Mode-Fix:	2-pin screwless terminal blocks
Switches	Iris control:	DC / AES / VIDEO
	GMIST:	ON / OFF
	GMIST Mode:	STD / AUTO
	GMIST / DRC Level:	GMIST (STD / HIGH) at STD mode, DRC (STD / HIGH) at AUTO mode
	White Balance:	ATW / AWB
	Digital D/N (D D/N)	-
	* FLC	FLC (Fixed at 1/120 second) / OFF
	BLC	ON / OFF
Adjustable Volume		DC iris level adjustment (adjustment POT in only DC iris mode)

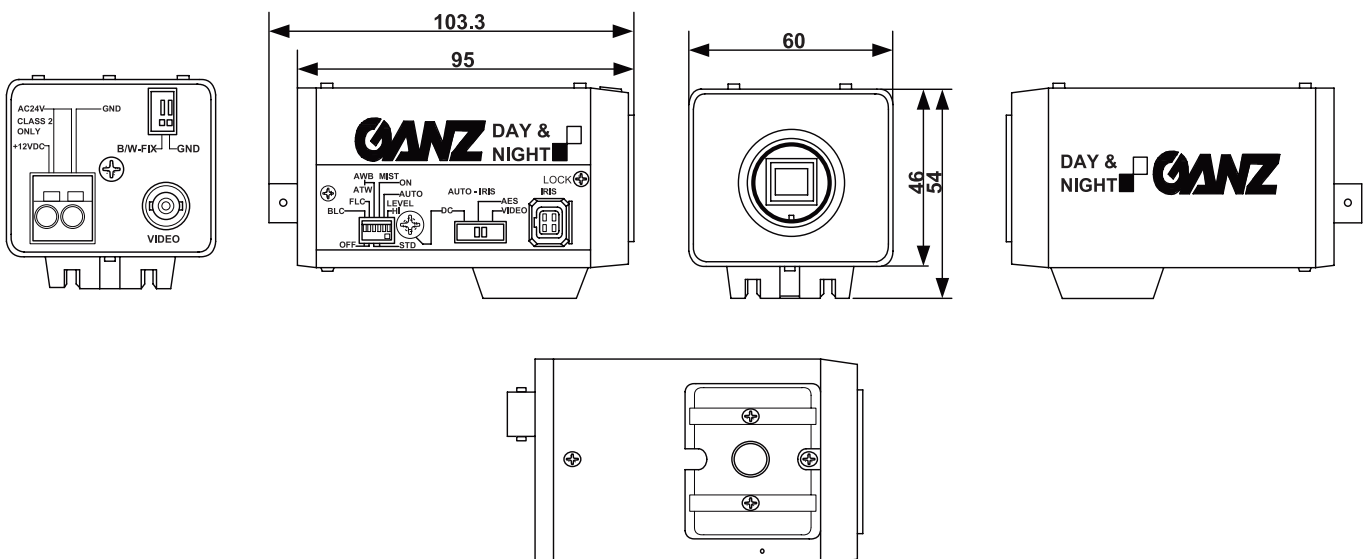

## ZC-D5000 Series

### Super High Resolution Colour & Colour/Mono Domes



#### Key Features

- 1/3" IT CCD
- Super High Resolution
- Integrated Varifocal lens
- Impressive colour reproduction
- Digital Signal Processing
- Day / Night version available
- Line lock with phase adjustment
- Backlight compensation
- Automatic gain control
- Easy adjustment with the unique 3 axis gimble.

The ZC-D5000 Dome camera has a high performance CCD image sensor combined with the new DSP chip delivering a super high resolution of 540TVL. The dome range is available as colour or as Day & Night. The domes come with low voltage input, allowing either 12VDC or 24VAC. The dome camera is complete with a 2.8 - 12.0mm auto iris speed varifocal lens (ZC-D5212PHA) or 2.9 - 2.8mm auto iris varifocal lens (ZC-D5029PHA), providing optimum performance in demanding lighting conditions.

Further setup can be achieved by selecting the switches on the camera body. These include backlight compensation, AGC on/off, auto white balance / auto white tracking (colour only). The camera has a 3 axis gimble for adjusting the camera position, allowing the camera to be ceiling mounted or wall mounted.

#### Ordering Information

**ZC-D5550PHA** Super High Resolution Colour Dome

**ZC-D5212PHA** Super High Resolution Colour Dome

**ZC-D5029PHA** Super High Resolution Colour Dome

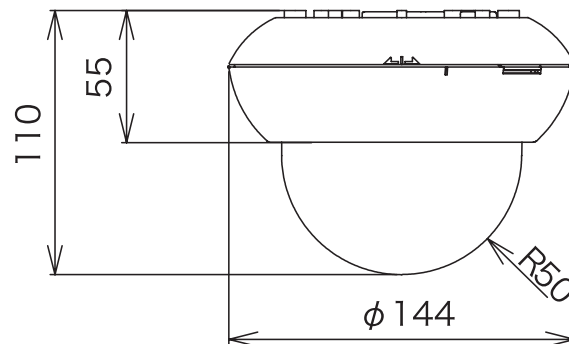
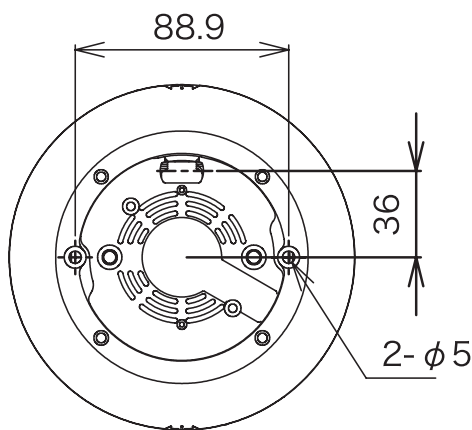

## ZC-D5000 Series

### Super High Resolution Colour & Colour/Mono Domes

#### Comparison of Monitoring Images

Object distance Model NO.	2m	5m	10m	20m
ZC-D5029PHA				
ZC-D5212PHA				
ZC-D5550PHA				

#### Technical Specification

Model	ZC-D5029PHA Digital Day / Night	ZC-D5212PHA Digital Day / Night	ZC-D5550PHA Digital Day / Night
	Super High Resolution		
Focal Length	2.9mm - 8.2mm	2.8mm - 12mm	5.0mm - 50mm
Max. Aperture Ratio	1:1.0	1:1.3	1:1.3
Iris	F1.0 - F360C (DC auto iris)	F1.3 - F360 (DC auto iris)	F1.3 - F360C (DC auto iris)
Angle of View (Wide to Tele)	D 133.9° ~ 44.2° H 98.3° ~ 35.2° V 70.7° ~ 26.3°	121.8° ~ 29.6° 98.2° ~ 23.8° 73.6° ~ 17.8°	64.0° ~ 6.9° 51.8° ~ 5.6° 39.2° ~ 4.3°
TV System	PAL		
Scanning System	2:1 Interlace		
Image Sensor	1/3 type Interline transfer CCD		
Effective Elements	752(H) x 582(V)		
Scanning Frequency	15.625kHz / 50Hz (V)		
Video Output	1.0V (p-p) / 75Ω		
Horizontal Resolution	More than 540 TVL		
Minimum Illumination	50IRE 0.85 lx (D D/N: OFF) / 0.57 lx (D D/N: ON) 30IRE 0.44 lx (D D/N: OFF) / 0.29 lx (D D/N: ON) With IR Illuminance -	1.41 lx (D D/N: OFF) / 0.94 lx (D D/N: ON) 0.73 lx (D D/N: OFF) / 0.47 lx (D D/N: ON)	
S/N Ratio	More than 50dB (At minimum AGC gain)		
Gamma Characteristic	0.45		
Sync. System	Internal synchronization (INT.) / Line Lock (L.L.): For 50Hz regions only		
Electronic Shutter	1/50 sec. fixed (Flickerless: OFF), 1/120 sec. fixed (Flickerless: ON)		
White Balance	DC iris / AES (only when lens focus adjustment is used)		
Power Supply	DC12V	ATW	
Power Consumption	AC24V	AC24V ±10% 50Hz/60Hz ±1Hz, DC12V ±10% 3.0W	
Ambient Temperature	Operational limits: -10°C ~ +50°C / Storage limits: -20°C ~ +60°C		
Ambient Humidity (No condensing)	Operational limit: Maximum 85% RH / Storage limit: Maximum 95% RH		
External dimensions	144(Ø)mm x 110(H)mm		
Weight (approx.)	445g	460g	530g
Adjustable Volume	DC iris adjustment, AC line lock phase adjustment volume		
Accessories	Cable for service monitor, Adapter ring, Self-tapping screws (M4 x 20: 2pcs), Template, Instruction manual (this document)		

## ZC-D7000 Series

Super High Resolution Day / Night Domes



The GANZ® ZC-D7000 Series dome offer full-featured performance at an economical price. Integrated varifocal lens for versatile application and easy installation. Digital or True Day / Night models.

### Key Features

- 540 TVL Super High Resolution with built-in 1/3-type CCD
- 3.3 - 12mm **computar®** integrated varifocal lens
- 3-axis manual pan / tilt rotation bracket
- Digital or True Day / Night models
- Wide Dynamic Range function
- Easy installation on wall or ceiling
- 230VAC / 12VDC - 24VAC autosense
- Includes BNC video cable and power lead
- UL listed

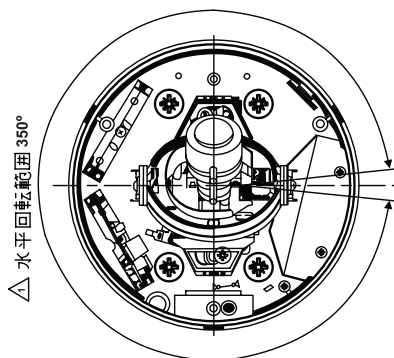
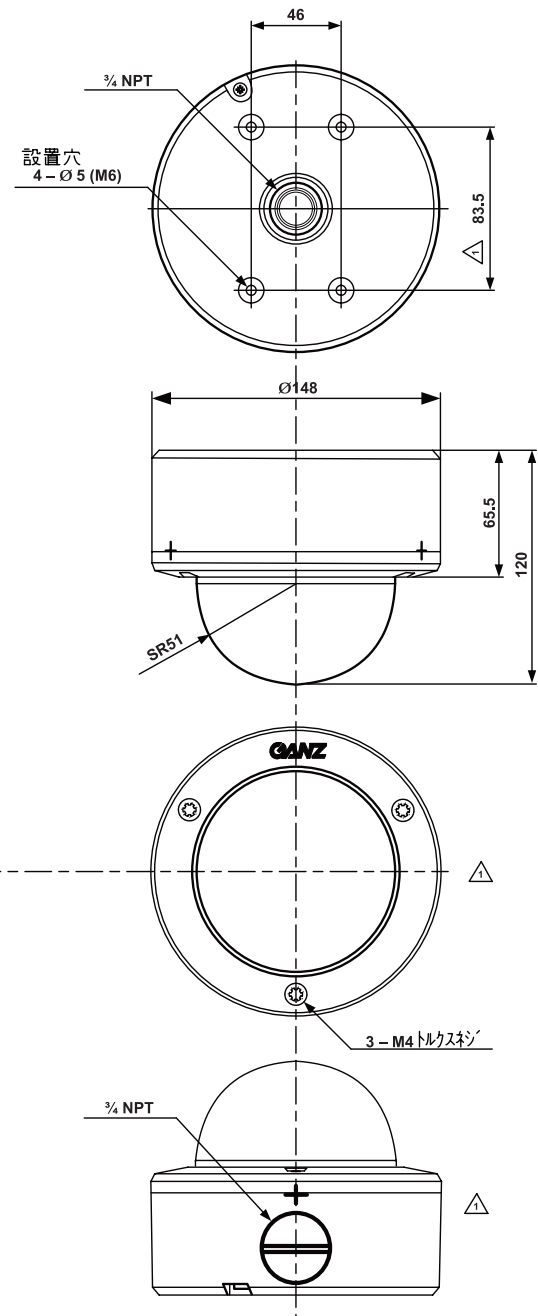

## ZC-D7000 Series

### Super High Resolution Day / Night Domes

#### Technical Specification

Model		ZC-D7312PHA Digital Day / Night	ZC-DW7312PHA WDR Digital Day / Night	ZC-DWN7312PHA WDR Mechanical Day / Night	ZC-DWNT7312PHE WDR Mechanical Day / Night Vandal-Proof
Focal Length		3.3mm - 12mm			
Max. Aperture Ratio		1:1.4			
Iris		F1.4 - F360 (DC auto iris)			
Angle of View (Wide to Tele)	D	125.7° ~ 29.9°			
	H	89.8° ~ 23.9°			
	V	63.6° ~ 17.9°			
TV System		PAL			
Scanning System		2:1 Interlace			
Image Sensor		1/3 type Image Format vertical double density Interline transfer CCD			
Effective Elements		752(H) x 582(V)			
Scanning Frequency		15.625kHz / 50Hz (V)			
Video Output		1.0V (p-p) / 75Ω			
Horizontal Resolution		More than 540 TVL			
Minimum Illumination					
F1.4 (50IRE)	SENS UP: OFF	1.14 1x (Night mode, B/W)		0.12 1x (Night mode, B/W)	
	SENS UP: ON	0.18 1x (Night mode, B/W)		0.019 1x (Night mode, B/W)	
F1.4 (30IRE)	SENS UP: OFF	0.57 1x (Night mode, B/W)		0.06 1x (Night mode, B/W)	
	SENS UP: ON	0.09 1x (Night mode, B/W)		0.01 1x (Night mode, B/W)	
S/N Ratio		More than 50dB (At minimum AGC gain)			
Gamma Characteristic		0.45			
Sync. System		Internal synchronization (INT.) / Line Lock (L.L.)			
Electronic Shutter		1/50 sec. fixed (Flickerless: OFF), 1/120 sec. fixed (Flickerless: ON)			
Iris Control		DC iris / AES (only when lens focus adjustment is used)			
Wide Dynamic Range		ON: Dynamic range 54dB / OFF			
White Balance		ATW		ATW / AWB	
Ss (Slow Shutter: SENS UP)		ON: Auto (Up to x8) / OFF			
Day / Night Control		ON / OFF			
Digital Noise Reduction		ON / OFF			
Backlight Compensation (BLC)		ON / OFF			
Water and Dust Resistance		IP66			
Materials		1) Housing: Aluminium die cast 2) Dome cover: Polycarbonate			
Power Supply		12VDC - 24VAC	12VDC - 24VAC	12VDC - 24VAC	230VAC
Power Consumption		6W or less			
Ambient Temperature		Operational limits: -10°C ~ + 50°C / Storage limits: -20°C ~ + 60°C			
Ambient Humidity (No condensing)		Operational limit: Maximum 85% RH / Storage limit: Maximum 95% RH			
External dimensions		150(∅)mm x 120(H)mm			
Weight (approx.)		1.2 kg			
Adjustable Volume		1) Wide Dynamic Range level adjustment volume 2) DC iris level adjustment volume 3) AC line lock phase adjustment volume			



THRU Vision Series Zoom Lens

H60Z1238A-IRF

Key Features

- 25 - 1500mm (with 2x extender)
- F3.8 - F3000
- Video Auto Iris
- 1/2" Format, C-Mount
- IR Corrected for True Day / Night
- On / Off Fog Through Filter Function



Model		H60Z1238A-IRF					
Focal Length		12.5mm - 750mm	Effective Lens	Front	Ø98.8mm		
		25mm - 1500mm (with 2x extender.)	Aperture	Rear	Ø13.6mm		
			Back Focal Length		53.23mm		
Max. Aperture Ratio		1:3.8	Flange Back Length		17.526mm		
Max. Image Format		6.4mm x 4.8mm (Ø8mm)	Mount		C-Mount		
Operation Range	Iris	F3.8 - F3000	Filter Size		M107 P = 1mm		
	Focus	5m - Inf.	Tripod Screw		2 x 1/4-20 UNC		
	Zoom	12.5mm - 1500mm	Dimensions		W154mm x H137mm x D354mm		
Control	Iris	Video Auto Iris, Over-ride Manual	Weight		5200g		
	Focus	Motorized					
	Zoom	Motorized					
Object Dimension at M.O.D.	12.5mm	246.5cm x 184.9cm	25mm		123.3cm x 92.4cm		
	750mm	4.1cm x 3.1cm	1500mm		2.1cm x 1.5cm		
Angle of View (w/o Extender)	D	1/2 type	35.5° - 0.62°	1/3 type	26.1° - 0.47°	1/4 type	20.4° - 0.35°
	H		28.7° - 0.48°		21.7° - 0.37°		16.4° - 0.28°
	V		21.7° - 0.37°		16.4° - 0.28°		12.3° - 0.20°
Supply Voltage		DC 12V (9-15)V	Focus		Zoom		
Current		50mA or less	DC6/12V switchable		DC6/12V switchable		
Response Time		0.5 sec.	90mA or less		90mA or less		
Preset Potentiometer		-	Approx. 6 sec.		Approx. 5 sec.		
Light Weighting method		Adjustable between Average - Peak (to be set at Average at Factory)					
Input Signal		Video Signal (V. or V.S.)					
Iris Accuracy		±3.5% at A.P.L 0.5V					
Sensitivity Adjustment		0.5V (p-p) - 0.9V (p-p) (Video Signal)					
Input Impedance		High Impedance 100kΩ					
Operating Temperature		-10°C - +50°C					

Specifications are subject to change without notice.

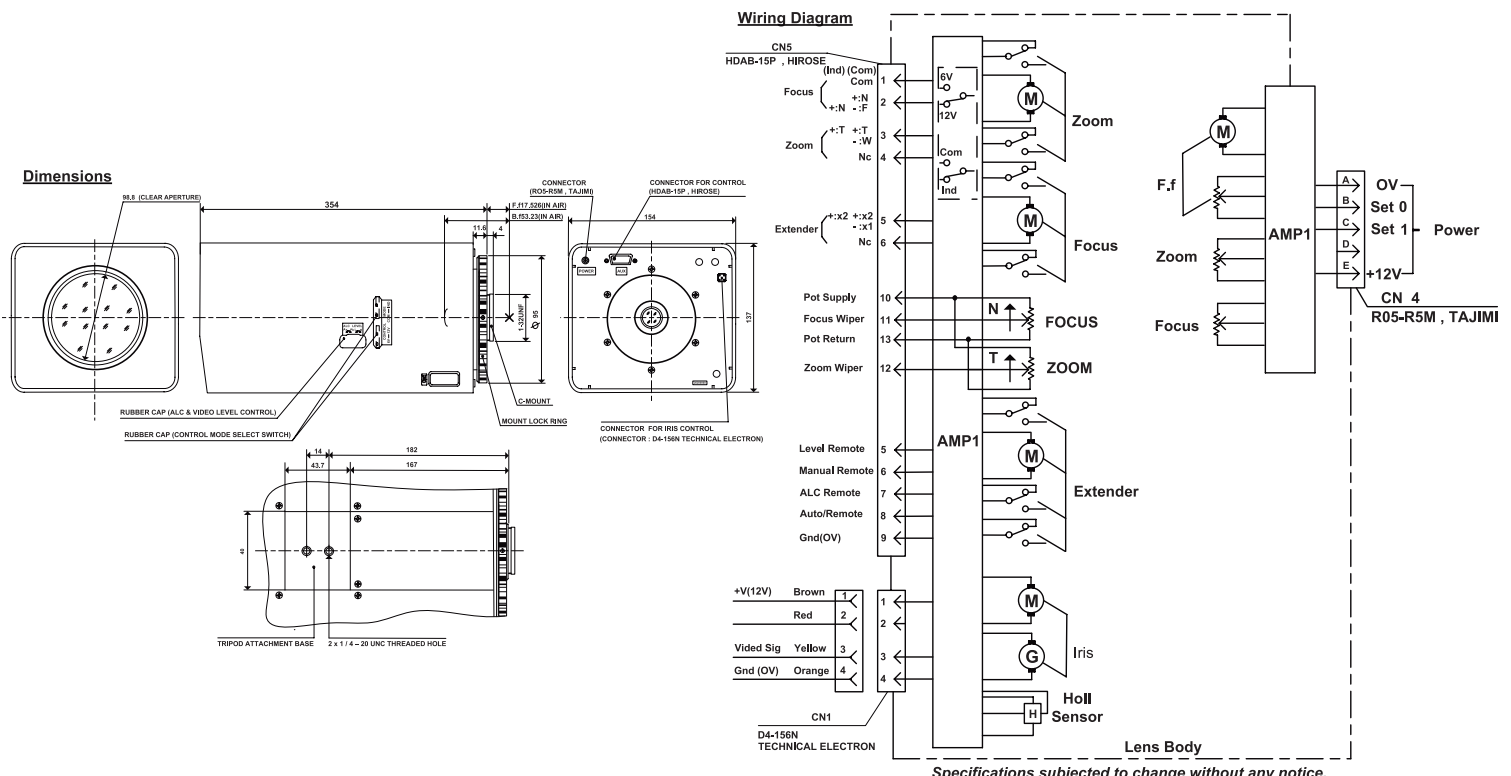

Specifications subjected to change without any notice.

THRU Vision Series Zoom Lens

H35Z2030AMSP

Key Features

- 35x 20mm - 700mm F3.0
- For 1/2 type Cameras, Motorized Zoom
- C-Mount, W/2.0x Extender



Model	H35Z2030AMSP		With Video Auto Iris and Preset				
Focal Length	20mm - 700mm		Effective Lens	Front	Ø80.1mm		
			Aperture	Rear	Ø10.0mm		
			Back Focal Length		8.26mm		
Max. Aperture Ratio	1:3.0		Flange Back Length		17.526mm		
Max. Image Format	6.4mm x 4.8mm (Ø8mm)		Mount		C-Mount		
Operation Range	Iris	F3.0 - F1000 (W/ND Filter)	Filter Size		M86 P = 1.0mm		
	Focus	3m - Inf.	Tripod Screw		1/4 -20UNC		
	Zoom	20mm - 700mm	Dimensions		W97mm x H108mm x D249.5mm		
Control	Iris	Video Auto Iris,	Weight		2300g		
	Focus	Motorized					
	Zoom	Motorized					
Object Dimension at M.O.D.	10mm	89.0cm x 66.7cm					
	210mm	2.66cm x 2.00cm					
Angle of View (w/o Extender)	D	1/2 type	22.07° - 0.66°	1/3 type	16.59° - 0.50°	1/4 type	12.44° - 0.38°
	H		17.66° - 0.53°		13.24° - 0.40°		9.93° - 0.30°
	V		13.24° - 0.40°		10.00° - 0.30°		7.50° - 0.21°
Supply Voltage	DC6 - 12V		Focus		Zoom		
Current	40mA or less		DC6/12V		DC16/12V		
Response Time	4 - 8 sec.		40mA or less		40mA or less		
Preset Potentiometer	-		Approx. 7 sec. (when 10V input)		Approx. 7 sec. (when 10V input)		
Light Weighting method	Adjustable between Average - Peak (to be set at Average at Factory)		10kΩ VR		10kΩ VR		
Input Signal	Video Signal (V. or V.S.)						
Iris Accuracy	±15% at Video Signal Level						
Sensitivity Adjustment	0.4V (p-p) - 1.0V (p-p) (Video Signal)						
Input Impedance	High Impedance						
Operating Temperature	-10°C - +50°C						

Specifications are subject to change without notice.

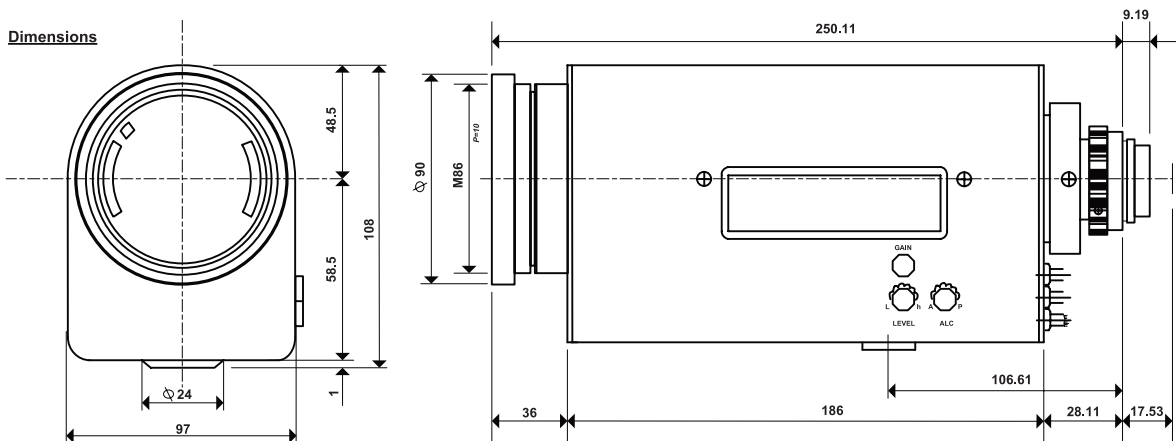

Wiring Diagram

Iris, Focus & Zoom

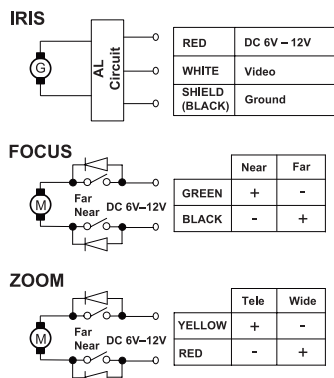

Potentiometer

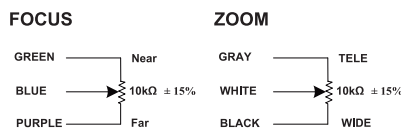

Specifications subjected to change without any notice.

## THRU Vision Series Zoom Lens

# H30Z1015AMSPR

### Key Features

- 30x 10mm - 300mm F1.5
- For 1/2 type Cameras, Motorized Zoom
- C-Mount



Model	H30Z1015AMSPR		With Video Auto Iris Over-ride Manual and Preset				
Focal Length	10mm - 300mm		Effective Lens	Front	Ø94mm		
			Aperture	Rear	Ø14.8mm		
			Back Focal Length		15.8mm		
Max. Aperture Ratio	1:1.5		Flange Back Length		17.526mm		
Max. Image Format	6.4mm x 4.8mm (Ø8mm)		Mount		C-Mount		
Operation Range	Iris	F1.5 - F560C	Filter Size		M100 P = 1mm		
	Focus	2.2m - Inf.	Tripod Screw		1/4 -20UNC		
	Zoom	10mm - 300mm	Dimensions		W125mm x H144.5mm x D246.5mm		
Control	Iris	Video Auto Iris / Over-ride Manual	Weight		3225g		
	Focus	Motorized					
	Zoom	Motorized					
Object Dimension at M.O.D.	10mm	140.8cm x 104.8cm					
	300mm	4.8cm x 3.6cm					
Angle of View (w/o Extender)	D	1/2 type	44.0° - 1.55°	1/3 type	33.3° - 1.17°	1/4 type	25.1° - 0.88°
	H		35.5° - 1.25°		26.8° - 0.94°		20.1° - 0.71°
	V		26.8° - 0.94°		20.1° - 0.71°		15.1° - 0.53°
Supply Voltage	DC8.5V - DC16V		Focus	Zoom			
Current	50mA or less		DC8V	DC8V			
Response Time	Approx. 2 sec.		80mA or less	60mA or less			
Preset Potentiometer	-		Approx. 8.5 sec.	Approx. 4.5 sec.			
Light Weighting method	-		5kΩ VR	5kΩ VR			
Remote Control	Adjustable between Average - Peak (to be set at Average at Factory)						
Input Signal	ALC Remote (Option) / Over-ride Manual						
Iris Accuracy	±15% at Video Signal Level						
Sensitivity Adjustment	0.5V (p-p) - 1.0V (p-p) (Video Signal)						
Input Impedance	High Impedance						
Operating Temperature	-10°C - +50°C						

Specifications are subject to change without notice.

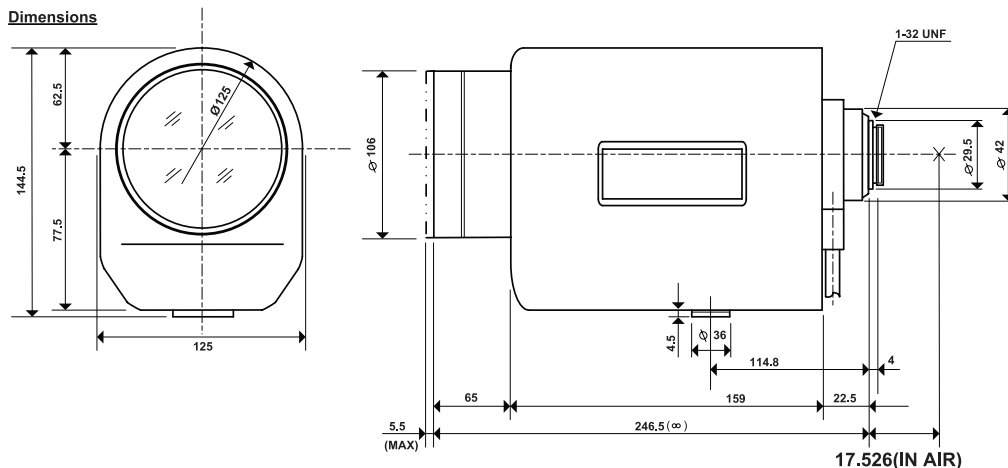

### Wiring Diagram

#### PRESET POTENTIOMETER

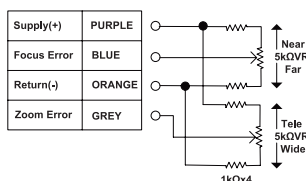

Specifications subjected to change without any notice.

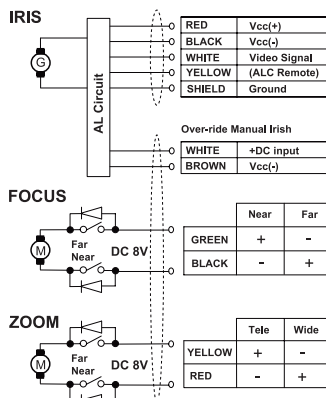

#### (ALC Remote)

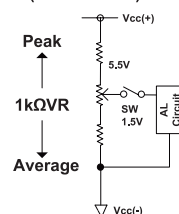

#### Over-ride Manual

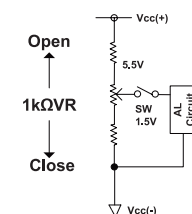

Vcc represent Input Voltage  
The Remote Voltage should be set between 1.5 - 5.5V, and Level Remote should be OFF.

## THRU Vision Series Zoom Lens

# T34Z5518AMSR-CS

### Key Features

- 34x 5.5mm - 187mm F1.8
- For 1/3 type Cameras, Motorized Zoom
- CS-Mount



Model	T34Z5518AMSR-CS		With Video Auto Iris Over-ride Manual and Preset	
Focal Length	5.5mm - 187mm		Effective Lens Front	Ø70.0mm
			Aperture Rear	Ø9.1mm
			Back Focal Length	12.7mm
Max. Aperture Ratio	1:1.8			
Max. Image Format	4.8mm x 3.6mm (Ø6mm)		Flange Back Length	12.5mm
Operation Range	Iris	F1.8 - F560C	Mount	CS-Mount
	Focus	1.5m - Inf.	Filter Size	M77 P = 0.75mm
	Zoom	5.5mm - 187mm	Tripod Screw	1/4 -20UNC
Control	Iris	Video Auto Iris / Over-ride Manual	Dimensions	W82mm x H97.4mm x D160mm
	Focus	Motorized, Preset	Weight	1180g
	Zoom	Motorized, Preset		
Object Dimension at M.O.D.	5.5mm	129.2cm x 95.2cm		
	187mm	4.1cm x 3.1cm		
Angle of View (w/o Extender)	D	1/3 type 57.5° - 1.92°	1/4 type 43.8° - 1.45°	
	H	46.6° - 1.55°	35.2° - 1.17°	
	V	35.2° - 1.17°	26.5° - 0.88°	
Supply Voltage	DC8.5V - DC16V		Focus	DC8V
Current	50mA or less		Zoom	DC8V
Response Time	Approx. 2 sec.			
Preset Potentiometer	-			
Light Weighting method	Adjustable between Average - Peak (to be set at Average at Factory)			
Remote Control	Level Remote (Option) / Over-ride Manual			
Input Signal	Video Signal (V. or V.S.)			
Iris Accuracy	±15% at Video Signal Level			
Sensitivity Adjustment	0.5V (p-p) - 1.0V (p-p) (Video Signal)			
Input Impedance	High Impedance			
Operating Temperature	-10°C - +50°C			

Specifications are subject to change without notice.

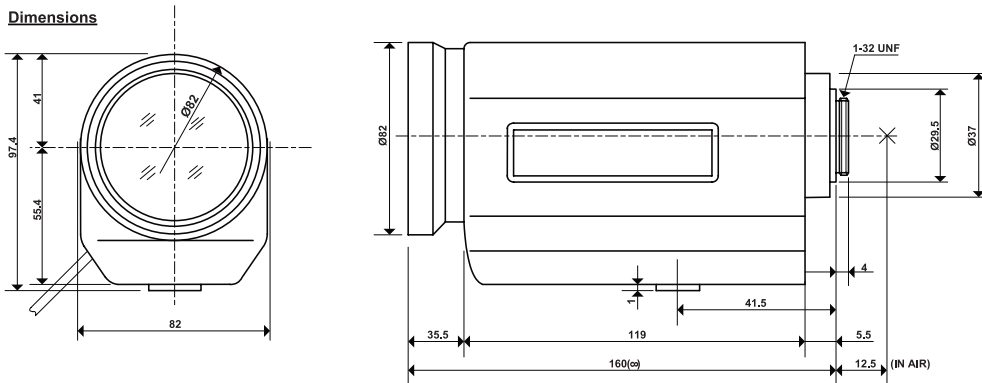

### Wiring Diagram

#### PRESET POTENTIOMETER

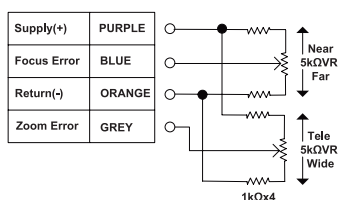

Specifications subjected to change without any notice.

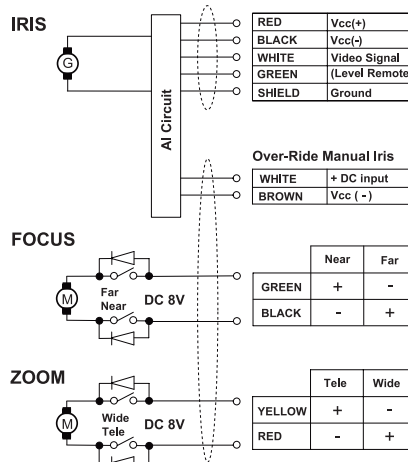

#### (Level Remote)

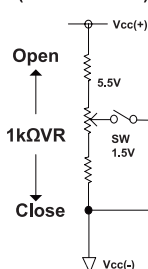

#### Over-ride Manual

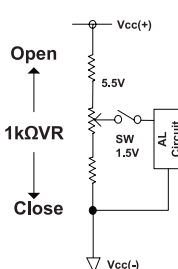

Vcc represent Input Voltage  
The Remote Voltage should be set between 1.5 - 5.5V, and Level Remote should be OFF.

# THRU Vision Series Zoom Lens

## T34Z5518AMSPR-CS

### Key Features

- 34x 5.5mm - 187mm F1.8
- For 1/3 type Cameras, Motorized Zoom
- CS-Mount



Model		T34Z5518AMSPR-CS		With Video Auto Iris and Over-ride Manual	
Focal Length	5.5mm - 187mm		Effective Lens	Front	Ø70.0mm
			Aperture	Rear	Ø9.1mm
			Back Focal Length		12.7mm
Max. Aperture Ratio	1:1.8		Flange Back Length	12.5mm	
Max. Image Format	4.8mm x 3.6mm (Ø6mm)		Mount	CS-Mount	
Operation Range	Iris	F1.8 - F560C	Filter Size	M77 P = 0.75mm	
	Focus	1.5m - Inf.	Tripod Screw	1/4 -20UNC	
	Zoom	5.5mm - 187mm	Dimensions	W82mm x H97.4mm x D160mm	
Control	Iris	Video Auto Iris / Over-ride Manual	Weight	1150g	
	Focus	Motorized			
	Zoom	Motorized			
Object Dimension at M.O.D.	5.5mm	129.2cm x 95.2cm			
	187mm	4.1cm x 3.1cm			
Angle of View (w/o Extender)	D	1/3 type	57.5° - 1.92°	1/4 type	43.8° - 1.45°
	H		46.6° - 1.55°		35.2° - 1.17°
	V		35.2° - 1.17°		26.5° - 0.88°
Supply Voltage	Iris	DC8.5V - DC16V	Focus	DC8V	Zoom
Current		50mA or less		40mA or less	DC8V
Response Time		Approx. 2 sec.		Approx. 3.5 sec.	Approx. 3.5 sec.
Preset Potentiometer		-		-	-
Light Weighting method	Adjustable between Average - Peak (to be set at Average at Factory)				
Remote Control	Level Remote (Option) / Over-ride Manual				
Input Signal	Video Signal (V. or V.S.)				
Iris Accuracy	±15% at Video Signal Level				
Sensitivity Adjustment	0.5V (p-p) - 1.0V (p-p) (Video Signal)				
Input Impedance	High Impedance				
Operating Temperature	-10°C - +50°C				

Specifications are subject to change without notice.

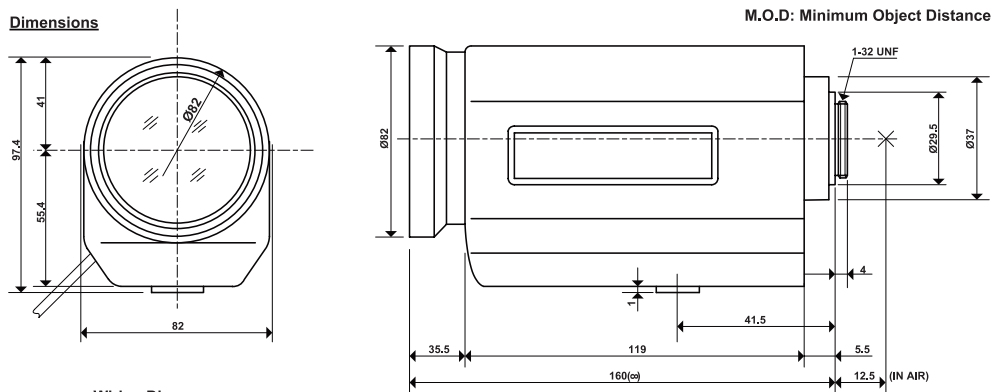

### Wiring Diagram

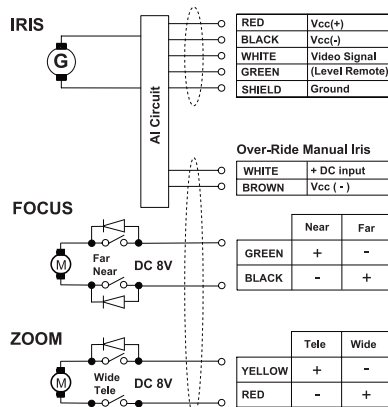

### (Level Remote)

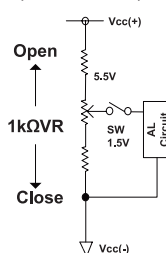

### Over-ride Manual

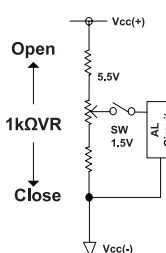

Vcc represent Input Voltage  
The Remote Voltage should be set between 1.2 - 5.2V, and Level Remote should be OFF.

Specifications subjected to change without any notice.



# THRU Vision Series Zoom Lens

## T34Z5518PDC-CS

### Key Features

- 34x 5.5mm - 187mm F1.8
- For 1/3 type Cameras, Motorized Zoom
- CS-Mount



Model		T34Z5518PDC-CS		With DC Auto Iris and Preset		
Focal Length	5.5mm - 187mm		Effective Lens	Front	Ø70.0mm	
			Aperture	Rear	Ø9.1mm	
			Back Focal Length		12.7mm	
Max. Aperture Ratio	1:1.8		Flange Back Length		12.5mm	
Max. Image Format	4.8mm x 3.6mm (Ø6mm)		Mount		CS-Mount	
Operation Range	Iris	F1.8 - F560C	Filter Size		M77 P = 0.75mm	
	Focus	1.5m - Inf.	Tripod Screw		1/4 -20UNC	
	Zoom	5.5mm - 187mm	Dimensions		W82mm x H97.4mm x D160mm	
Control	Iris	DC Auto Iris	Weight		1150g	
	Focus	Motorized, Preset				
	Zoom	Motorized, Preset				
Object Dimension at M.O.D.	5.5mm	129.2cm x 95.2cm				
	187mm	4.1cm x 3.1cm				
Angle of View (w/o Extender)	D	1/3 type	57.5° - 1.92°	1/4 type	43.8° - 1.45°	
	H		46.6° - 1.55°		35.2° - 1.17°	
	V		35.2° - 1.17°		26.5° - 0.88°	
Supply Voltage	Iris	-	Focus	DC8V	Zoom	DC8V
Current		-		40mA or less		25mA or less
Response Time		-		Approx. 3.5 sec.		Approx. 3.5 sec.
Preset Potentiometer		-		5kΩ VR		5kΩ VR
Coil	Drive	190Ω				
	Control	1000Ω				
Operating Temperature	-10°c - +50°c					

Specifications are subject to change without notice.

### Dimensions

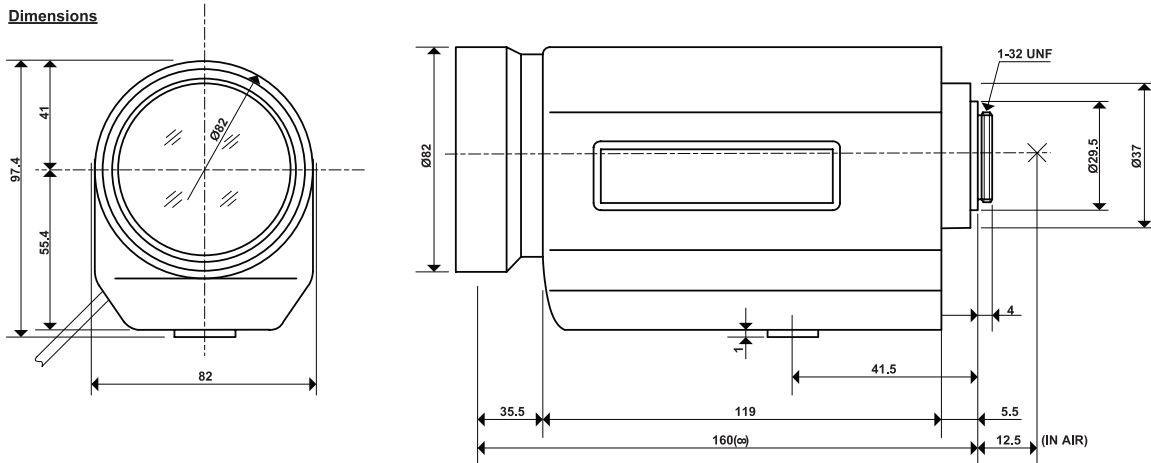

### Wiring Diagram

#### PRESET POTENTIOMETER

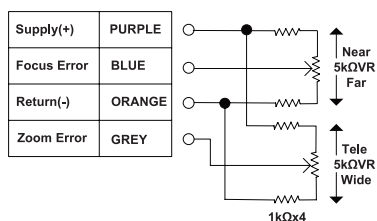

#### IRIS



#### Pin No.

1	BROWN	Control(-)
2	RED	Control(+)
3	YELLOW	Drive(+)
4	ORANGE	Drive(-)

#### FOCUS

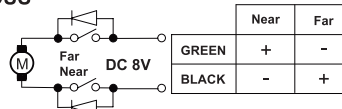

#### ZOOM

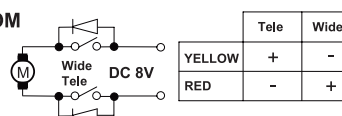

Specifications subjected to change without any notice.

# THRU Vision Series Zoom Lens

## T34Z5518DC-CS

### Key Features

- 34x 5.5mm - 187mm F1.8
- For 1/3 type Cameras, Motorized Zoom
- CS-Mount



Model		T34Z5518DC-CS		With DC Auto Iris		
Focal Length	5.5mm - 187mm		Effective Lens	Front	Ø70.0mm	
			Aperture	Rear	Ø9.1mm	
			Back Focal Length		12.7mm	
Max. Aperture Ratio	1:1.8		Flange Back Length		12.5mm	
Max. Image Format	4.8mm x 3.6mm (Ø6mm)		Mount		CS-Mount	
Operation Range	Iris	F1.8 - F560C	Filter Size		M77 P = 0.75mm	
	Focus	1.5m - Inf.	Tripod Screw		1/4 -20UNC	
	Zoom	5.5mm - 187mm	Dimensions		W82mm x H97.4mm x D160mm	
Control	Iris	DC Auto Iris	Weight		1110g	
	Focus	Motorized				
	Zoom	Motorized				
Object Dimension at M.O.D.	5.5mm	129.2cm x 95.2cm				
	187mm	4.1cm x 3.1cm				
Angle of View (w/o Extender)	D	1/3 type	57.5° - 1.92°	1/4 type	43.8° - 1.45°	
	H		46.6° - 1.55°		35.2° - 1.17°	
	V		35.2° - 1.17°		26.5° - 0.88°	
Supply Voltage	Iris	-	Focus	DC8V	Zoom	DC8V
Current		-		40mA or less		25mA or less
Response Time		-		Approx. 3.5 sec.		Approx. 3.5 sec.
Preset Potentiometer		-		-		-
Coil	Drive	190Ω				
	Control	1000Ω				
Operating Temperature	-10°c - +50°c					

Specifications are subject to change without notice.

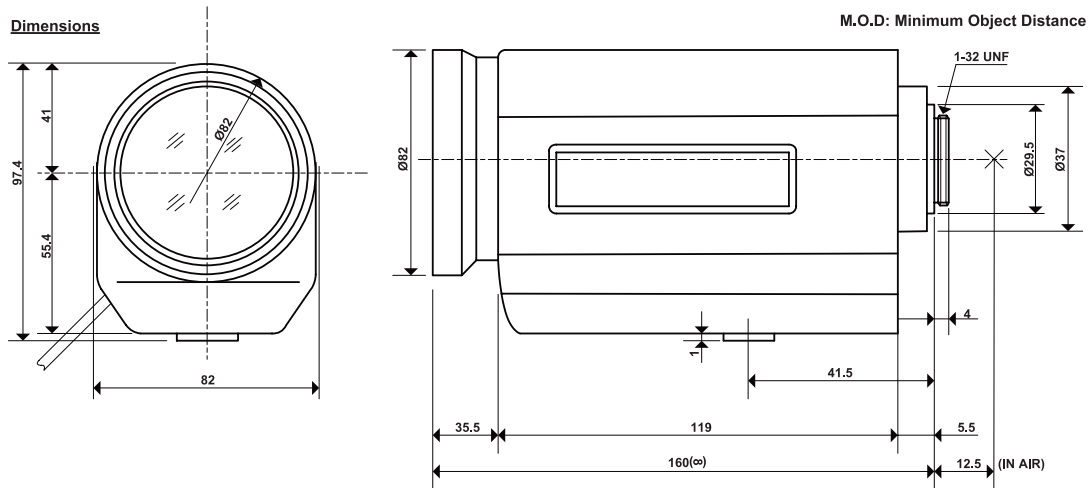

### Wiring Diagram

#### IRIS



#### Pin No.

1	BROWN	Control(-)
2	RED	Control(+)
3	YELLOW	Drive(+)
4	ORANGE	Drive(-)

#### FOCUS

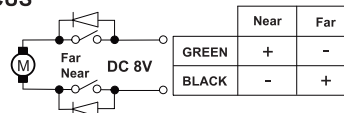

#### ZOOM

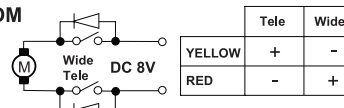

Specifications subjected to change without any notice.

# THRU Vision Series Zoom Lens

## T21Z5816AMSP-CS2

### Key Features

- 21x 5.8mm - 121.8mm F1.6
- For 1/3 type Cameras, Motorized Zoom
- CS-Mount



Model		T21Z5816AMSP-CS2		With Video Auto Iris and Preset	
Focal Length	5.8mm - 121.8mm		Effective Lens	Front	Ø53.2mm
			Aperture	Rear	Ø10.6mm
			Back Focal Length		13.6mm
Max. Aperture Ratio	1:1.6		Flange Back Length		12.5mm
Max. Image Format	4.8mm x 3.6mm (Ø6mm)		Mount		CS-Mount
Operation Range	Iris	F1.6 - F560C	Filter Size		M62 P = 0.75mm
	Focus	1.5m - Inf.	Tripod Screw		1/4 -20UNC
	Zoom	5.8mm - 121.8mm	Dimensions		W70mm x H81mm x D126.5mm
Control	Iris	Video Auto Iris	Weight		740g
	Focus	Motorized, Preset			
	Zoom	Motorized, Preset			
Object Dimension at M.O.D.	5.5mm	123.7cm x 91.1cm			
	187mm	6cm x 4.7cm			
Angle of View (w/o Extender)	D	1/3 type	55.5° - 2.9°	1/4 type	42.0° - 2.2°
	H		44.8° - 2.3°		33.8° - 1.8°
	V		33.8° - 1.8°		25.3° - 1.3°
Supply Voltage	DC8.5V - DC16V		Focus	Zoom	
Current	40mA or less		DC8V	DC8V	
Response Time	Approx. 2 sec.		40mA or less	35mA or less	
Preset Potentiometer	-		Approx. 4.5 sec.	Approx. 3.5 sec.	
Light Weighting method	Adjustable between Average - Peak (to be set at Average at Factory)		5kΩ VR	5kΩ VR	
Remote Control	Level Remote (Option) / ALC Remote (Option)				
Input Signal	Video Signal (V. or V.S.)				
Iris Accuracy	±15% at Video Signal Level				
Sensitivity Adjustment	0.5V (p-p) - 1.0V (p-p) (Video Signal)				
Input Impedance	High Impedance				
Operating Temperature	-10°C - +50°C				

Specifications are subject to change without notice.

### Dimensions

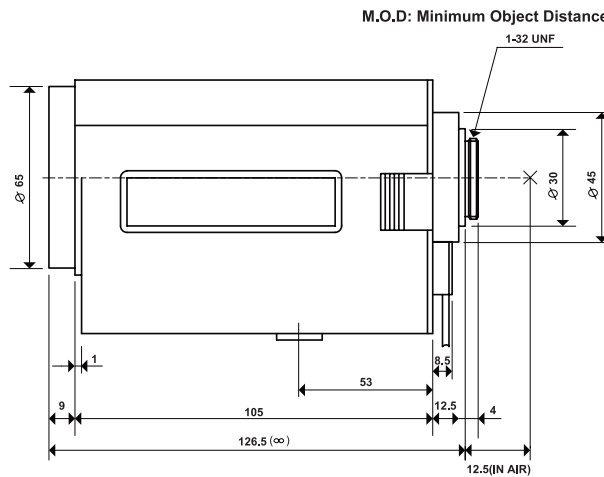
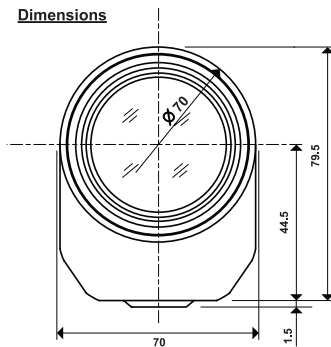

### Wiring Diagram

#### PRESET POTENTIOMETER

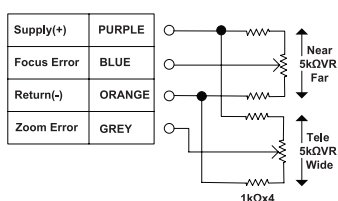

#### IRIS

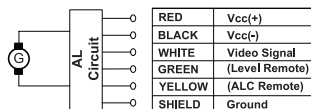

#### FOCUS

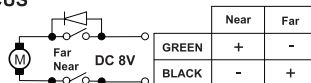

#### ZOOM

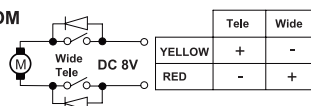

#### (Level Remote)

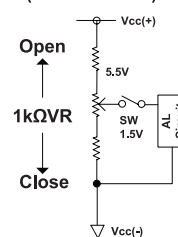

#### (ALC Remote)

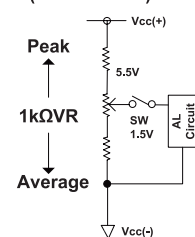

Specifications subjected to change without any notice.

## THRU Vision Series Zoom Lens

# T21Z5816PDC-CS

### Key Features

- 21x 5.8mm - 121.8mm F1.6
- For 1/3 type Cameras, Motorized Zoom
- CS-Mount



Model		T21Z5816PDC-CS		With DC Auto Iris	
Focal Length		5.8mm - 121.8mm		Effective Lens	Front
				Aperture	Rear
				Back Focal Length	Ø53.2mm
Max. Aperture Ratio		1:1.6		Ø10.6mm	
Max. Image Format		4.8mm x 3.6mm (Ø6mm)		13.6mm	
Operation Range		Iris	F1.6 - F560C	Flange Back Length	12.5mm
		Focus	1.5m - Inf.	Mount	CS-Mount
		Zoom	5.8mm - 121.8mm	Filter Size	M62 P = 0.75mm
Control		Iris	DC Auto Iris	Tripod Screw	1/4 -20UNC
		Focus	Motorized, Preset	Dimensions	W70mm x H81mm x D126.5mm
		Zoom	Motorized, Preset	Weight	690g
Object Dimension at M.O.D.		5.8mm	123.7cm x 91.1cm		
		121.8mm	6cm x 4.7cm		
Angle of View (w/o Extender)		D	1/3 type 55.5° - 2.9°	1/4 type	42.0° - 2.2°
		H	44.8° - 2.3°		33.8° - 1.8°
		V	33.8° - 1.8°		25.3° - 1.3°
Supply Voltage		Iris	-	Focus	DC8V
Current				Zoom	DC8V
Response Time					40mA or less
Preset Potentiometer					35mA or less
Coil		Drive	190Ω		Approx. 4.5 sec.
		Control	1000Ω		Approx. 3.5 sec.
Operating Temperature			-10°C - +50°C		5kΩ VR

Specifications are subject to change without notice.

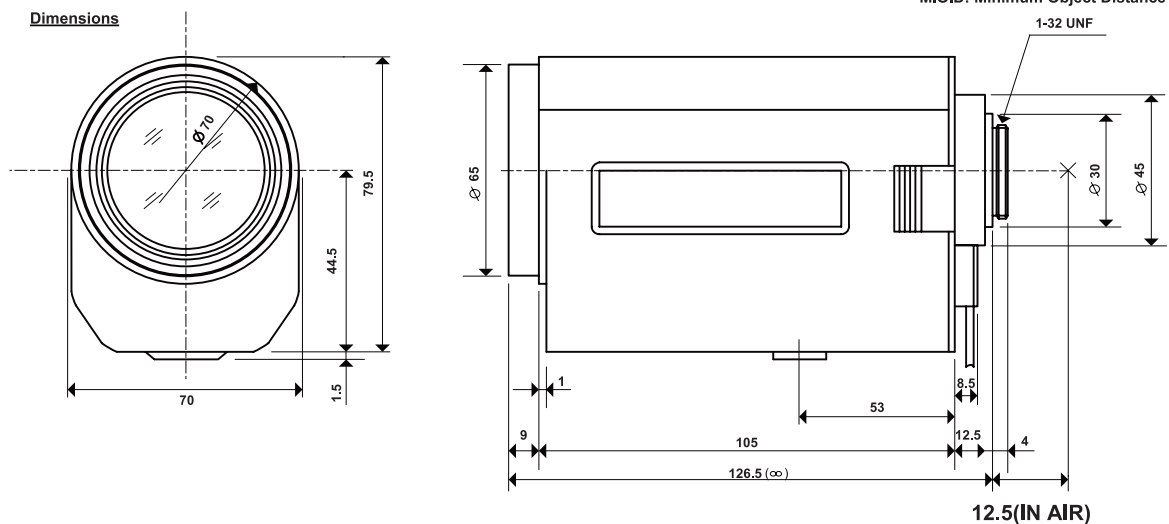

### Wiring Diagram

#### PRESET POTENTIOMETER

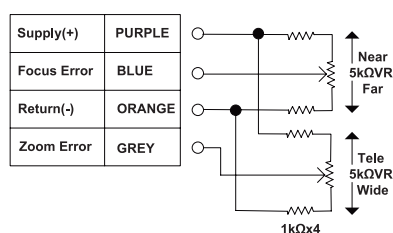

Specifications subjected to change without any notice.

#### IRIS



#### Pin No.

BROWN	Control(-)
RED	Control(+)
YELLOW	Drive(+)
ORANGE	Drive(-)

#### FOCUS

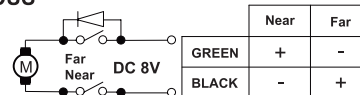

#### ZOOM

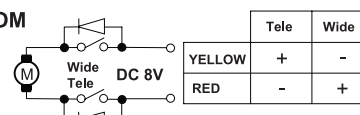

## MECHANISM AND ADVANTAGEOUS EFFECT OF IR LENS

### Non IR Lens

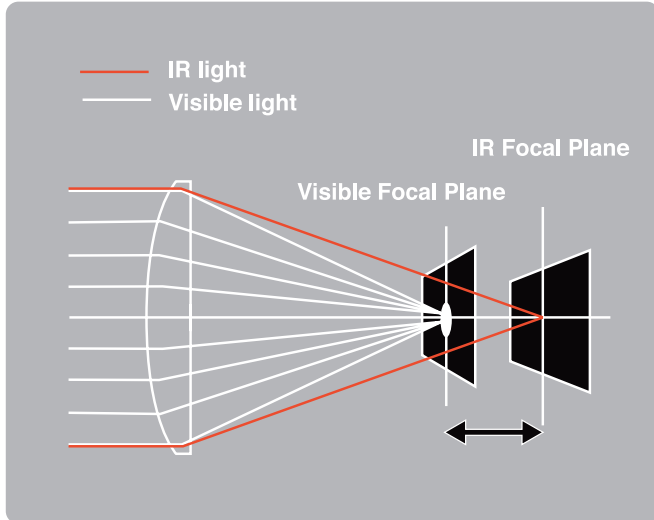

Day & Night cameras normally operate in the near-infrared / infrared zones at night, making the image "out of focus" and unsuitable if used with a conventional lens. "Computar" has developed new IR Lenses that utilize a special optical glass material which minimizes light dispersion. As a result, refocusing is not required when used with infrared lighting.

### IR Lens

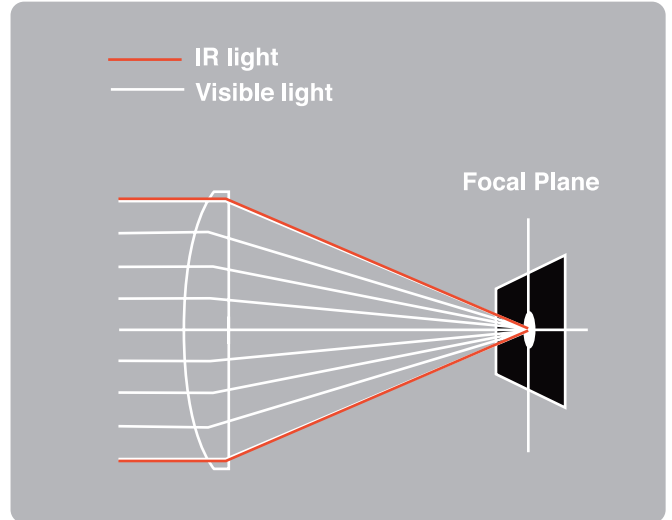

The lens is manufactured with a special ED glass (Extra dispersion) which does not widely disperse light of different wavelengths and with "special coating". This combination allows the lens to deliver perfect focus under normal lighting and also under IR illumination by transmitting more light to the infrared region.

Daytime



Night time

IR Lens



Non IR Lens



※ Monitoring Images with Day & Night cameras





CBC Co.,Ltd.

To our Customers:

CBC is one of the world leading manufacturers of CCTV products. Our ongoing challenge is to remain forefront on supply to commercial, industrial and domestic market. CBC focuses on reliability, competitiveness, speedy delivery & support of comprehensive range of products.

CBC design focus on 3 main criteria:

- High standards of performance
- Quality of products
- Compatibility with other systems

We are extremely motivated and dedicated to ensuring our customers comes first by providing highest quality control with our products. All products listed in this catalogue are manufactured by CBC Japan.

We thank you for your interest in our product and the opportunity to support your requirement.

Sincerely,

Tetsuro Kimura  
Division Leader I & IT Div

Nobuyuki Ohta  
Managing Director of CBC.S Pte Ltd

## Asia

### CBC. S PTE LTD.

#### Singapore

15 Jalan Kilang Barat, #04-03

Frontech Centre, SINGAPORE 159357

Tel : +65 6275 1221

Fax : +65 6275 0766

enquiries@cbcs.com.sg



### Head Quarters

Electronic Technology Company Image & Information Technology Division

2-15-13, Tsukishima, Chuo-ku,

Tokyo 104-0052, Japan

Tel : +81 (0)3 3536 5094

Fax : +81 (0)3 3536 4771

<http://www.cbc.co.jp>

[www.cbc.co.jp](http://www.cbc.co.jp)  
[www.computar.jp](http://www.computar.jp)

Tokyo HQ Registered



Tokyo HQ Registered

