

Chemical Process Pump



Features & Benefits

The design feature allows the complete rotating element to be removed for servicing without disconnecting pipework. If a spacer coupling is fitted then motor does not have to be moved. On re-assembly of pump coupling re-alignment problems are completely eliminated.

Applications

- ▶ Chemical transfer
- ▶ Mineral processing
- ▶ Fire-fighting systems
- ▶ Water supply systems
- ▶ Warm water heating, chilled & cooling water systems

Operation Data

Pump Size	DN 32 up to 300 mm
Capacities	up to 450 l/s
Heads	up to 160 Meter
Speed	1450 - 2900 rpm
Motor Rating	up to 400 kW
Operating Temperature	up to 140°C*

* The material of pumps differ according to the type of pumped liquid, operating temperature and pressure.

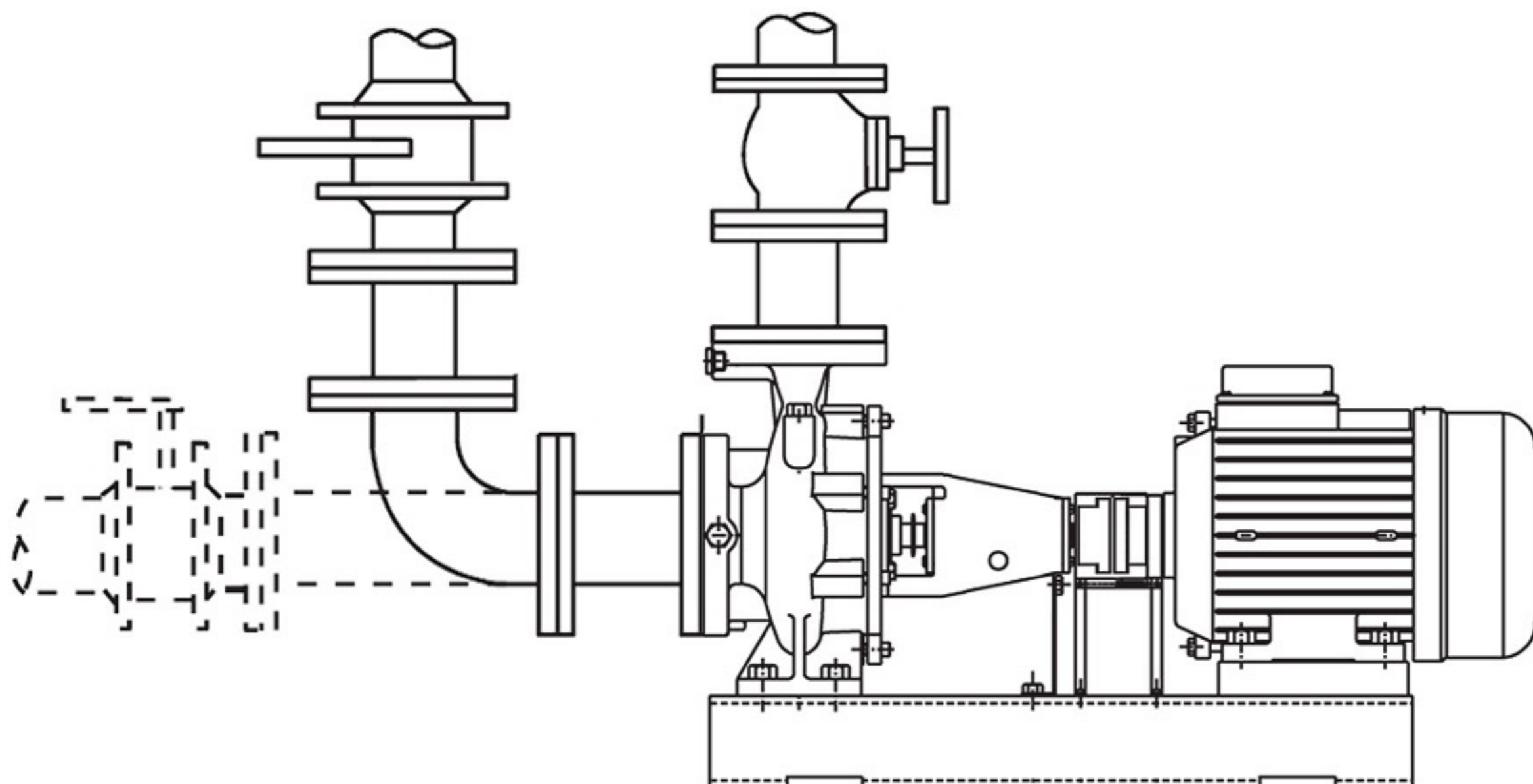

Performance Range

