

SLIDE CALIPERS

ELECTRONIC CALIPERS

798 ELECTRONIC CALIPERS

0-12"/0-300MM



The 798 Electronic Caliper features a large, easy-to-read, high contrast LCD readout. It includes IP67 protection against coolants, water, chips, dust and dirt often found in machine shop environments. Its induction type linear encoder system and Inch/millimeter conversion makes Starrett precision measuring tools the right choice for any job.

798 Electronic Calipers			
Range	Description	Cat. No.	EDP
0-6" (150mm)	Caliper with output	798B-6/150	12521
	Caliper with output	798B-6/150 W/SLC	12522
	Caliper with output	798BX-6/150	12782
	Caliper without output	798A-6/150	20798
0-8" (200mm)	Caliper with output	798B-8/200	12523
	Caliper with output	798B-8/200 W/SLC	12524
	Caliper without output	798A-8/200	20799
0-12" (300mm)	Caliper with output	798B-12/300	12525
	Caliper with output	798B-12/300 W/SLC	12526
	Caliper without output	798A-12/300	20800

Accessories, Cables and Case Information for 798 Electronic Calipers		
Description	Cat. No.	EDP
Center distance attachment	PT26151	64440
Depth attachment	PT22431	64640
Computer interface cable to PC (USB) with driver CD	PT63388	72517
Replacement non-contact computer interface cable to PC (USB)	PT63329-1	12733
Two 3-Volt batteries, CR2032	PT99492	65650
Deluxe padded case for 0-6" (150mm) calipers	723ZZ-6/722ZZ-6	57070
Finished wood case for 0-8" (200mm) calipers	950	63878
Finished wood case for 0-12" (300mm) calipers	946	56695

*Includes redemption card for Standard Letter of Certification (SLC).

FEATURES

- IP67 level of protection
- Fine adjustment
- Hardened stainless steel measuring surfaces
- Large, easy-to-read, high-contrast LCD digital readout
- Induction type linear encoder system
- RS232 output
- Heavy-duty bar and slide
- Slide lock
- One 3-volt battery for over one year of normal usage
- In/mm conversion
- Zero at any position
- Auto-Off after 30 minutes
- Reactivation of display with no loss of position
- Works well with Starrett DataSure® Wireless Data Collection Systems

Approximate Jaw Depths for 798 Electronic Calipers

	6" (150mm)	8" (200mm)	12" (300mm)
Outside	1-1/2" (38mm)	1-7/8" (47.6mm)	2-1/2" (63.5mm)
Inside	5/8" (16mm)	3/4" (19mm)	3/4" (19mm)



IP PROTECTION

An IP number is composed of two numbers, the first referring to protection against solid objects and the second against liquids.

First number 6: Totally protected against dust

Second number 7: Protection against submersion in water under standardized conditions of pressure for 30 minutes



ELECTRONIC CALIPERS

799 ELECTRONIC CALIPERS



0-40"/0-1000MM

The 799 Electronic Caliper is light, comfortable, easy-to-use, and constructed with features that have made Starrett slide calipers the machinist's first choice for many years.

The 799 offers a slim, streamlined profile, a large, clear, easy-to-read LCD display, long battery life, and function buttons for zero and inch/mm.

799 are available in 0-6", 0-8", and 0-12" sizes and the newly available extended range 24" and 40". All sizes furnished in a fitted, protective case.

FEATURES (ALL SIZES)

- Lightweight, ergonomic design
- Inch/millimeter conversion reads .0005" or 0.01mm
- Easy access to the single, long-life battery
- Last measuring position retained when shut off
- Hardened stainless steel body for long life
- Fine adjustment thumb wheel
- Lock screw to hold the slide in position
- Resolution is .0005" (0.01mm)
- Zero at any position

6", 8" AND 12" CALIPERS ONLY

- Large easy-to-read LCD, .32" high characters
- Automatic shut-off after 5 minutes of nonuse
- Linear accuracy meets DIN862
- Integrated depth rod

EXTENDED RANGE 24" AND 40" CALIPERS

- Preset and hold feature
- Minimum and maximum limits set
- I.D. jaw dimension is 0.800"/20.32mm
- LCD characters are .50" high
- Auto shut-off after 30 minutes of non-use

799 Electronic Calipers		
Range	Cat. No.	EDP
0-6" (150mm)	799A-6/150	67410
	799A-6/150 W/SLC†	67620
0-8" (200mm)	799A-8/200	67412
	799A-8/200 W/SLC†	67413
0-12" (300mm)	799A-12/300	67621
0-24" (600mm)	799AZ-24/600	11978
0-40" (1000mm)	799AZ-40/1000	11979

Accessories and Case Information for 799 Electronic Calipers		
Description	Cat. No.	EDP
Center distance attachment*	PT26151	64440
Depth attachment for 6", 9" and 150mm calipers	PT22431	64640
3 Volt battery, CR2032	PT99492	65650
Deluxe padded case for 0-6" (150mm) calipers	723ZZ-6/722ZZ-6	57070
Finished wood case for 0-8" (200mm) calipers	950	63878
Finished wood case for 0-12" (300mm) calipers	946	56695

* See details in this section.

†Includes redemption card for Standard Letter of Certification (SLC).

Approximate Jaw Depths for 799 Electronic Calipers					
	6" (150mm)	8" (200mm)	12" (300mm)	24" (600mm)	40" (1000mm)
Outside	1-1/2" (38mm)	2" (50.8mm)	2-1/2" (63.5mm)	4" (100mm)	6" (150mm)
Inside	5/8" (16mm)	3/4" (19mm)	23/32" (18.3mm)	11/16" (17.46mm)	11/16" (17.46mm)



SLIDE CALIPERS



Check out our website for interactive features at starrett.com



CARBON CALIPERS

5000, 5001 AND 5002 CARBON FIBER CALIPERS

0-40"

- Carbon fiber construction significantly reduces weight, improving maneuverability
- Titanium coated stainless steel outside measurement jaws for long life and superior flatness
- Coolant resistant
- Two preset modes, REF I and REF II, allow setting one mode to a setting master and a second to a zero setting
- Full-featured, sophisticated electronics with RS232 output
- Ideal for use with Starrett DataSure® Wireless Data Collection Systems using a 1500-3A-1N end node
- Will also transmit to PC through cable

FEATURES AND SPECIFICATIONS

- CR2032 lithium battery included
- Clamping screw
- Protective wooden case
- Resolution: 0.0005"/0.01mm

5000 AND 5002 ONLY

- mm/inch mode button
- On/Off button
- Hold feature will freeze the display when in REF I or REF II mode

5001 ONLY

- Mode and Set buttons
- Min/Max mode displays values referenced from the preset value of the REF mode the tool is in when entering MIN/MAX
- Tolerance mode to set upper and lower measurement tolerances
- Larger display with more information



5002BZ-16/400 with PT06138 Step Contacts



5002BZ-24/600 with PT06139 Conical Contacts



5002BZ-40/1000 with PT06137 Disc Contacts



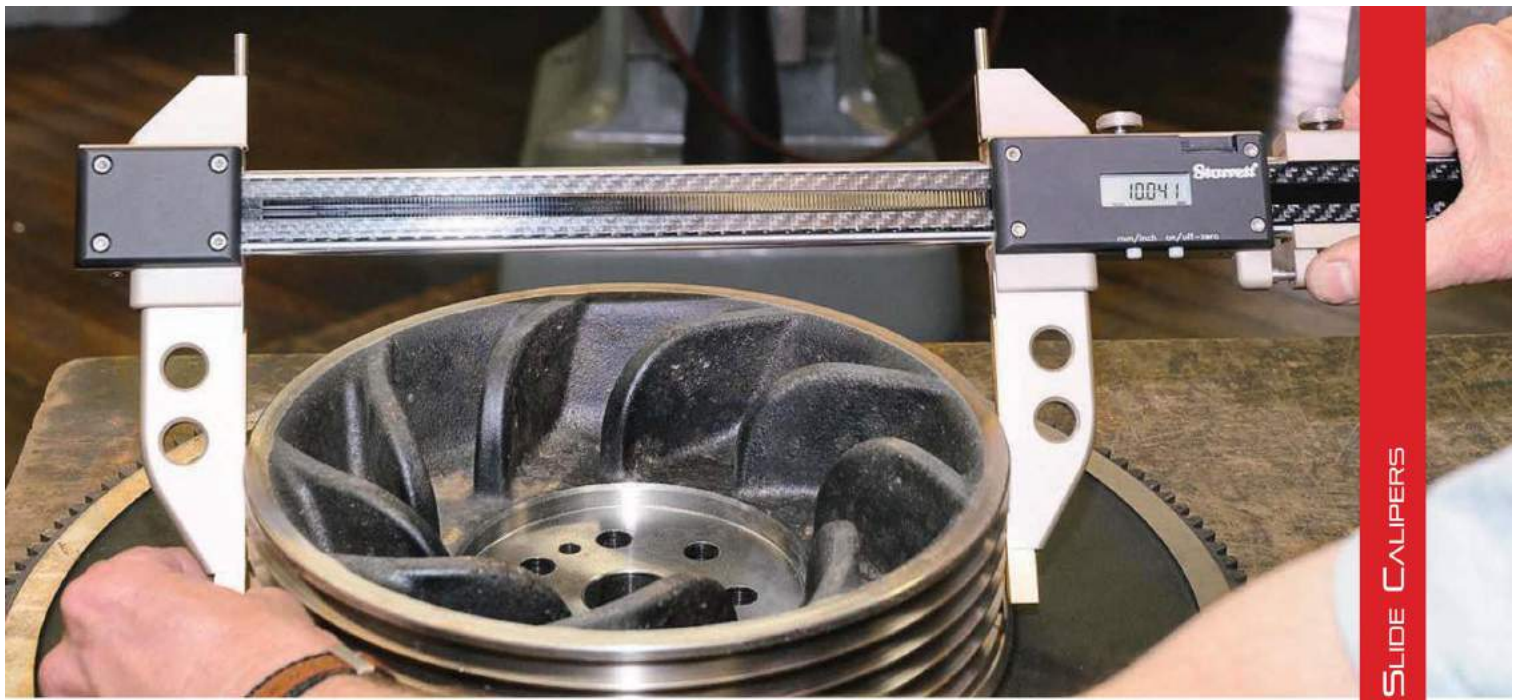

SLIDE CALIPERS



5000 Carbon Fiber Calipers

Cat. No.	EDP	Outside	Weight	Jaw Depth	Measuring Capacities	
B5000BZ-20/500	14571	0-20" (0-500mm)	2.43lb (1.10kg)	4.921" (125mm)	0.787-20" (20-500mm)	0.394-20" (10-500mm)
B5000BZ-24/600	14572	0-24" (0-600mm)	2.56lb (1.16kg)	4.921" (125mm)	0.787-24" (20-600mm)	0.394-24" (10-600mm)
B5000BZ-40/1000	14573	0-40" (0-1000mm)	3.09lb (1.40kg)	4.921" (125mm)	0.787-40" (20-1000mm)	0.394-40" (10-1000mm)

5001 Carbon Fiber Calipers

Cat. No.	EDP	Outside	Weight	Jaw Depth
C5001BZ-40/1000	14574	0-40" (0-1000mm)	5.51lb (2.50kg)	5.906" (150mm)
D5001BZ-60/1500	14575	0-60" (0-1500mm)	7.28lb (3.30kg)	7.875" (200mm)

5002 Carbon Fiber Calipers

Cat. No.	EDP	Outside	Weight
5002BZ-16/400	14576	0-16" (0-400mm)	1.65lb (0.75kg)
5002BZ-24/600	14577	0-24" (0-600mm)	1.98lb (0.90kg)
5002BZ-40/1000	14578	0-40" (0-1000mm)	3.31lb (1.50kg)

Accessories for 5002 Carbon Fiber Calipers

Part No.	EDP	Description
PT06137	12829	Disc Contacts
PT06138	12830	Step Contacts
PT06139	12831	Cone Contacts

Data Collection

Part No.	EDP	Description
797SCKB	69890	Uses cable direct to Computer with Excel
797SCU	29729	To Computer running on SPC Data Collection software



Check out our website for interactive features at starrett.com





ELECTRONIC CALIPERS

5005 ELECTRONIC LONG JAW CALIPERS

0-24"/0-600MM

The 5005 Electronic Calipers are built with extra long, 12" (300mm) jaws ideal for applications requiring precise O.D. or I.D. measurement in tight spaces that standard calipers can not reach.

FEATURES AND SPECIFICATIONS

- Hardened stainless steel construction for long life
- Tight, smoothly fitted slides for maximum accuracy and easy adjustment
- Coolant resistant
- Lock nut to hold measurements
- Fine adjustment thumbwheel
- Inch/mm conversion
- Ability to set ZERO at any position
- Two preset modes to install any reading at any point
- Full-featured, sophisticated electronics with Opto RS232 output
- Ideal for use with Starrett DataSure® Wireless Data Collection Systems using a 1500-3A-1N end node
- Will also transmit to PC through cable
- CR2032 lithium battery included
- Large easy-to-read display with resolution of 0.0005"/0.01mm
- Packed in a wood case
- Computers with Excel use 797SCKB
- Computers running SPC Data Collection use 797SCU



5005 Electronic Calipers

Range	Jaw Depth	Cat. No.	EDP
0-24" (0-600mm)	12" (300mm)	F5005BZ-24/600	14588



ELECTRONIC CALIPERS

5006 ELECTRONIC GROOVE CALIPERS

FEATURES AND SPECIFICATIONS

- Standard Measuring Tip Diameter: .118" (3mm)
- Two Preset Modes
- Hold Feature will freeze the display when it is in preset mode
- On/Off Button
- RS232 port allows data transmission thru a DataSure® Wireless Data Collection System using a 1500-3A-1N End Node. Will also transmit through a connected cable
- CR2032 lithium battery included
- Includes wooden case
- Resolution: 0.0005" (0.01mm)
- Generous diameter and jaw depth capacities
- Ideal for measuring internal and external grooves on large workpieces
- Hardened stainless steel construction
- Coolant resistant
- RS232 output
- Work well with Starrett DataSure® Wireless Data Collection Systems



SLIDE CALIPERS

5006 Electronic Groove Caliper	
Cat. No.	EDP
5006BZ-14/350	14589

Data Collection		
Part No.	EDP	Description
797SCKB	69890	Uses cable direct to Computer with Excel
797SCU	29729	To Computer running on SPC Data Collection software

Specifications		
	Groove Measuring Range	Max. Depth
Outside	0-12.5" (0-318mm)	3.937" (100mm)
Inside	1.654-15" (42-381mm)	3.7" (94mm)



Check out our website for interactive features at starrett.com



DIAL CALIPERS

120, 120M Dial Calipers

0-12"/0-300MM



The Only American Made Dial Caliper ...

This is one of the handiest measuring tools available, used by mechanics and toolmakers everywhere. It is direct reading, reliable and accurate.

READABILITY FEATURES

- Sharp, clear dial graduations of .001" or 0.02mm – .100" or 2mm in one revolution
- Sharp, black graduations on the satin finished bar, every .100" or 1mm
- Choice of black, red, or white inch dials; millimeter dials are yellow

EASE-OF-HANDLING FEATURES

- Knife-edge contacts for both inside and outside measurements
- One hand use with the thumb-operated, fine adjustment roll
- Lock screw for dial bezel and for holding the sliding jaw in position
- Detachable depth rod available for 12" (300mm) model
- Parallel lines can be scribed on a workpiece by setting the caliper jaw to the required dimensions, locking the movable jaw with the lock screw and then using the front edge of the fixed jaw as the scribing surface

ACCURACY AND LONG-LIFE FEATURES

- Long-wearing carbide faces on outside contacts on model 120AX-6 and 120MX-150 only
- Hardened stainless steel bar, measuring surfaces, rack, gears and depth rod
- Positive, split-gear anti-backlash control
- Rack teeth point down to make it easy to shed foreign matter and thereby keep the area clean



120A-6



R120A-6



B120A-6



120AM-150 metric dial caliper with yellow dial



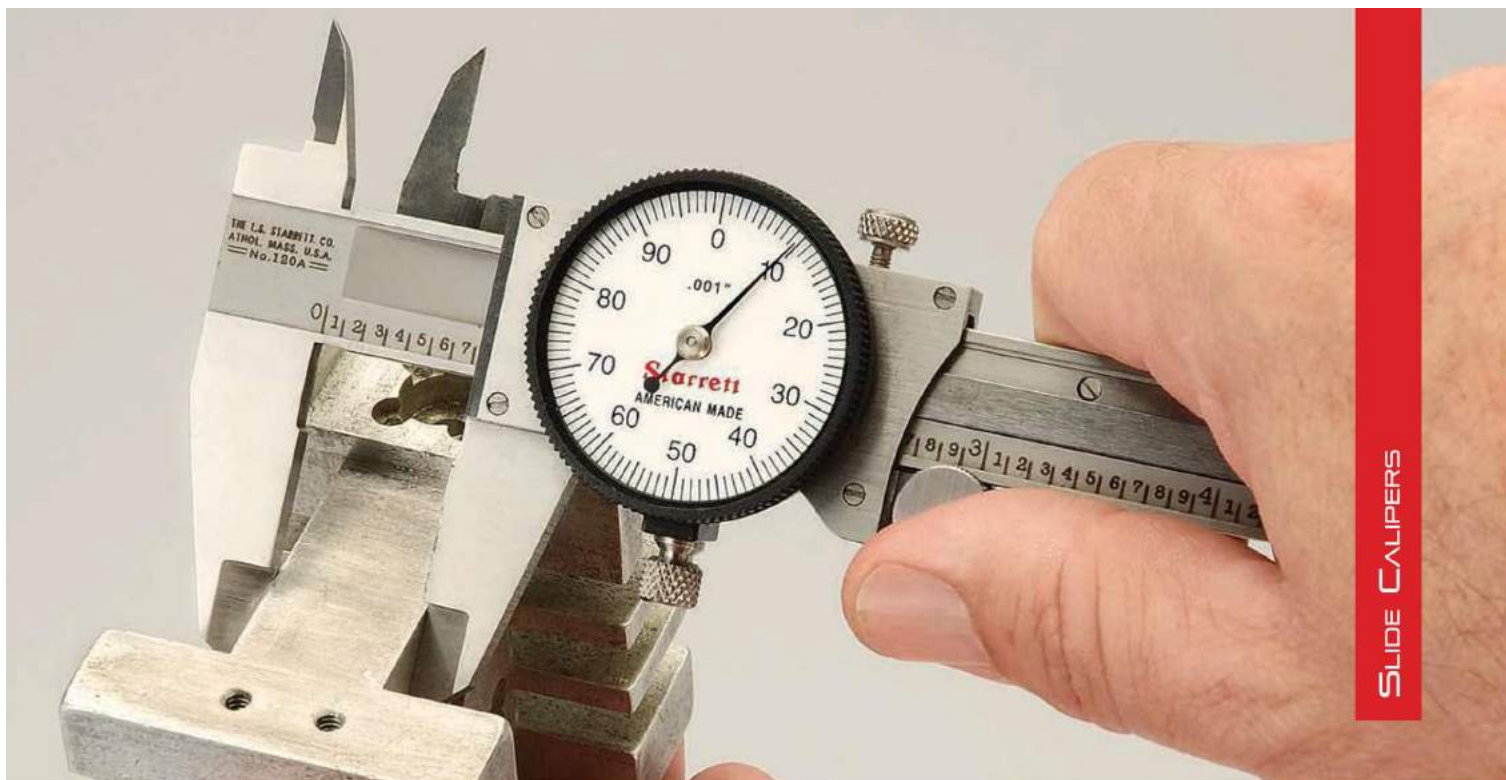

120 Dial Calipers (.001" Graduation)

Range	Dial Color	Jaw Depth		Description	Cat. No.	EDP
		Inch	mm			
0-6"	White	5/8"	16mm	Caliper in fitted plastic case	120A-6	64514
				Caliper in fitted plastic case	120A-6 W/SLC†	66568
		1-1/2"	38mm	Caliper in fitted plastic case	120X-6	65909
0-6"	Black	5/8"	16mm	Caliper in fitted plastic case	B120A-6	64515
		1-1/2"	38mm	Caliper in fitted plastic case	B120A-6 W/SLC†	66917
0-6"	Red	5/8"	16mm	Caliper in fitted plastic case	R120A-6	64516
		3/4"	19mm	Caliper in fitted plastic case	R120A-6 W/SLC†	66918
0-9"	White	5/8"	16mm	Caliper in finished Wood case	120AZ-9	64520
		1-1/2"	38mm	Caliper without Case	120A-9	64517
0-12"	White	3/4"	19mm	Caliper in finished Wood case	120Z-12	56693
					Caliper in finished Wood case	120Z-12 W/SLC†
		2-1/2"	63mm	Caliper without Case	120-12	56694
					Caliper without Case	120-12 W/SLC†

120M Dial Calipers (0.02mm Graduation)

0-150mm	Yellow		16mm	Caliper in fitted plastic case	120AM-150	66295
				Caliper, without case	120AM-150 W/SLC†	66920
			38mm	Caliper in fitted plastic case	120MX-150	65910
0-225mm	Yellow		16mm	Caliper in wood case	120MZ-225	64508
				Caliper without case	120M-225	64509
0-300mm	Yellow		19mm	Caliper in wood case	120MZ-300	64510
					Caliper in wood case	120MZ-300 W/SLC†
		63mm		Caliper without case	120M-300	64511
					Caliper without case	120M-300 W/SLC†

Accessories and Cases Only for 120 and 120M Dial Calipers

Description	Cat. No.	EDP
Center distance attachment*	PT26151	64440
Depth attachment for 6", 9" and 150mm calipers	PT22431	64640
Detachable depth rod for 12" calipers	PT26091	65100
Deluxe padded case for 6" (150mm) calipers	943	55971
Finished wood case for 9" (225mm) calipers	950	63878
Finished wood case for 12" (300mm) calipers	946	56695
Leather holster for 6" (150mm) calipers	915	64166

† Includes redemption card for Standard Letter of Certification (SLC).

* See details in this section.



Check out our website for interactive features at starrett.com

97



DIAL CALIPERS

1202 DIAL CALIPERS

0-12"



With the ability to provide quick, accurate measurement of O.D., I.D. and depth, the dial caliper is the most versatile precision hand tool on the market.

1202 Dial Calipers are based on the caliper that has been the first choice of metal working professionals for decades. 1202 Dial Calipers are available in 4", 6", 8" and 12" versions.

READABILITY FEATURES

- Sharp, clear dial graduations of .001" with .100" per revolution (except for the 1202F Model – see below)
- Sharp, black graduations on the satin finished bar, every .100"

EASE-OF-HANDLING FEATURES

- Knife-edge contacts
- Thumb-operated fine adjustment roll
- Adjustable bezel
- Lock screws for sliding jaw and dial bezel

ACCURACY AND LONG-LIFE FEATURES

- Hardened stainless steel bar, measuring surfaces, rack, gears and depth rod
- Positive, spring-loaded double pinion anti-backlash control
- Fitted case

1202F FRACTIONAL DIAL CALIPERS

0-12"

The 1202F shows measurements as fractions on the yellow outer scale with 1/64th inch graduations, and decimal measurements on the white inner scale with 1/100th inch graduations.

FEATURES

- 1/64" graduations on the yellow outer scale, and .01" on the white inner scale.
- Except for dial graduation and color, 1202F Calipers have the same features as other 1202 Dial Calipers

1202 Dial Calipers

Range	Cat. No.	EDP
0-4"	1202-4	68814
0-6"	1202-6	66964
0-8"	1202-8	66979
0-12"	1202-12	66980

1202F Dial Calipers

Range	Cat. No.	EDP
0-6" Fractional	1202F-6	68931
0-8" Fractional	1202F-8	69757
0-12" Fractional	1202F-12	69758

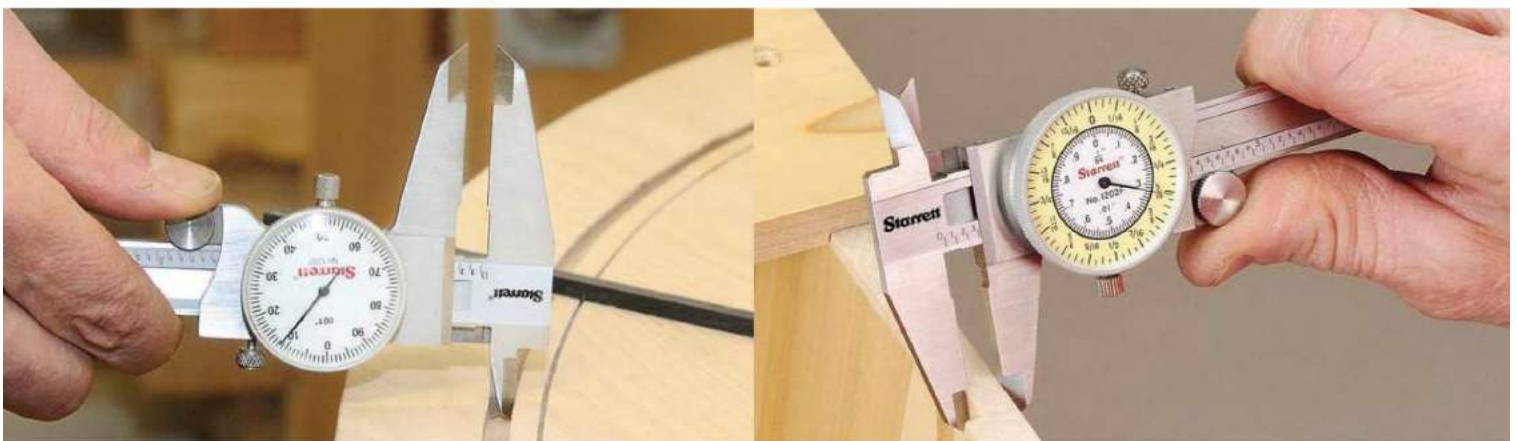

DIAL CALIPERS

120B, 120MB DIAL CALIPERS WITH LONG NIB JAWS

0-12"/0-300MM

This tool is a direct reading caliper with 3" (75mm) long jaws, ideal for heavy duty use and for gaining access to more measuring area than with conventional calipers. Strong inside and outside nibs measuring from zero for outside measuring and from .300" or 8mm for inside measuring.



120J OFFSET DIAL CALIPER

0-6"

This tool has an adjustable jaw for versatility when measuring different planes that can't be reached with a regular caliper. The reference jaw is adjustable in height to be either longer or shorter than the sliding jaw. All other features are the same as our 120 Dial Caliper.

- Adjustable jaw – 3-1/2" (88mm) long
- Extends up to 5/8" (16mm) longer than the sliding jaws
- Caliper in deluxe padded case



CENTER DISTANCE ATTACHMENT

PT26151

A set of two jaws with body sizes of .400" and conical points, enabling the user to measure the center distance between holes or center-punched locations that are at least .400" apart and less than .400" in diameter.

- Can be used with metric calipers by setting the caliper to 10.16mm
- Will fit Starrett 797, 798 and 120, 6" through 12", 123, 6" through 24", and 1202, 4" through 12" sizes

120B and 120MB Dial Calipers with Long Nib Jaws

Cat. No.	EDP	Range	Dial Color
120B-12	65067	0-12"	White
120MB-300	65154	0-300mm	Yellow
120MB-300 W/SLC*	66923		

* Includes redemption card for Standard Letter of Certification (SLC).

120J 0-6" Offset Dial Caliper

Cat. No.	EDP
120JZ-6	65866

Center Distance Attachment

Cat. No.	EDP
PT26151	64440



Check out our website for interactive features at starrett.com



VERNIER CALIPERS

123, 123M, 123EM MASTER VERNIER CALIPERS 0-72" AND 0-24"/0-600MM

Ultimate example of slide caliper design. It is more accurate, has the easiest reading vernier style, is stronger and offered in much longer lengths than other slide calipers.

READABILITY FEATURES

- Long 50-division vernier scales permit half as many bar graduations as conventional single-vernier tools. These widely-spaced graduations make it easy to read to .001" or 0.02mm
- The open-face design of the slide allows both the inside and outside vernier scale on the same side, thus allowing both verniers to be read without turning the tool over
- Black lines and figures against the Starrett satin chrome finish make reading a pleasure, not an effort
- Screw-type adjusting nut allows for fine measuring adjustments and lock nut holds measurements

LONG-LIFE AND ACCURACY FEATURES

- Fine tool steel construction makes the jaws harder and longer-wearing than stainless tools. All tools through 24" (600mm) also have hardened and stabilized bars.
- Hardened, ground and lapped measuring surfaces
- Machine divided graduations for accuracy
- The combination straight and angular ways on the master bar allow for positive alignment of graduations and easy adjustment of the flush-fitting verniers
- Sizes through 24" have divider points on the back side to accurately set dividers and trammels
- Tools with inch and millimeter graduations on the same bar have outside readings only. (Inside readings must be compensated for by adding the nib width to the indicated reading.)
- The longer length of the adjusting jaw slide provides a longer bearing surface on the master bar, ensuring squareness with the solid jaw and extra resistance to springing
- Tight, smoothly fitted slides for maximum accuracy and easy adjustment
- Fitted wood case option

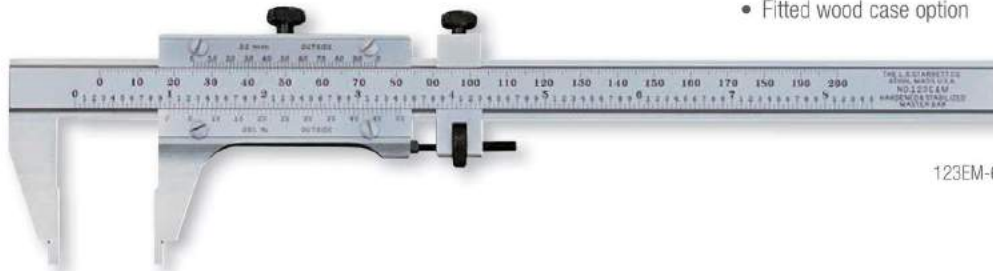

123EM-6

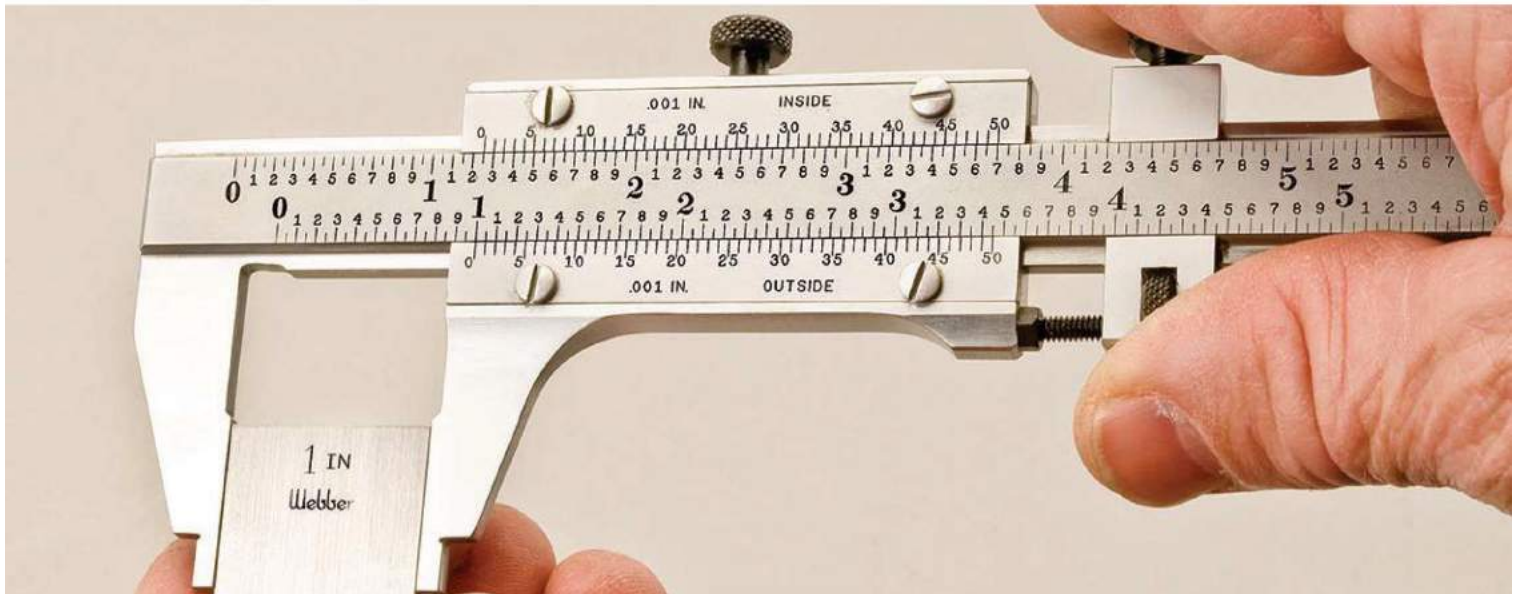

123 Master Vernier Calipers (.001" Graduation)					
Range	Bar Width	Approx. Jaw Depth	Max. Nib Width Closed	Cat. No.	EDP
0-6"	11/16"	1-9/16"	.250"	123Z-6	50524
				123Z-6 W/SLC*	66925
				123-6	50525
				123-6 W/SLC*	66926
0-12"	15/16"	2-5/16"	.300"	123Z-12	50526
				123Z-12 W/SLC*	66927
				123-12	50527
				123-12 W/SLC*	66928
0-24"	15/16"	2-5/16"	.300"	123Z-24	50528
0-36"	1-3/8"	3"	.500"	123Z-36	50530
0-48"	1-3/8"	3"	.500"	123Z-48	50532
0-60"	2-1/2"	4-1/2"	.750"	123Z-60	64383
	1-3/8"	3"	.500"	L123Z-60‡	63189
0-72"	2-1/2"	4-1/2"	.750"	123Z-72	64374
	1-3/8"	3"	.500"	L123Z-72‡	63190

123M Master Vernier Calipers (0.02mm Graduation)					
0-150mm	17.46mm	40mm	6.4mm	123M-150	56099
0-300mm	23.81mm	58mm	7.6mm	123MZ-300	56102
				123M-300	56101
0-600mm	23.81mm	58mm	7.6mm	123MZ-600	56104

123EM Master Vernier Calipers (.001" and 0.02mm Graduation)					
0-6" (150mm)	11/16" (17.46mm)	1-9/16" (40mm)	.250" (6.35mm)	123EMZ-6	50534
				123EM-6	50535
0-12" (300mm)	15/16" (23.81mm)	2-5/16" (58mm)	.300" (7.62mm)	123EMZ-12	50536
				123EM-12	50537
0-24" (600mm)	15/16" (23.81mm)	2-5/16" (58mm)	.300" (7.62mm)	123EMZ-24	50538

For Inside Measurements on 123M and 123EM Master Vernier Calipers		
Cat. No.	Range	Add Nib Thickness Below to Caliper Reading
123 E and M	0-6" or 150mm	.250" (Inch) or 6.35mm (Metric)
123 E and M	0-12" or 300mm	.300" (Inch) or 7.62mm (Metric)
123 E and M	0-24" or 600mm	.300" (Inch) or 7.62mm (Metric)

‡ Lightweight versions weigh approximately 10lb for the 60" model and 12lb for the 72" model. Regular 60" model weighs approximately 32 lb and the regular 72" weighs approximately 36lb
 Other sizes available on special order – priced on application. Special jaws priced on application.
 Hardened Bars on 6", 12" and 24" models: these models are also furnished with center points for dividers.
 * Includes redemption card for Standard Letter of Certification (SLC).

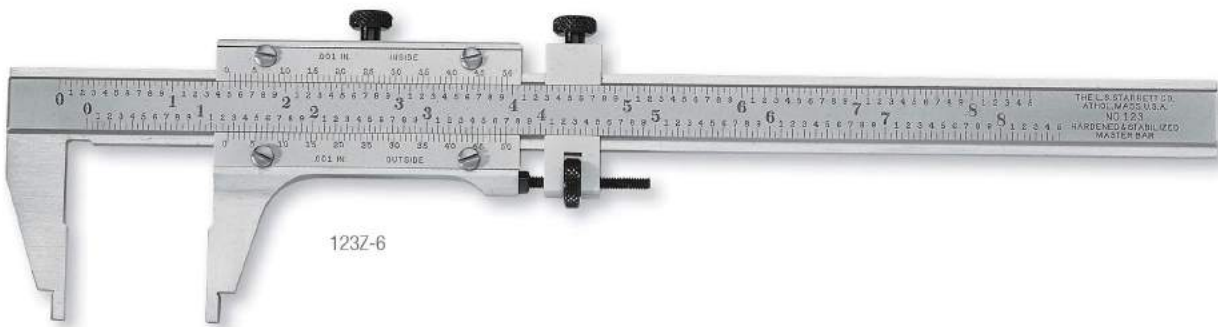

Check out our website for interactive features at starrett.com



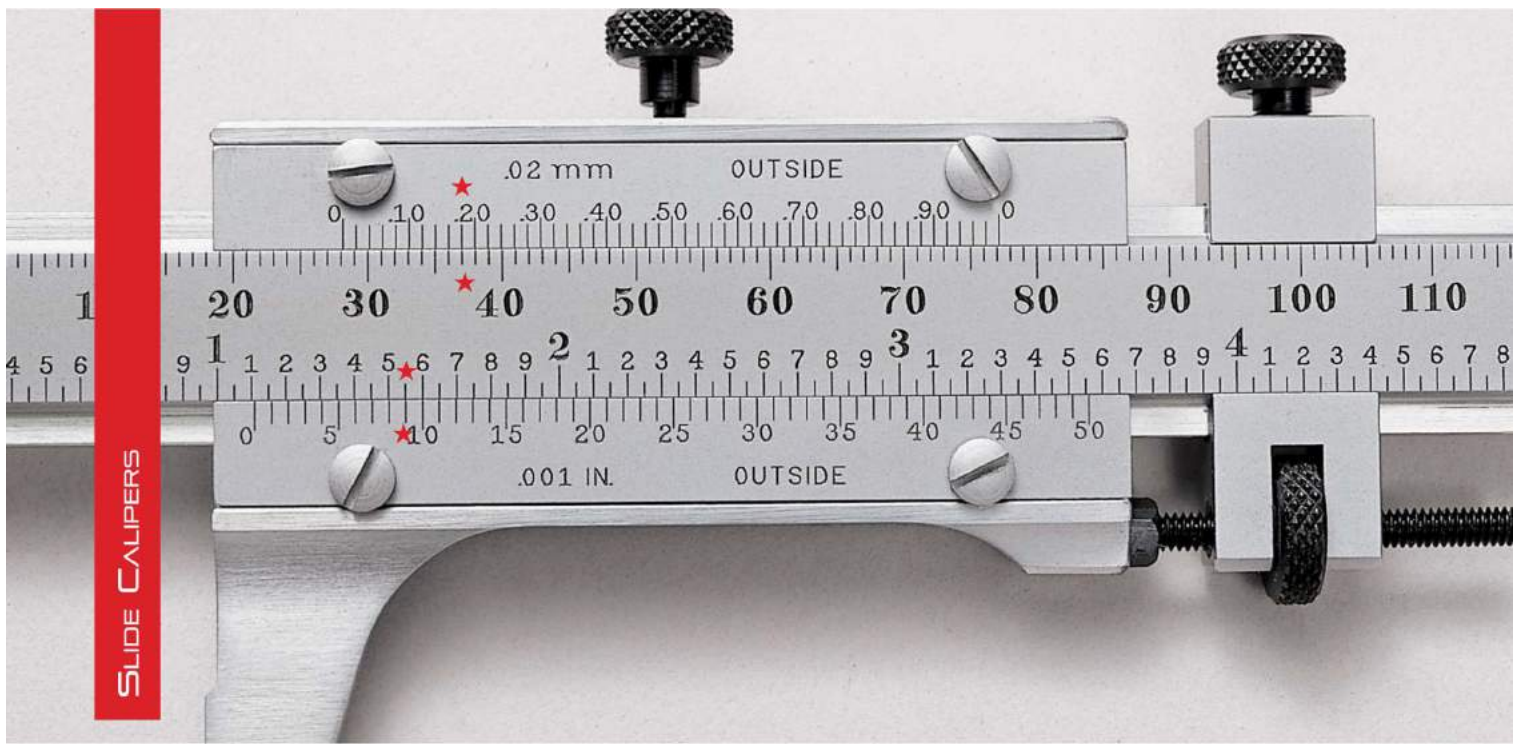

HOW TO READ A STARRETT 50-DIVISION VERNIER CALIPER GAGE

GRADUATED IN INCHES AND MILLIMETERS (DIRECT READING)

INCH READING

- Refer to the lower bar graduations and the inch vernier plate. Inches are numbered in sequence over the full range of the bar. Every second graduation between the inch lines is numbered and equals .100". Each bar graduation is .050"
- The vernier plate is divided into 50 parts, each representing .001". Every fifth line is numbered – 5, 10, 15, 20 ... 45, 50 – for easy counting
- To read the gage, first count how many inches and how many .050" lines lie between the zero line on the bar and the zero line on the vernier plate and add them
- Then count the number of graduations on the vernier plate from its zero line to the line that coincides with a line on the bar. Multiply the number of vernier plate graduations you counted by .001" and add this figure to the number of inches and .050" lines you counted on the bar. This is your total reading

EXAMPLE

- ★ In the photo, the vernier plate zero line is one inch (1.000") plus .100" beyond the zero line on the bar, or 1.100". The 9th graduation on the vernier plate coincides with a line on the bar (as indicated by stars). $9 \times .001"$ (.009") is therefore added to the 1.100" bar reading, and the total reading is 1.109"

MILLIMETER READING

- Refer to the upper bar graduations and millimeter vernier plate. Each bar graduation is 1.00mm. Every tenth graduation is numbered in sequence – 10mm, 20mm, 30mm, 40mm, etc. – over the full range of the bar. This provides for direct reading in millimeters
- The vernier plate is divided into 50 parts, each representing 0.02mm. Every fifth line is numbered in sequence – 0.10mm, 0.20mm, 0.30mm ... 0.80mm, 0.90mm – providing for direct reading in hundredths of a millimeter
- To read the gage, first count how many millimeters lie between the zero line on the bar and the zero line on the vernier plate
- Then find the graduation on the vernier plate that coincides with a line on the bar and note its value in hundredths of a millimeter. Add the vernier plate reading in hundredths of a millimeter to the number of millimeters you counted on the bar. This is your total reading

EXAMPLE

- ★ In the photo, the vernier plate zero line is 28 millimeters beyond the zero line on the bar, and the 0.18mm graduation on the vernier plate coincides with a line on the bar (as indicated by stars). 0.18 millimeters is therefore added to the 28mm bar reading, and the total reading is 28.18 millimeters



VERNIER CALIPERS

125 VERNIER CALIPERS

0-12"/0-300MM



- High quality, basic vernier caliper that offers inch and metric measurement
- Lock screw for sliding jaw
- Hardened stainless steel depth rod
- Graduations: .001" inch, 0.020mm metric
- Sharp, black graduations on the satin finished bar
- Fitted plastic case



125 Vernier Calipers

Range	Cat. No.	EDP
0-6" (0-150mm)	125MEA-6/150	61660
0-8" (0-200mm)	125MEA-8/200	61882
0-12" (0-300mm)	125MEA-12/300	61886

SLIDE CALIPERS

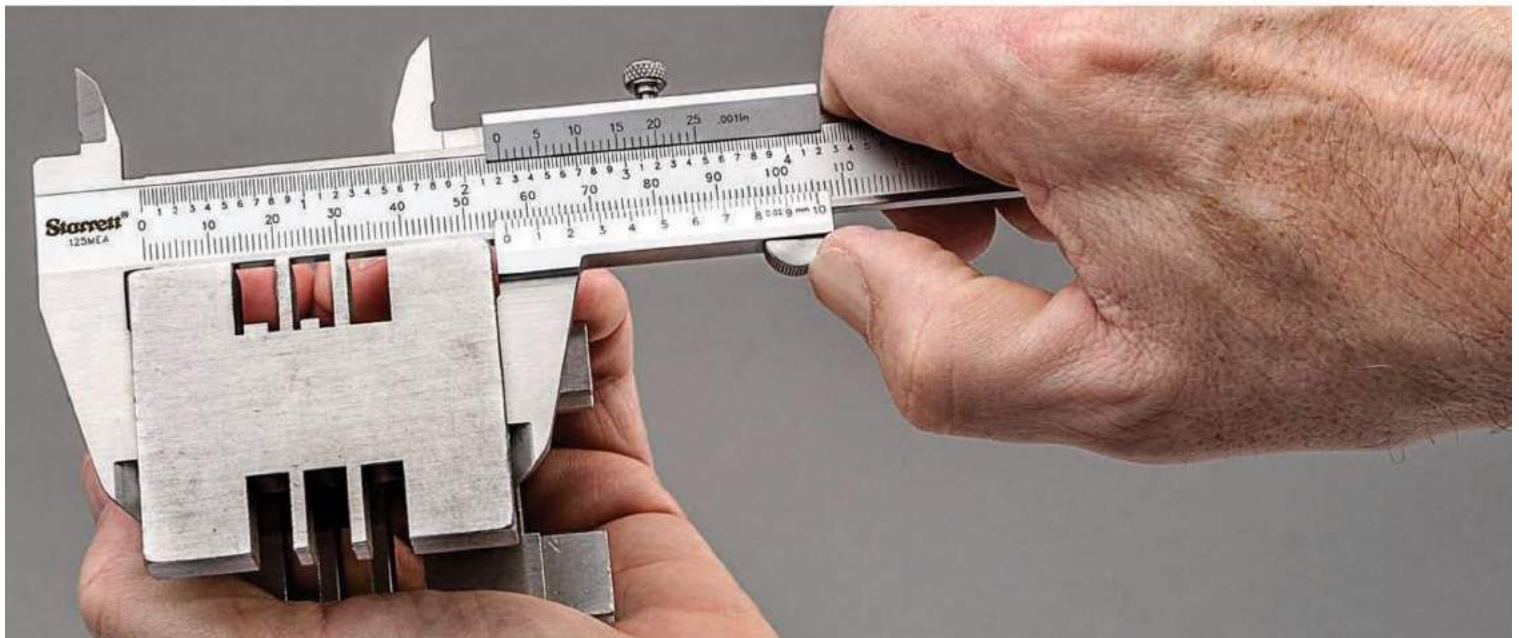

Check out our website for interactive features at starrett.com

103



VERNIER CALIPERS

456 GEAR TOOTH VERNIER CALIPERS 20-2 DIAMETRAL PITCH

456M GEAR TOOTH VERNIER CALIPERS 1-1/4-25MM MODULE

The 456 Gear Tooth Vernier Caliper is designed to measure in .001" or 0.02mm the thickness of gear teeth at the pitch line (the chordal thickness of the teeth) using the distance from the top of a tooth to the chord. For the same purpose, it can also be used for measuring hobs, form and thread tools, etc.

The thickness of a tooth at the pitch line is measured by an adjustable jaw after the addendum is set by the adjustable tongue. Each of these is adjusted independently by screws on the graduated bars.

Graduation – .001"		
Range	Cat. No.	EDP
20-2 Diametral Pitch	456AZ	52420
	456A	52422
10-1 Diametral Pitch	456BZ	52424
	456B	52426
Graduation – 0.02mm		
1-1/4-12mm Module	456MAZ	52421
	456MA	52423
2-1/2-25mm Module	456MBZ	52425
	456MB	52427

Available with carbide measuring surfaces on special order. Available with attractive, protective case – sent with case unless otherwise ordered. Packed one in a box.

FOR TOOL OPERATION:

- Find on the chart, furnished with the tool, the number of teeth of the gear in question, and find the corrected addendum (s"). This figure is for one diametral pitch for inch measure, so divide it by the diametral pitch number – this figure is also for a one millimeter module for metric measure, so multiply it by the required module number. This gives a corrected addendum for this particular number of teeth.
- Next, measure the actual outside diameter of the gear and add or subtract one-half the difference between the theoretical gear diameter and actual measured gear diameter from the corrected addendum (s") found in the first step.
- Set the new calculated addendum figure on the adjustable tongue of the tool.
- Now, with the tongue on the top of the tooth, measure the chordal thickness with the horizontal vernier jaw and compare with the figure in the "t" column in the chart.
- All inch graduations are read to .001". However the 456A is graduated by .020" increments and the 456B is graduated by .025" increments. 456MA and 456MB are read to 0.02mm and graduated by 0.5mm increments.

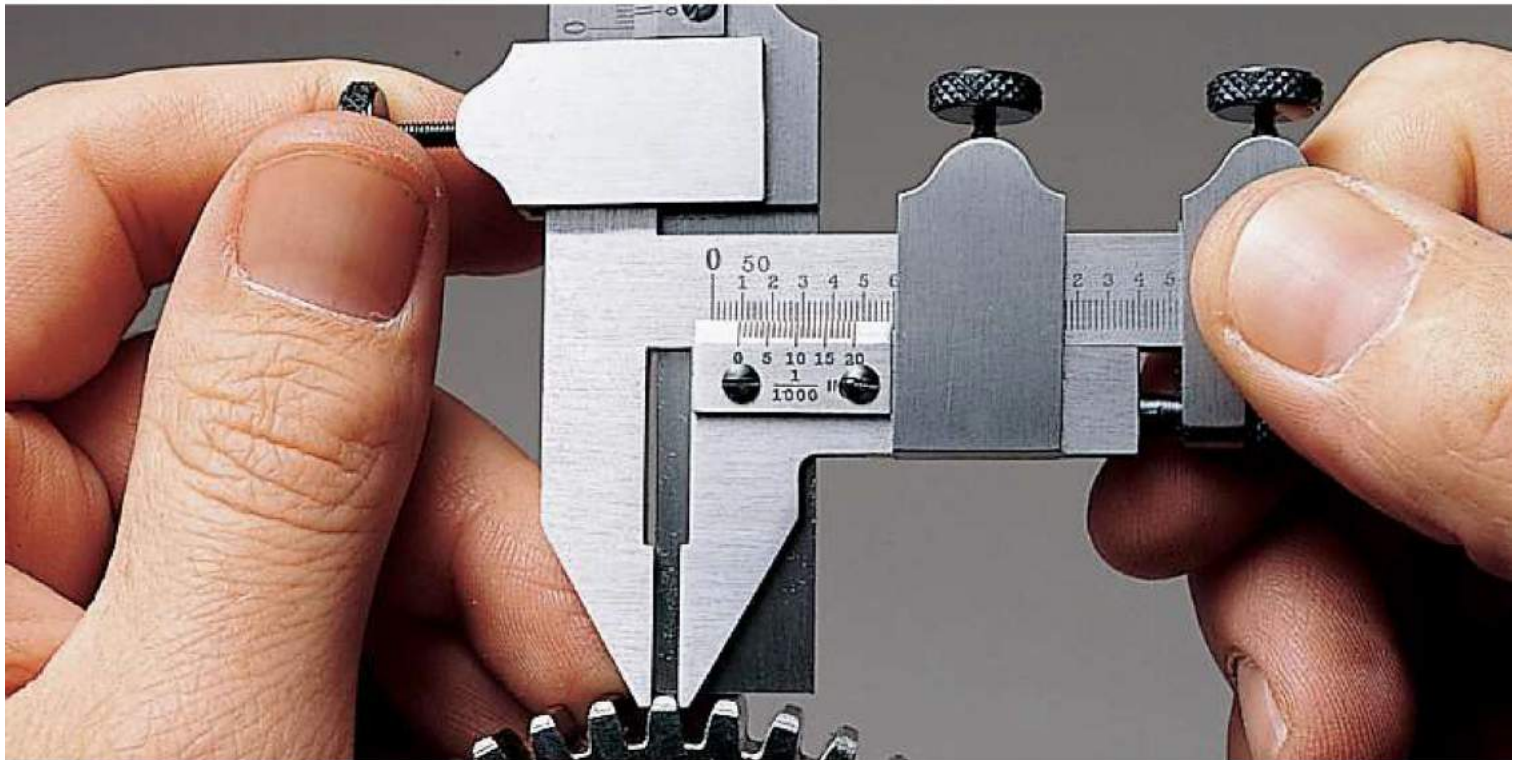

VERNIER CALIPERS

1223 SPECIAL MASTER DIAL INDICATOR VERNIER CALIPERS

2-48"

1223M SPECIAL MASTER DIAL INDICATOR VERNIER CALIPERS

50-900MM

The 1223 are so versatile that we make some models available as standard. However, special vernier tools like these can be built to your specifications by application through our Special Gage Department. The tool eliminates the need for skilled operator "feel" because it automatically sets in the correct gaging pressure.

Inch Reading						
Range	Vernier Graduation	Dial Gage Head Grad.	Range	Work Rest Adjustment	Cat. No.	EDP
2-18"	.001"	.0001"	±.020"	1/8-1"	1223-18	56137
2-24"					1223-24	56138
2-36"					1223-36	56139
2-48"					1223-48	56140
Millimeter Reading						
50-450mm	0.02mm	0.01mm	±1mm	3-25mm	1223M-450	64366
50-600mm					1223M-600	64382
50-900mm					1223M-900	64373

Available with finished wood case – sent without case unless otherwise ordered. Calibration master available at extra charge. Packed one in a box.

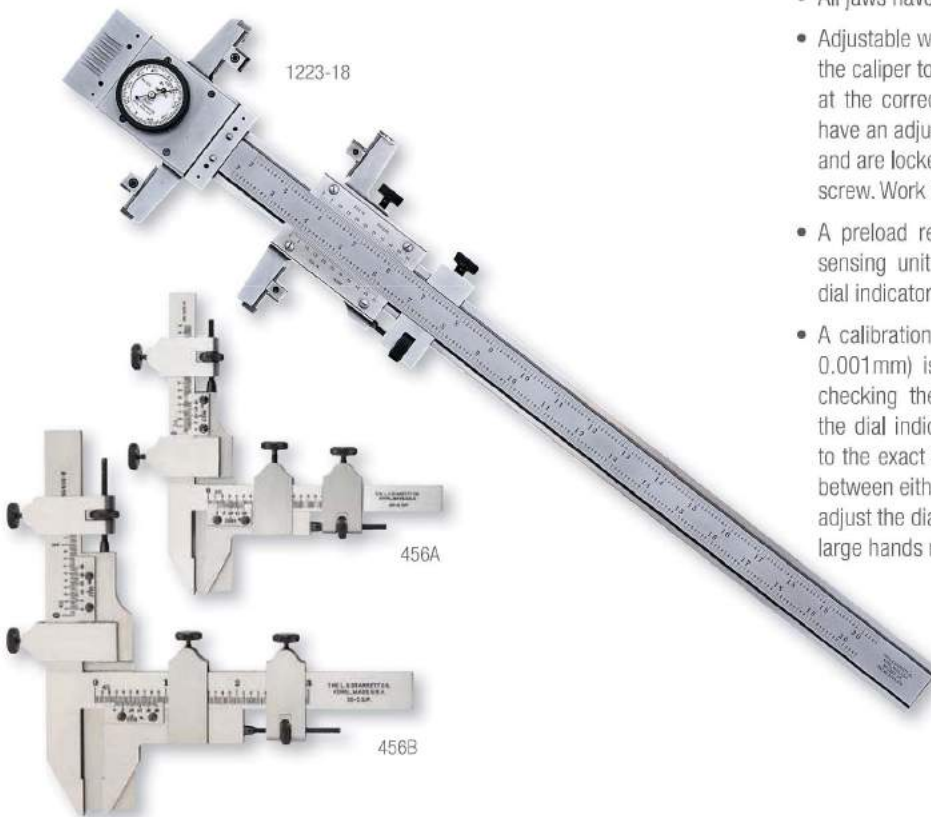

- Tool has the basic Starrett 123 Master Bar with all of its advantages
- The slide and the dial gage sensing unit have inside and outside measuring jaws
- Direct outside and inside measurements in .001" (or 0.02mm) are read from the vernier after the indicator is zeroed. Out-of-roundness can be checked within .0001" (or 0.01mm) using the dial gage
- The dial gage head or sensing unit has a slide mounted on preloaded ball bearings at the end of the caliper bar. Movement of the jaws on the sensing unit actuates a dial indicator graduated in .0001" (or 0.01mm) with one complete revolution reading .010" (or 1mm). The indicator has a total range of ±.020" (or ±1mm), each .010" indicated by a telltale hand. Plus graduations are shown in black and minus graduations are shown in red. The indicator can be set to zero by a fine adjustment screw or by the bezel.
- To use the caliper as a comparator, the vernier slide is set to the desired dimension and clamped. Plus or minus variations, outside or inside, are then read directly from the dial indicator
- All jaws have carbide measuring faces
- Adjustable work rests attached to the jaws permit the caliper to be placed on the work with the jaws at the correct measuring depth. The work rests have an adjustment range from 1/8-1" (3-25mm) and are locked in the desired position by a locking screw. Work rests are carbide-faced for long wear
- A preload reversing switch on the back of the sensing unit permits instant changeover of the dial indicator for outside or inside readings
- A calibration master accurate to ±.000050" (or 0.001mm) is also available at extra charge for checking the relation between the vernier and the dial indicator zero. To check, set the vernier to the exact size of the master, place the master between either the "inside" or "outside" jaws, and adjust the dial indicator so that both the small and large hands read zero

SLIDE CALIPERS



Check out our website for interactive features at starrett.com

105



POCKET CALIPERS

1025, 1025ME STAINLESS STEEL POCKET SLIDE CALIPERS

INCH READING 5", 6"/INCH AND MILLIMETER READING 5"/130MM

These handy tools permit quick, accurate outside and inside measurements. Their compact size fits easily in shop coat pockets. Calipers are made of fine quality stainless steel.

- Readings are made directly from the two lines marked "in" and "out" on one side of the stock
- Handy inch or millimeter scale on the back of the stock
- Knurled thumb pieces to activate the slide and slide stop prevents tool from being disassembled
- Knurled clamp screw with a left hand thread for easy one-hand operation
- Straight measuring surface for outside measuring and rounded nibs for inside or hole measurements



1025 Stainless Steel Pocket Slide Calipers									
Size	Range		Depth of Jaws	Width of Nibs Closed	Graduations		Cat. No.	EDP	
	Outside	Inside			Slide	Stock			
5"	0-3-3/4"	1/4-4"	1-3/8"	1/4"	32nds and 64ths	32nds	1025-5	53123	
6"	0-4-3/4"	1/4-5"	1-3/8"	1/4"	32nds and 64ths	32nds	1025-6	53124	
1025ME Stainless Steel Pocket Slide Calipers									
5" (130mm)	0-3-3/4" (0-96mm)	1/4-4" (6-100mm)	1-3/8" or 36mm	.236" or 6mm	64ths and 1/2mm	mm	1025ME-130	65860	
Cases for 1025 and 1025ME Pocket Slide Calipers									
Description							Cat. No.	EDP	
5" and 130mm Vinyl Case							1025ZZ-5	55289	
6" Vinyl Case							1025ZZ-6	55270	

424 STAINLESS STEEL POCKET SLIDE CALIPERS

3-1/2"

This extremely handy caliper gives direct readings of both circumference and diameter in a single setting.

- Especially useful for obtaining instant circumference and diameter measurements of rope, cordage, metal rods, pipe, tubing, etc. and for checking cutting speeds on lathe work
- 1-3/8" deep jaws will caliper a cylinder up to 2-3/4" diameter
- The upper edge of the slide is graduated from 0 to 11 circumference inches in 16ths and the lower edge

424 Stainless Steel Pocket Slide Caliper and Circumference Gage							
Size	Range		Graduations		Depth of Jaws	Cat. No.	EDP
	Dia.	Circumference	Dia.	Circumference			
3-1/2"	0-3-1/2"	0-11"	32nds	16ths	1-3/8"	424	51527



Cutting Speed in Feet per Minute = Circumference divided by 12 x Revolutions per Minute

