



Hand Tools

Product Grading



Production

High performance industrial tooling designed for continuous use applications on machine tools where repeatability and long tool life are of critical importance.



Professional

Industrial tooling that has enhanced features and benefits demanded by craftsmen and professional users.



Industrial

Designed for regular use in industrial applications. Manufactured to stringent quality levels and international standards.



Workshop

Standard quality tooling for use by tradesmen and generally industrial use.



Maintenance

Products designed for general maintenance of machines, workshops, garages and some household applications.



Home Improver

DIY quality tooling. Designed for home use and light industrial applications.

Product Groups 501 - 603



Contents

Description	Group	Page	Description	Group	Page
Adjustable Wrenches	501	330 - 331	Pin Spanners	581	511
Automotive - Battery & Electrical System Tools	503	332 - 333	Pipe - Benders	588	567
- Body Repair	503	334 - 338	- Cutters	588	566
- Braking System Tools	503	339 - 341	- Flaring Tools	588	568
- Compression Testers	503	342	- Pressure Testers/Tap Reseaters	588	568
- Cylinder, Piston & Valve Tools	503	343	- Threaders	588	569
- Inspection	503	344 - 345	- Vices	588	569
- Jacks & Stands	503	346 - 348	- Wrenches	588	570
- Nut Splitters	503	349	Plastering Tools	512	365 - 366
- Oil Filter & Sump Tools	503	350	Pliers & Grips	558	463 - 481
- Parts Washers	503	351	Punches & Stamps	560	482 - 483
- Pullers & Separators	503	352 - 355	Riveting Tools	569	484 - 485
- Special Tools	503	358 - 360	Roller Cabinets & Tool Chests	594	592 - 605
- Roadside Assistance	503	356	Roller Stands	588	572
- Timing Tools	503	345	Safety Tools	575	504 - 508
- Tyre Care	503	357	Saw Frames	538	444 - 445
Axes	525	415	Scaffolding Tools	580	510
Bolt & Cable Cutters	592	574 - 575	Scissors	533	430 - 431
Box Spanners	581	512	Screwdriver Bits	573	496 - 503
Brick Tools	512	367	Screwdrivers	572	486 - 495
Cable Ties	515	373	Service Cases	593	577
Cable & Wire Stripping Tools	516	374 - 376	Service Keys & Lifters	588	571
Chain Separators	588	564	Shears & Snips	591	573 - 574
Chain & Strap Wrenches	588	564	Sockets & Accessories - 1/4" Square Drive	582	528 - 531
Chalk Lines	597	628	- 3/8" Square Drive	582	532 - 535
Clamps	539	446 - 449	- 1/2" Square Drive	582	536 - 540
Cold Chisels, Pry Bars, Utility Bars	505	361 - 363	- 3/4" Square Drive	582	541
Contractor's Tools	522	401 - 405	- 1" Square Drive	582	542
Crimping Tools	515	368 - 372	Sockets & Accessories - Clips, Rails & Trays	582	543
Cycle Tools	595	618	Socket Sets - 1/4" Square Drive	582	545 - 546
Decorating Kits	533	428	- 3/8" Square Drive	582	547 - 549
Decorating Tools	533	422 - 429	- 1/2" Square Drive	582	550 - 554
Digital Levels	510	364	- 3/4" Square Drive	582	555
Drainage Equipment	588	565	- 1" Square Drive	582	555
Drawer Cabinets	593	576	- Mixed Drive	582	544
Engineer's Hand Tools	518	385 - 395	Sockets & Socket Sets - Ken-Grip®	582	526 - 527
File Handles	531	421	Soldering Tools	516	377 - 380
Fluid Handling	540	450 - 452	Spanners - Combination	582	512 - 518
Garden Tools	522	396 - 400	- Ring	582	519 - 521
Grease Nipples	541	456	- Open Ended	582	522 - 523
Hammer Shafts	530	421	- Miniature/Spanner End Fittings	582	524
Hammers	525	412 - 417	Spigot End Fittings	581	511
- Inserted Face	527	418 - 420	Stencils	561	483
Hexagon - Keys	601	630 - 631	Tape Measures	536	436 - 437
- Ball Drivers	602	632 - 634	Tool - Tethering	596	619
Impact Sockets - 1/4" Square Drive	583	556	- Bags	593	582 - 583
- 3/8" Square Drive	583	556 - 557	- Boxes	593	587 - 591
- 1/2" Square Drive	583	558 - 560	- Cases	593	584 - 586
- 3/4" Square Drive	583	561 - 562	- Control	595	606 - 607
- 1" & 1 1/2" Square Drive	583	562 - 563	- Kits	595	608 - 617
Insulated Service Tools	534	432 - 435	- Pouches	593	578 - 580
Ken-Grip® - Sockets & Socket Sets	582	526 - 527	- Rolls	593	581
Knives	537	438 - 443	Torque Tools	555	459 - 462
Laser Levels	510	364	TX Keys	603	635
Lubrication Equipment	540	453 - 455	Vice Grips	589	572
Magnetic Tooling	553	456 - 458	Water & Garden Accessories	523	406 - 411
Multimeters	516	381 - 384	Woodworking Tools	597	620 - 629
			Workshop Spanners	580	509 - 510
			Wrenches	582	525



Cushion Grip Adjustable Wrenches



Drop forged chrome vanadium steel with phosphate anti-corrosion finish. Hardened parallel opening jaws are ground and polished, laser etched with metric graduations for rapid repeatable reference setting. The wide grooved profile of the opening mechanism and coarsely knurled adjusting screw ensures smooth adjustment. Slim head profile allows easy access, the contoured jaws improve grip when used on damaged misshaped fasteners. The unique geomatic cushion grip improves user comfort, is resistant to oil and grease to provide a slip free grip. Securely bonded to the I-beam handle sub frame to prevent the ingress of oil and dirt.

Conforms to: **BS 6333-1995, DIN3117-1988.**



Tapered Jaw For Access Into Tight Spaces.



Length (mm)	Jaw Opening (mm)	Fastener Range	Order Code KEN-501
150 (6")	23.9mm	M2-M14 (1/8" - 9/16")	-3060K
200 (8")	28.6mm	M4-M18 (3/16" - 5/8")	-3080K
250 (10")	32.8mm	M6-M20 (1/4" - 3/4")	-3100K
300 (12")	38.1mm	M8-M24 (5/16" - 1")	-3120K

Twin Pack



2 PIECES

Contents	Weight each	Order Code KEN-501
200 & 300mm	800g	-0640K



Extra Wide Jaw Adjustable Wrench

Drop forged chrome vanadium steel. Rubber comfort grip handle. Ideal for use in plumbing, installation and automotive applications. Ultra thin head designed for use in confined spaces. Graduated millimetre scale. More than 50% wider jaw compared to conventional adjustable wrenches. Conforms to: **ISO 6787-1982, ASME B.107.8M-1996, BS 6333-1995, DIN3117-1988, JIS B4604-1976.**



Length (mm)	Jaw Opening (mm)	Weight each	Order Code KEN-501
150 (6")	0-34	315g	-5060K
200 (8")	0-38		-5080K
250 (10")	0-50		-5100K
300 (12")	0-60		-5120K

Set Number of Pieces	Contents	Order Code KEN-501
2	150 x 250mm	-5200K



Adjustable Wrenches



Manufactured from high strength 'I' beam section chrome or phosphate vanadium steel for improved strength and rigidity, the jaws are heat treated for extended tool life. High polished corrosion-resistant finish. 15° offset head angle for positive torque control. Slimline tapered jaws for improved access into confined spaces. Parallel jaws with smooth jaw adjustment and self-locking design prevents the jaws opening unintentionally even when under full load. Suitable for industrial engineering, automotive, agricultural, maintenance and assembly applications. Conforms to: **BS 6333-1995, DIN3117-1988.**



Tapered Jaw For Access Into Tight Spaces.

Phosphate Finish

Phosphate Finish

Length (mm)	Jaw Opening (mm)	Torque (kg/cm)	Weight each	Order Code KEN-501
100 (4")	17 (21/32")	714	60g	-0040K
150 (6")	24 (1")	1670	140g	-0060K
200 (8")	28 (1 3/32")	3100	260g	-0080K
250 (10")	33 (1 5/16")	5190	400g	-0100K
300 (12")	38 (1 3/8")	8820	650g	-0120K
375 (15")	50 (2")	17295	1040g	-0150K
450 (18")	60 (2 3/8")	23060	1670g	-0180K
600 (24")	70 (2 3/4")	25000	3300g	-0240K

Chrome Finish

Length (mm)	Jaw Opening (mm)	Torque (kg/cm)	Weight each	Order Code KEN-501
100 (4")	17 (21/32")	714	60g	-1040K
150 (6")	24 (1")	1670	140g	-1060K
200 (8")	28 (1 3/32")	3100	260g	-1080K
250 (10")	33 (1 5/16")	5190	400g	-1100K
300 (12")	38 (1 3/8")	8820	650g	-1120K
375 (15")	50 (2")	17295	1040g	-1150K
450 (18")	60 (2 3/8")	23060	1670g	-1180K

Phosphate Finish Sets

3 PIECES

2 PIECES



Number of Pieces	Contents	Weight each	Order Code KEN-501
3	100, 200 & 300mm	1100g	-0600K
2	150 & 250mm	540g	-0620K

Chrome Finish Sets

3 PIECES

2 PIECES



Number of Pieces	Contents	Weight each	Order Code KEN-501
3	100, 200 & 300mm	1100g	-1600K
2	150 & 250mm	540g	-1560K



YAMOTO Chrome Vanadium Adjustable Wrenches

Made of chrome vanadium with a corrosion-resistant satin finish, the Yamoto adjustable wrench delivers robust, hard wearing performance. Features a graduate laser etched jaw for fast jaw setting.



Length (mm)	Jaw Opening (mm)	Order Code
100 (4")	15	YMT-501
150 (6")	20	-3040K
200 (8")	25	-3060K
250 (10")	30	-3080K
300 (12")	35	-3100K
380 (15")	44	-3120K
457 (18")	50	-3150K
612 (24")	60	-3180K
		-3240K

Chrome Vanadium Adjustable Wrench Sets



2
PIECES

Contents	Order Code
150 & 250mm	YMT-501
200 & 300mm	-3400K
	-3500K

KENNEDY Combi Grip Adjustable Wrenches

These wrenches have a quick release reversible lower jaw with a serrated side with extra hard teeth for pipe gripping, a strong handle and a phosphated corrosion resistant finish. The smooth adjusting action makes them fast and easy to use.

Conform to: **ISO 6787-1982, ASME B.107.**

8M-1996, BS 6333-1995, DIN 3117-1988, JIS B4604-1976.



Length (mm)	Jaw Opening (mm)	Weight each	Order Code
250 (10")	30.0	345g	-4100K
300 (12")	35.0	890g	-4120K

ADJUSTABLE WRENCHES

GROUP
501



Chromed Drop Forged Adjustable Wrenches



Tapered jaws for improved access into confined spaces. Smooth jaw adjustment. Graduated laser etched jaw for fast jaw setting. Manufactured from chromed drop forged steel.



Length (mm)	Jaw Opening (mm)	Order Code
150 (6")	20	SEN-501
200 (8")	24	-4360K
250 (10")	30	-4380K
300 (12")	34	-4400K
		-4420K

Chromed Drop Forged Adjustable Wrench Set



2
PIECES



Contents	Order Code
150 & 250mm	SEN-501
	-4750K

Chromed Drop Forged General-Purpose Wrench

Made from fully chrome plated drop forged steel. Jaw opening capacity 68mm. 90° sliding jaw.

Overall length: 230mm.



Length (mm)	Jaw Opening	Weight each	Order Code
230 (9")	68mm	500g	SEN-501
			-5100K

PRODUCTS ARE ONLY AVAILABLE VIA YOUR DISTRIBUTOR

KENNEDY Circuit Continuity Tester

For testing circuit continuity on non-live systems. Locates broken circuits in fuses, switches, sockets and wires. 1m lead. Super sharp tempered steel probe to test through wire insulation.

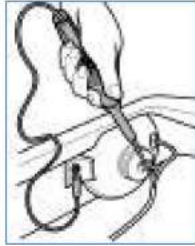

Requires AA battery (not supplied).

Model Number	Weight each	Order Code
CCT001	90g	KEN-503 -1000K

Standard Circuit Tester

Suitable for use with power on. For 6 and 12V automotive systems only. Locates shorts, earth and open circuits. 1m lead. Super sharp tempered steel probe to test through wire insulation. **Probe length: 45mm.**



For use on 6 and 12V

Model Number	Weight each	Order Code
SCT012	80g	KEN-503 -1020K

Commercial Duty Circuit Tester

Suitable for use with power on. For 6, 12 and 24V automotive systems only. Locates shorts, earths and open circuits. 1.4m heavy duty lead with spring strain relief. Super sharp stainless steel probe to test through wire insulation. **Probe length: 100mm.**



For use on 6, 12 and 24V

Model Number	Weight each	Order Code
CDT024	215g	KEN-503 -1060K

Long Probe Circuit Tester

Suitable for use with power on. For 6 and 12V automotive systems only. Locates shorts, earth and open circuits. 1.7m heavy duty lead with spring strain relief. Super sharp tempered steel probe to test through wire insulation. **Extra long probe length: 180mm.**

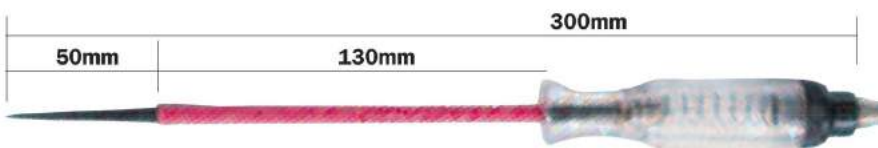

For use on 6 and 12V

Model Number	Weight each	Order Code
XCT012	245g	KEN-503 -1040K

Standard Automotive Fuse Set



An assortment of standard automotive bladed fuses supplied in transparent storage box. Colour coded transparent fuse bodies. Rated to 32V.

Fuse material: zinc.
Plug-in fuse type: 3A, 5A, 7.5A, 15A, 20A, 30A (15 of each).
Plug-in fuse type: 10A (30pcs).

**120
PIECES**



Order Code
KEN-503
-9900K

High Amp Maxi Fuse Set

An assortment of Maxi (High Amp) automotive bladed fuses supplied in a transparent storage case. Colour coded transparent fuse bodies.

Fuse voltage rating: 32V.
Fuse material: Zinc.
Fuse types: 20A, 30A, 40A, 50A, 60A, 70A, 80A, 100A (6 of each).

**48
PIECES**



Order Code
KEN-503
-9920K

SENATOR Standard Auto Blade Fuse Set

Supplied in a transparent plastic box.

Contents:
10 each of 5, 10, 15, 20, 25 and 30 amp blade fuses.

new

**60
PIECES**



Order Code
SEN-615
-2000K

Quick Splice Set

For fast, simple and strong splicing of automotive electrical wires. Easy-to-use, no wire strippers or crimper required.

Maximum electrical rating: 600V.
Maximum temperature: 105°C.

Terminal material: brass.
Plating: tin insulation.

Material: PP.
Red: 0.5mm² x 1.0mm² (25pcs).
Blue: 1.5mm² x 2.5mm² (25pcs).

**50
PIECES**



Order Code
KEN-503
-9930K

KENNEDY **Booster Cables**

For use on cars and light commercial vehicles. High quality copper coated aluminium cables, colour coded (Red = positive, Black = negative) fully insulated clamps.

400A: Suitable for use on up to 2.5L petrol and 1.5L diesel vehicles.

500A: Suitable for use on up to 5.5L petrol and 3.0L diesel vehicles.



Supplied in Storage Bag

Model Number	Cable Length	Amp Rating	Core	Order Code KEN-503
KBC 400	3.5m	400	16mm ²	-5360K
KBC 500	4.5m	500	25mm ²	-5370K

Battery Booster Cable

For use on cars and light commercial vehicles. Easy starting with low power loss. Tangle-free copper cable with double insulation. Robust fully insulated colour coded clamps. Heavy-duty storage bag.

Light Duty

Suitable for 12 and 24V systems. 3m cable. 16mm² multi-stranded cable core rated to 220amps.

Medium Duty

Suitable for 12 and 24V systems. 3.5m cable. 25mm² multi-stranded cable core rated to 350amps.

Heavy Duty

Suitable for 12 and 24V systems. 4.5m cable. 35mm² multi-stranded cable core rated to 480amps.



new

Model Number	Amp Rating	Weight each	Order Code KEN-503
BCC 16	220	1.80kg	-5200K
BBC 25	350	3.30kg	-5250K
BBC 35	480	4.30kg	-5280K

Booster Cables 300A

For use on cars and light commercial vehicles, these high quality, light duty copper coated aluminium cables are colour coded (Red = positive, Black = negative) and feature fully insulated clamps.

300A: 10mm² diameter cable suitable for use on up to 1.5L petrol vehicles.

Supplied in Storage Bag



Model Number	Cable Length	Amp Rating	Core	Order Code SEN-503
SBC300	2.5m	300	10mm ²	-1250K

Battery & Alternator Tester

Indicates condition of battery and the output of an alternator. For automotive use on 12V DC systems only. Magnetic back.

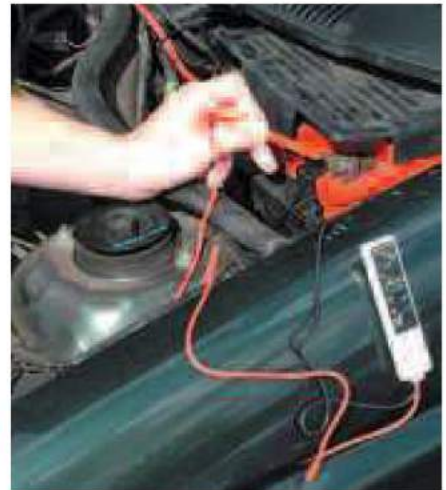

Test Voltage	Cable Length	Order Code KEN-503
12V	0.8m	-1080K

Battery Fluid Tester

Tests 6, 12 and 24V batteries. Tough glass tube construction with colour coded float for easy reading which indicates the state of charge in each cell. Displays the specific gravity with a scale range of 1.100 to 1.300.



Product Number	Order Code KEN-503
BFT624	-1120K

Automatic Battery Chargers

Robust battery chargers suitable for home and light workshop use. Simple and easy to use. LED indicators. For WET batteries, AGM technology and GEL batteries. Optimised charging programme. Efficient 3 stage charge. 100% rated output. Portable and lightweight. Intelligent circuit control and protection.



Max Rated Current	Input Voltage	Output	Order Code KEN-503
4A	220-240V 50hz	0.65A 12VDC1A 12DC4A	-0320K
8A	220-240V 50hz	0.80A 12VDC1A 12DC8A	-0350K

PRODUCTS ARE ONLY AVAILABLE VIA YOUR DISTRIBUTOR

KENNEDY 7-Piece Panel Beating Set
QUALITY INDUSTRIAL TOOLING



Supplied in a high quality fitted blow moulded impact resistant case. Drop forged, high carbon steel hammers with ground heads and cheeks. Hickory, octagonal section shafts. 1x: curved, utility, heel and toe dolly. 1x: 12oz shrinking hammer and flat faced bumping hammer, 1x 10oz round finishing pick.



7
PIECES



HAND TOOLS

Weight each	Order Code
7.40kg	KEN-503 -7650K

Panel Beating Dollies

Manufactured from drop forged medium carbon steel (SAE/AISI 1055). Heat-treated with a polished mirror finish.

Grid Dolly

For shrinking work. With a large crowned grid face on the surface and a plain flat face on the base this dolly, combined with a shrinking hammer and the use of heat, provides quick and effective shrinking.

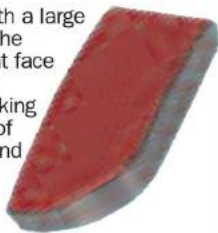

Length (mm)	Weight per 6	Order Code
120	7.10kg	KEN-503 -7500K

Utility Dolly

Double-sided multi-purpose. Use the edge most suited to the size and shape of a damaged flange.



Length (mm)	Weight per 6	Order Code
64	7.50kg	KEN-503 -7540K

Curved Dolly

For raising low spots on panels. The edge can also be used to restore the shape of a roof and reform beads.



Length (mm)	Weight per 6	Order Code
132	7.10kg	KEN-503 -7580K

Double-End Hand Dolly

For reshaping crowned panels and general panel beating.



Length (mm)	Weight per 6	Order Code
75	6.90kg	KEN-503 -7520K

Toe Dolly (Low Crown Dolly)

For reshaping. Can be used in the hand to deliver a series of blows to the underside of the panel. Long crown enables use in hard to reach areas.



Length (mm)	Weight per 6	Order Code
120	8.50kg	KEN-503 -7560K

Heel Dolly

For general reshaping of contoured panels, raising low spots and general panel beating.



Length (mm)	Weight per 6	Order Code
81	5.80kg	KEN-503 -7600K

Dent Puller Set

For repairing dents in body panels. Supplied complete with self tapping pull screw for use where access to the rear of the panel is blocked by reinforcements or other parts, a range of steel hooks and pull curls for pulling the edges of panels and a chain and hook. The long hammer shaft allows the pulling/striking force to be precisely controlled.

Contents: (1x) hammer (10lbs cast iron), 22.5Ø x 500 and 22.5Ø x 200mm pipes, 2 hole pipes, 6 x 170, 6 x 120, 6 x 200 and 3mm x 100mm plates, chain and hook, hex nut and blow moulded storage case.



9
PIECES



Product Number	Weight each	Order Code
DP9	9.00kg	KEN-503 -3460K

Trim & Upholstery Tool Set

Five piece set of angled lever tools designed for the easy removal of vehicle trim fasteners, mouldings and wheel hubs. Ideal for use inside and outside the vehicle, the tools are manufactured from plastic to avoid marking and scratching metal, wood or upholstery material.



5
PIECES

Order Code	KEN-503
	-1510K

AUTOMOTIVE - BODY REPAIR

GROUP
503



3 Piece Panel Seam Splitter Set

Ideal for separating spot-welded panels during repairs. Stainless steel coated chrome vanadium with through tang shafts allow use with hammers. Dual material soft grip handles for comfort and control. Includes 90°, curved and straight seam splitters. Cushioned handle absorbs any shock from hammer blows. Made from super tough alloy steel.



3
PIECES

Weight each	Order Code
94g	KEN-503 -7710K

Spot Weld Remover

Suitable for cutting holes in steel metal, steel, plastic and brass. The hardened steel cutter is reversible increasing tool life. Adjusting the spring loaded centre point screw accurately controls the depth of cut allowing the top to be removed whilst leaving the lower panel in place.

Spring loaded centre point guides cutter crown onto spot weld.

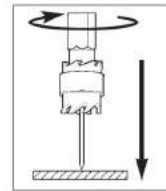

Cutting depth by screw permits top panel to be removed leaving the lower panel.

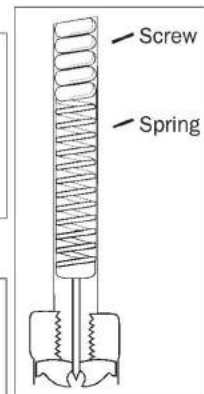
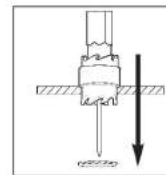

Fine adjustment of cutting depth by screw.

Capacity (mm)	Shank (mm)	Maximum Rated Operating Speed	Weight each	Order Code
10	6.5	900rpm	30g	KEN-503 -1200K

Trim Pin Remover

Designed for removing vehicle trim panels and upholstery. Also used for replacing door locks, window mechanisms and general bodywork repairs.



Overall Length	Weight each	Order Code
230mm	155g	KEN-503 -1500K

HAND TOOLS

PRODUCTS ARE ONLY AVAILABLE VIA YOUR DISTRIBUTOR

KENNEDY Hydraulic Body
Repair Kits

Porta Power with Ram & Spreader

Used for clamping, pulling, bending, straightening, spreading and lifting operations. Snaps together. Heavy-duty hand pump has automatic overload feature. Tough, blow moulded case. Strong flexible hose with spring guards at both ends. 10,000PSI hydraulic hand pump, 1/2 Tonne ram and spreader.



Body Repair Kit Spares

Description	4 Tonne		10 Tonne	
	Size	Order Code	Size	Order Code
Spreader Ram	-	-8240K	-	-8240K
Spreader Ram Repair Kit	-	-8250K	-	-8250K
Small Extension Tube	100mm	-8280K	125mm	-8420K
Medium Extension Tube	200mm	-8290K	250mm	-8430K
Long Extension Tube	305mm	-8300K	355mm	-8440K
Extra Long Extension Tube	410mm	-8310K	480mm	-8450K
Double Ended Male Snap Connector	-	-8320K	-	-8460K
Flat Base	114x63mm	-8330K	150x95mm	-8470K
90° V' Base	-	-8340K	-	-8480K
Wedge Head	-	-8350K	-	-8490K
Spread Plunger Toe	-	-8360K	-	-8500K
Spreader Ram Toe	-	-8370K	-	-8510K
Rubber Head	67mm Ø	-8380K	75mm Ø	-8520K
Serrated Saddle	35mm Ø	-8390K	46mm Ø	-8530K
Seal Repair Kit	-	-8000K	-	-8020K
Replacement Blow Mould Case	-	-8400K	-	-8540K

Kit Size	Stroke Length	Order Code
4 Tonne	100mm	-7240K
10 Tonne	150mm	-7260K

Single Speed Hydraulic Hand Pumps

Rugged construction with an internal overload valve, a pressure rating of 10,000psi (700bar) and a 1/4 NPT thread size. Operates in a vertical and horizontal position.



Model Number	Pressure Rating PSI (Bar)	Usable Oil Capacity	Oil Volume Per Stroke	Oil Port Thread	Length (mm)
HPS035	10,000 (700)	350cc	3.2cc	1/4 NPT	292
HPS060	10,000 (700)	600cc	3.2cc	1/4 NPT	478

Model Number	Weight each	Order Code
HPS035	5.70kg	-8800K
HPS060	7.10kg	-8820K

Spares

Description	Order Code
Connection Hose (1500mm x 1/4" NPT)	-8120K
Repair kit for HPS035	-8050K
Repair kit for HPS060	-8060K

Hydraulic Push Rams

Rugged construction with a heavy-duty return spring. Chrome plated piston inhibits rusting. 1/4 NPT thread size. Accessories easily snap on.



Model Number	Capacity (Tonne)	Stroke (mm)	Oil Cap (cc)	Cylinder Bore dia.	Length Ret.	Length Ext.	Outside dia. Piston	Oil Port Thread
HRP004	4	100	65	28.5mm	230	330	22 38	1/4 NPT
HRP010	10	150	243	45.0mm	325	475	33 57	1/4 NPT

Model Number	Weight each	Order Code
HRP004	1.80kg	-7170K
HRP010	5.30kg	-7190K

Twin Speed Hydraulic Hand Pumps

Rugged construction. Internal overload valve prevents it from being used beyond rated capacity. Operates in a vertical and horizontal position. Pressure rating 10,000psi (700bar). 3/8 NPT thread size. Pump handle locks into place to be used as a carrying handle.



Model Number	Pressure Rating PSI (Bar)		Usable Oil Capacity	Oil Volume Per Stroke		Oil Port Thread	Length (mm)
	Stage 1	Stage 2		Stage 1	Stage 2		
HPT035	200 (13.8)	10,000 (700)	350cc	7.0cc	1.0cc	3/8 NPT	310
HPT070	200 (13.8)	10,000 (700)	600cc	13.0cc	2.8cc	3/8 NPT	528
HPT250	200 (13.8)	10,000 (700)	2500cc	13.0cc	2.8cc	3/8 NPT	632

Model Number	Weight each	Order Code
HPT035	5.30kg	-8900K
HPT070	8.00kg	-8940K
HPT250	12.00kg	-8960K

Spares

Description	Order Code
Connection Hose (1500mm x 3/8" x 1/4" NPT)	-8140K
Repair kit for HPT035	-8080K
Repair kit for HPT070	-8090K
Repair kit for HPT250	-8100K

Hydraulic Pull Back Ram

Rugged construction with a heavy-duty return spring. Chrome plated piston inhibits rusting. 1/4 NPT thread size. Accessories easily snap on. For use with Porta Power/Body Dozer power units.



Model Number	Capacity (Tonne)	A Stroke (cm)	Cylinder Bore Diameter (mm)	B Overall Length (mm)	Oil Port Thread
HRP005	5	15	34	740	1/4 NPT

Model Number	Weight each	Order Code
HRP005	6.70kg	-7180K

KENNEDY Hydraulic Bench Presses

Ideal for pressing, bending and extruding. The Hydraulic pump can be manually operated or by compressed air connecting the airline supplied to an air supply line or direct to a compressor providing at least 8 - 9.5bar at 4cfm. Hydraulic gauge is included. Ideal for industrial and automotive applications.

20 Tonne

Sturdy steel frame with end braces and wide feet for extra stability. Work bed height is adjustable in 8 increments of 120mm, allowing large work pieces to be worked on with maximum flexibility.

30 Tonne

Heavy duty steel frame with end braces and wide feet for maximum stability. Work bed height is fully adjustable in 7 increments of 140mm, giving increased flexibility when working with large work pieces.

For use with	Work Bed Adjustable Height	Order Code
20 Tonne	8 Increments of 120mm	-9460K
30 Tonne	7 Increments of 140mm	-9470K

Seal Repair Kits

For use with	Order Code
20T Ram	-8550K
20T Pump	-8560K
30T Ram	-8570K
30T Pump	-8580K

Spares

For use with	Order Code
20T Hydraulic Pressure Pump	-3940K
20T Ram Assembly	-5241K
30T Hydraulic Pressure Pump	-3950K
30T Ram Assembly	-5242K

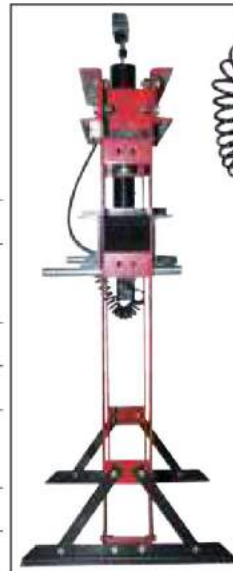

Hydraulic Bench Press

Ideal for pressing, bending and extruding. Built for tough daily use in industrial and automotive workshops, manufactured welded steel frame with two end braces for stability and a fully adjustable work bed providing flexibility and convenience. Fitted with a detachable pump and ram allowing hydraulics to be used for other purposes when the press is not being used. Hydraulic gauge is included.

Capacity: 10 tonnes.

These hydraulic presses are ideal for assembly, straightening, fabrication, quality control, maintenance, product testing, bending, forming, punching and shearing.

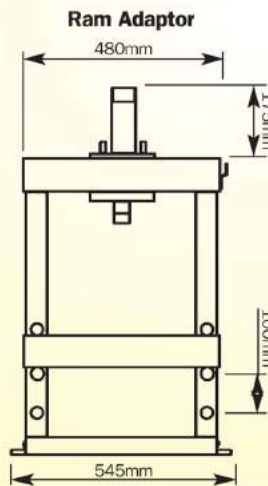
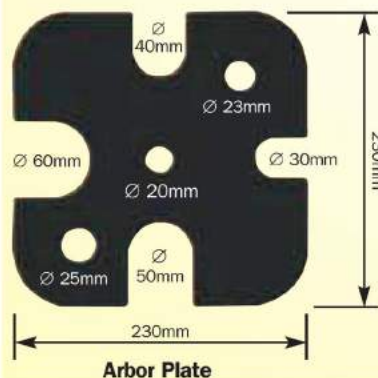
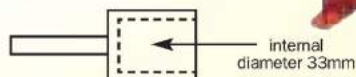
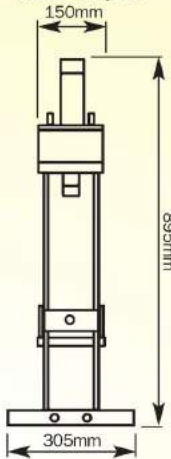
Model number	HBPO10.	1 tonne (metric ton or t)
Capacity10 Tonne.	= 1000kg
Ram stroke150mm.	1 ton (imperial ton)
Extension screw60mm.	= 2240lbs (1016kg)
Max height of ram to table ..	.300mm.	
Min height of ram to table ..	.90mm.	
Table aperture140mm.	
Working table width360mm.	
Overall height895mm.	
Hydraulic gauge included ...	Yes.	
Weight47kg.	

Ram Adaptor

Spare pump available - (KEN-503-8820K), see page 336.

Product Number	Weight each	Order Code
HBPO10	47kg	-5000K

Accessories		
Description	Weight each	Order Code
Seal Repair Kit	10g	-8220K
Pressure Gauge		-5570K

		Order Code
Hydraulic Ram		KEN-503
Arbor Plate		-1530K
		-7290K

PRODUCTS ARE ONLY AVAILABLE VIA YOUR DISTRIBUTOR

KENNEDY
QUALITY INDUSTRIAL TOOLING
**Lever Operated
Vacuums**

For use in hand lift applications only. Multiple vacuums used on a single load can only improve handling. If using more than one vacuum tool the ratio of maximum lift capacity does not increase. To lift heavier weights a larger vacuum must be used. All are fitted with a rubber suction cap which will not damage contact surface during the lifting action. For use on glass and plastic or any smooth surface material and can also be used for pulling out dents.

Single (VLS045)
Double (VLD070)
Triple (VLT070)



Model Number	Cups	Max Lift	Order Code
VLS045	1x10cm	45kg	-2620K
VLD070	2x12cm	70kg	-2640K
VLT070	3x12cm	110kg	-2660K

Filler Applicators

100mm wide plastic spreader, suitable for the application of auto body filler.



Size	Order Code
100mm (4")	-2820K

Auto Body Filler Applicator Set
4 Piece Set

Spring steel blades with composite grips. Suitable for the application of auto body filler.

Blade widths: 12, 25, 50 and 75mm.

Size (W x H x D): 123 x 210 x 5mm.



**4
PIECES**

Order Code
KEN-503

-2825K

**Universal Door Handle
Clip Remover**

Removes door panel clips without breakage. Simple action - insert the tool and push the clip out.



Size (mm) (W x H x D)	Weight each	Order Code
84 x 254 x 30	45g	-2790K

**Windscreen Moulding
Release Tool**

Removes trim moulding around cemented windscreen and rear windows quickly and easily.



Weight each	Order Code
90g	-2810K

Wax Injector Gun
WIG100

Pneumatic tool for spraying and injecting wax underseal into areas that are difficult to access, such as door cavities, inside box section chassis and around wheel arches. Has a 1ltr container with a 1/4" NPT connection, operates from 90 - 145psi (6 - 10bar) air pressure with an air consumption rate of 380ltr/min and a vacuum of (maximum) 550mm HG. Supplied with 900mm spray hose and hanging hook.



Order Code
KEN-503

-1880K

Universal Trim Pad Remover

For removing plastic interior trim retaining studs. Corrosion-resistant.



Size (mm) (W x H x D)	Weight each	Order Code
84 x 259 x 30	135g	-2800K

**Glass Run
Channel Cleaner**

Automotive glass run channel cleaners are for the fast removal of glass, chips and debris from run channels on side windows. Suitable for unhooking locking weather strips around windscreens, with a long shaft for reaching deep into door recess. Manufactured from hardened and tempered chrome vanadium steel with a comfort grip.



-8730K



-8710K

-8720K

Overall Length	Weight each	Order Code
260mm	150g	-8710K
330mm	190g	-8720K

Automotive Curved Hook Tools

Curved hook tools are for inserting and removing rubber seals and gaskets, they feature a long shaft and curved head for smooth operation in both directions. Manufactured from hardened and tempered chrome vanadium steel with a comfort grip.



Overall Length	Weight each	Order Code
230mm	120g	-8760K
295mm	150g	-8770K

**Windscreen Wiper
Arm Removal Tool**

Windscreen wiper arm removal tool for removing stuck and stubborn taper fitting wiper arms.

Maximum opening: 27mm.
Collar size: 15mm.



Order Code
KEN-503

-1570K

KENNEDY Brake Caliper Spreader

Retracting brake caliper pistons can be used with 1/2" square drive ratchet and 21mm hex wrench or spanner and is suitable for use on most cars and motorcycles. Constructed from hardened steel with phosphate finished spreader plates for corrosion protection.

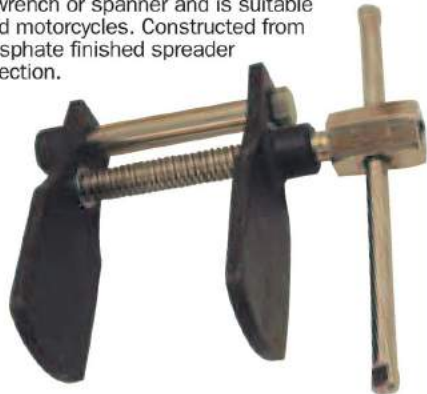

Product Number	Weight each	Order Code
BCS065	830g	-1900K

Brake Pin Punches

Parallel pin punches for the removal of brake caliper pad retaining pins. 6.0mm diameter punch uses a pilot tip to aid location in hollow pins used on GM/Vauxhall calipers.

Overall length: 165mm.



Diameter (mm)	Weight each	Order Code
5.5	95g	-4910K

Brake Spring Cup Washer Tool

Removes and replaces T-slot anti-rattle spring washers found in drum brake assemblies. Hardened and tempered carbon steel shank and cup with oxidised finish for protection against corrosion, bevelled and notched cup fits 16 - 22mm (5/8" - 7/8") diameter. Impact resistant square section handle for secure grip even when greasy.

Overall length: 152mm (6").



Product Number	Weight each	Order Code
BST122	110g	-4940K

Brake Clip Tool

Designed for import cars with brake shoe hold down clips. Removes and installs brake clip and nail on brake shoes in seconds. Impact resistant square section handle for secure grip even when greasy.

Overall length: 200mm (8").



Product Number	Weight each	Order Code
BSC150	165g	-4960K

Brake Fluid Tester (Battery Operated)

This ingenious tool is invaluable in the garage workshop for testing the quality of brake fluid. Testing for moisture content in the fluid by resistance to electric current. You get instant results from the built-in LED indicator light system. (Runs on 1x 1.5V AAA battery).



Order Code
KEN-503
-1130K

Universal Caliper Wind-Back Tool Kits

Winds back disc brake calipers when replacing brake pads. Professional quality, allows the easy return of brake piston into the caliper. Suitable for most braking systems.



Number of Pieces	Order Code
12	-2770K
18	-1890K

Brake Pedal Depressor

Ingenious tool for depressing and holding down the brake pedal whilst carrying out maintenance.

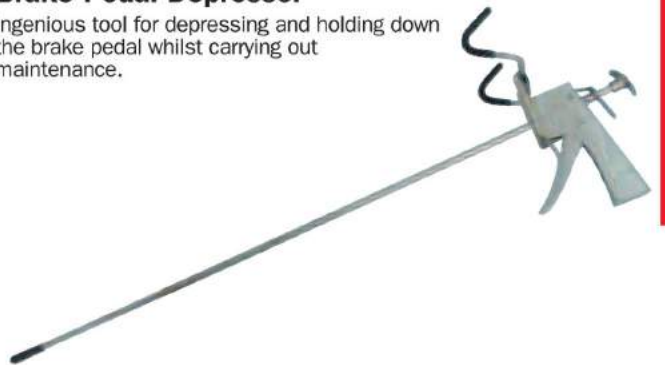

Order Code
KEN-503
-1910K

Brake Pad Key

8mm hexagon key. 140mm handle for optimum leverage and grip. Suitable for disc brake caliper retaining bolts on many modern cars. Manufactured from chrome vanadium steel with corrosion resistant phosphated finish.



Size	Weight each	Order Code
8mm Hex	245g	-2880K

PRODUCTS ARE ONLY AVAILABLE VIA YOUR DISTRIBUTOR

KENNEDY QUALITY INDUSTRIAL TOOLING **Vacuum Testing & Brake Bleeding Kit**

Vacuum testing kit that helps to locate and identify faults on cars, motorcycles and commercial vehicles. Supplied in robust blow moulded case.

Contents: serviceable metal bodied vacuum pump, reservoir jar, transfer lid, storage lid, 4x lengths of 6mm ID tubing, 1x length of 4mm ID tubing adaptor. Set of brake bleeding adaptors, rubber cup adaptor.

Maximum vacuum: 550mm Hg.

Reservoir capacity: 150ml.



Order Code
KEN-503

-2720K

Pneumatic Brake & Clutch Bleeder

PBB100

Has a 1ltr container with a 1/4" NPT connection, operates from 90 - 145psi (6 - 10bar) air pressure with an air consumption rate of 180ltr/min, an extraction rate of 1.6ltr/min and vacuum (max) of 550mm HG. Handles non-flammable liquids between 0 and 80°C.



Product Number	Capacity (litre)	Weight each	Order Code
PBB100	1.0	470g	KEN-503

-1920K

HAND TOOLS

Angled Flat Band Hose Clamp Pliers

Removes and installs flat band hose clamps. Swivel tips to grip at any angle. Locking handle allows user to maintain 'open' position and hold clamp in place.



Overall Length	Weight each	Order Code
215mm	200g	KEN-503

-1960K

Heavy Duty Hose Clip Pliers - Clic Compatible

With steel jaws and PVC coated handles. These spring loaded dual purpose pliers are designed for fitting and removing Clic and Clic-R® hose clips.



Overall Length	Weight each	Order Code
260mm	230g	KEN-503

-4810K

**Hose Pinch Clamp Set****HPS003**

These professional tools are for clamping flexible hoses from 11mm to 60mm in diameter. Made from a composite of glass reinforced nylon, they are lightweight, tough and have smooth rounded jaws to prevent damage to internal reinforcement.

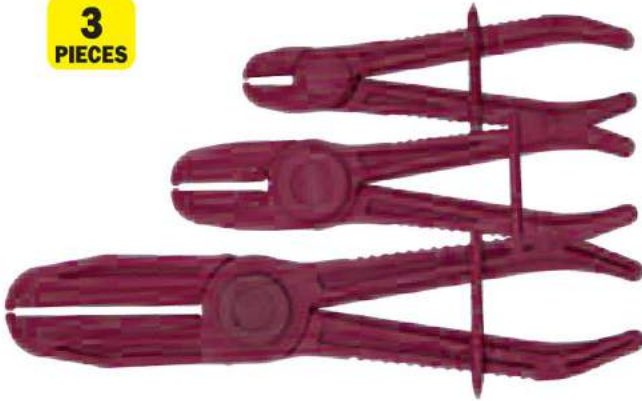
**3
PIECES**

Hose Range	Weight each	Order Code
11-60mm	330g	-1940K

Remote Hose Clamp Pliers

For the removal and replacement of fuel, oil and water hoses. Flexible 530mm long reach ratchet mechanism allows the pliers to release and lock hose clamps in the opened position. Supplied with cable clamping nipple for use when replacing the cable.



Capacity	Weight each	Order Code
55mm	575g	-1970K

Extra Heavy Duty Ear Type Clip Pliers

These pliers have steel jaws, PVC coated handles and a 1/2" sq for use with torque wrenches and bar breakers. Suitable for all ear type CVJ boot clips.



Product Number
AT4185

Order Code
KEN-503
-4820K

Spring Type Hose Pinch Tool

For clamping flexible brake lines, fuel lines, vacuum hose and other fluid lines up to 12mm diameter. Allows servicing to be carried out without the need for system draining. Sliding lock collar allows hoses to be fully or partly closed. Smooth rounded jaw edges avoid damage to hoses. All steel construction with corrosion-resistant chrome finish.



Maximum Diameter
12mm

Weight each
160g

Order Code
KEN-503
-2840K

Ratcheting Hose Pinch Pliers

For clamping flexible brake lines, fuel lines, vacuum hose and other fluid lines. Heavy duty serrated jaw edges provide excellent clamping whilst avoiding damage to hoses. Jaws pivot and self-level to ensure parallel clamping. Fine-adjusting ratchet action allows hoses to be fully or partly closed. Cocking mechanism holds pivot jaws firmly in position. All steel construction with corrosion-resistant finish.



Overall Length
200mm
250mm
300mm

Weight each
295g
435g
565g

Order Code
KEN-503
-2850K
-2860K
-2870K

HAND TOOLS**PRODUCTS ARE ONLY AVAILABLE VIA YOUR DISTRIBUTOR**

© 2018



KENNEDY Pressure Tester

Cooling System & Radiator Cap Pressure Tester
Designed for the pressure testing of cooling systems and radiator caps up to 35psi (2.5bar). Suitable for use on most makes of car and commercial vehicles, including: Mercedes, Ford, Chrysler, Peugeot, Honda, Lexus, Mazda, Suzuki, Toyota, Nissan, Opel, Volkswagen, Saab, Volvo, Audi, Citroen, Fiat and BMW.

Contents:
14 radiator pressure testing caps, for use in testing cooling systems for leaks.
Two cap adaptors, sizes 2 - 3 and 4 - 5, for testing radiator cap release pressure and seal condition.
Two 200psi coolant hoses (5/16" and 3/8"), for use with T-adaptor for in-line pressure testing.
T-adaptor for creating in-line pressure testing set-up.
Two 3/4" hose clips.

BEST SELLER



HAND TOOLS

Order Code
KEN-503
-0960K

Vacuum & Fuel Pump Tester

Suitable for use on most engines, from cars to commercial vehicles and most motorcycles. Large, easy to read dual calibrated colour coded scale. Suitable for all types of spark plugs. Can be used on crankshaft seals in two-stroke engines. Suitable for testing and finding fault in petrol engines with spark misfires, poor engine compression, weak/rich mixture, ignition over advanced/retarded, inlet manifold and carburettor air leaks, incorrect valve timing and poor fuel economy. Can be used for carburettor balancing, checking turbo boost pressure up to 0.7bar and fuel pump.



Weight each
440g

Order Code
KEN-503
-1140K

Compression Tester

Suitable for all types of spark plugs. Finds faults in piston rings, valves, head gaskets and cylinder bores. Suitable for use on most petrol engine vehicles and motorcycles. Can be used on crankshaft seals in two-stroke engines. 195mm flexible hose. For use on 14mm and 18mm threads. Large easy to read scale 0 - 21bar/0 - 300psi. Air release valve to allow rapid re-testing.



BEST SELLER

Weight each
440g

Order Code
KEN-503
-1160K

KENNEDY Cylinder Hone Set

Four different honing tools in one set suitable for honing/deglazing car brake and clutch cylinders, motorcycle, lawnmower, outboard motor engine cylinders, small bore car engine cylinders with capacities between 18 - 89mm. Self-aligning flexible shaft and leg assembly for smooth operation at all speeds and easy alignment. Honing diameter and pressure is adjusted via a simple, spring and cone mechanism. Suitable for use with a variable speed electric or air drill and fits into all three jaw chucks. Supplied in a plastic blow-moulded case.

Overall length: 200mm.

Set Contents: main honing body, twin leg set - 50mm, triple leg set - 50mm, triple leg set - 60mm; three sets of medium stones: 19 x 4.5mm (x3 off), 29 x 4.5mm (x5 off) and 51 x 7.0mm (x3 off).



Replacement Stone Sets - 3 Piece, Medium

L x W (mm)	Weight each	Order Code KEN-503
19 x 4.5	83g	-2990K
29 x 4.5	89g	-2980K
51 x 7.0	99g	-3000K

Type	Weight each	Order Code KEN-503
4-in-1	248g	-2930K

Piston Ring Compressors

Compresses piston rings into position reducing the risk of damage to components. Key operated with ratchet mechanism and safety valve. Made from tempered spring steel complete with steel key.

PRC-540

For passenger car vehicle engines.
Capacity: 57 - 125mm (2¼" - 5").
Height: 80mm (3¼").

PRC-730

For car/light commercial vehicle engines.
Capacity: 90 - 175mm (3½" - 7").
Height: 100mm (4").

PRC-765

For heavy commercial vehicle engines.
Capacity: 90 - 175mm (3½" - 7").
Height: 165mm (6½").



Model Number	Capacity (mm)	Order Code KEN-503
PRC540	57 - 125	-2210K
PRC730	90 - 175	-2240K
PRC765	90 - 175	-2270K

Valve & Piston Ring Compressors

Designed for use on production lines as well as in the automotive workshop. Able to cope with occasional commercial use. Manufactured from bright nickel plated steel with PVC cushion grips.



Opening Capacity	Throat Depth	Order Code KEN-503
Straight		
75-230	230	-2010K
Straight/Curved		
45-230	230	-2030K

Valve Spring Compressors

A unique 'direct action' compressor lever gives improved visibility and ease of use in areas of difficult access. In heavy duty steel with all rivetted joints and a slip resistant rubber handle.

VSC145

For use on large and diesel engines.

Restricted access adaptors: 25, 30mm.
Throat clearance: 250mm.



Capacity Min./Max.	Weight each	Order Code KEN-503
35-200mm	2.50kg	-2700K

VSC175

For use on multi-valve petrol and diesel engines with deep seated valves.

Restricted access adaptors: 25, 30mm.
Throat clearance: 165mm.
Packaging dimensions (W x H x D): 430 x 205 x 40mm.



Capacity Min./Max.	Weight each	Order Code KEN-503
55-175mm	2.20kg	-2710K

Piston Ring Pliers

Enables fast installation or removal of piston rings. A self-adjusting spring tensioned mechanism manufactured from nickel-plated steel with PVC handles for extra grip.

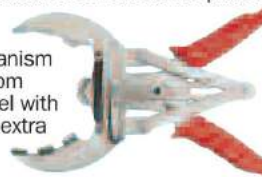

Model Number	Capacity (mm)	Order Code KEN-503
PRP100	50 - 100	-2090K

Cylinder Hones

Self aligning flexible shaft and leg assembly for smooth operation at all speeds. Honing diameter and pressure is adjusted via a simple, spring and cone mechanism. Suitable for use with a variable speed electric or air drill and fits into all 3 jaw chucks. For storage purposes legs are retained in position by a triangular clip. This can be removed using long nose pliers or tweezers and should be retained for further use. Replacement stone sets available. Use brake fluid for cutting lubricant.

0193

For honing of brake cylinders and piston bores with capacities between 19 - 68mm. Supplied complete with a medium grade stone set.

Overall length: 200mm.

0100

Heavy duty for honing of brake cylinders and piston bores with capacities between 51 - 178mm. Supplied complete with a fine grade stone set.

Overall length: 290mm.



Type	Weight each	Order Code KEN-503
3 Leg	105g	-2940K
Replacement Stones - 29 x 4.5mm		
Medium	83g	-2980K

Type	Weight each	Order Code KEN-503
3 Leg	380g	-2920K
Replacement Stone Sets - 100 x 9mm - 3 Piece		
Fine	88g	-2950K
Medium	93g	-2960K
Coarse	97g	-2970K

Straight Head Valve Seal Ring Pliers

For the easy removal of most valve stem seals and lower valve spring guides in restricted areas above the cylinder head. Gripping serrations inside the jaws aid gripping the outside diameter of the valve stem seal. Steel pliers with double rivetted metal handles.

Standard Overall length: 250mm, 50mm reach.



Extra Long Overall length: 270mm, 80mm reach.

Type	Order Code KEN-503
Standard	-2680K
Extra Long	-2690K

GROUP
503

AUTOMOTIVE - INSPECTION



**KENNEDY
PROFESSIONAL**

2-in-1 Padded Creeper Board & Seat

Heavy duty steel frame with powder coat finish. Vinyl coated cushioning. Quickly converts from creeper to seat. Adjustable back and parts tray when in the seat position.



Size L x W x H (mm)	Weight each	Order Code KEN-503
1050 x 480 x 100	13.0kg	-7300K

Padded Creeper Board

Both the creeper board and seat framework are manufactured from heavy steel with a powder paint finish. Furnished with a vinyl covered cushioning and are fitted with castor wheels for ease of movement.



Padded Creeper Seat

The creeper seat is fitted with a parts tray for tools and components.

Type	Size L x W x H (mm)	Weight each	Order Code KEN-503
Board	1050 x 480 x 100	7.00kg	-7320K
Seat	365 x 355 x 355	3.50kg	-7340K

Creeper Board with Magnetic Trays KMC01

High-impact moulded plastic creeper board lets you work under vehicles with ease. Low profile design to provide greater clearance. Padded headrest with removable magnetic tool trays and 6x75mm PVC coated caster wheels.



Capacity:
113kg (250lbs).

Size L x W x H (mm)	Weight each	Order Code KEN-503
1020 x 475 x 120	5.00kg	-7420K

**SENATOR
QUALITY TOOLING**

Lightweight Plastic Creeper Board

Durable, lightweight moulded plastic creeper board ideal for use in garages. Padded headrest with 4x 50mm polypropylene caster wheels.

Capacity: 127kg (280lbs).



Size L x W x H (mm)	Weight each	Order Code KEN-503
910 x 405 x 105	3.00kg	-7378K

344

PRODUCTS ARE ONLY AVAILABLE VIA YOUR DISTRIBUTOR

AUTOMOTIVE - INSPECTION/TIMING LIGHTS
KENNEDY Mechanic's Stethoscope

Professional stethoscope provides a fast and easy way to locate noises in engines or bearings and other moving parts. High quality surgical grade PVC and rubber parts for increased sound definition, plastic ear-pieces minimise outside noise with an aluminium alloy probe/needle for finding the exact location of specific noises. Supplied with rubber trumpet for checking vacuum and pressure flow. Useful for synchronising multi carburetors, helps to track dashboard rattles and is ideal for pinpointing unusual vibrations or suspected leaks, it is also shockproof.

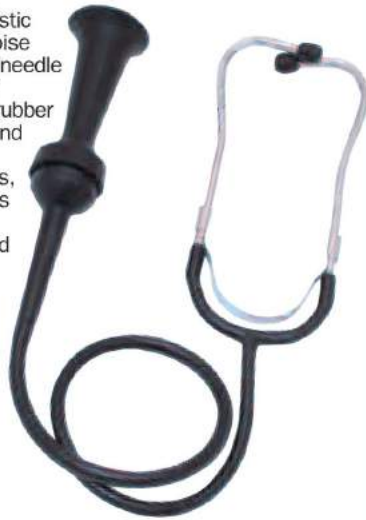

Product Number	Order Code
MSC110	KEN-503 -2740K

24 LED Worklight

LWL024
24 super bright LEDs. Magnetic base. Soft touch durable composite casing. 360° swivel hanging hook for hands free applications. Requires 3x AA batteries (not supplied). Lasts for 4 - 5 hours approx. IP20 moisture protection.

Length: 208mm.



Type	Weight each	Order Code
Battery Operated	260g	KEN-503 -5110K

Noid Light 6 Piece Test Set

NLT060
The Kennedy® Noid light test set is for diagnosing fuel injector signal faults fast. Simply disconnect the injector harness and plug in the relevant noid light. Turn the ignition on - if the light is constant or absent, then the signal from the ignition system is at fault. Easy to use and fits a wide variety of injector harnesses.

Compatible with: GM - TBI GM - SCPI. GM - PFI, FORD - TBI GEO - TBI BOSCH - PFI

6
PIECES



Product Number	Order Code
NLT060	KEN-503 -5020K

Standard Timing Light

For checking and setting ignition timing on automotive, agricultural and marine engines. For use on 12V systems. Reverse polarity protected. Accurate to 8,000rpm. 135cm long durable power leads. Impact resistant housing. On/off trigger switch. Bright linear Xenon flash tube for daylight use. Focused lens provides concentrated light. Easy to apply inductive impulse pick-up.



Order Code
KEN-503
-5340K

Advance Timing Light

For checking and setting ignition timing on automotive, agricultural and marine engines. Measures ignition spark advance from 0 - 60°. For use on 12V systems. Reverse polarity protected. Accurate to 8,000rpm. 1m long removable coiled power leads. Impact resistant metal case and rubber nose cone. On/off trigger switch. Bright linear Xenon flash tube for daylight use. Focused lens provides a concentrated light. Easy to apply inductive impulse pick-up. Built in check light.



Order Code
KEN-503
-5320K

PRODUCTS ARE ONLY AVAILABLE VIA YOUR DISTRIBUTOR

KENNEDY Trolley Jack
QUALITY INDUSTRIAL TOOLS

Strong steel chassis provides stability when under load. Fixed direction castors and swivel castors for easier positioning under vehicles. Long reach single piece pump handle with comfort rubber for rapid raising and lowering. Safety overload protection valve prevents overload damage to hydraulic mechanism. Integral carry handle.
GS and TUV approved.

- T238:** 525 x 225 x 145mm
- T2.249:** 695 x 344 x 180mm
- T280:** 1150 x 360 x 210mm
- HTJ03:** 630 x 344 x 180mm



T280 Model

Model Number	Maximum Load	Height (mm) Min. - Max.	Weight each	Order Code KEN-503
T238	2000kg	130 - 380	12.0kg	-6320K
T2.249	2250kg	145 - 495	36.5kg	-6350K
T280	2000kg	140 - 800	58.0kg	-6920K
HTJ03	3000kg	150 - 490	36.5kg	-6360K

Spares

Description	Order Code KEN-567
Torsion Spring for T280	-7880K
Torsion Spring for T2.249	-7860K
Seal Repair Kit for T238	-8160K
Seal Repair Kit for T2.249	-8180K

HAND TOOLS

Heavy Duty Trolley Jacks

Constructed from heavy gauge steel for heavy-duty use with a large diameter saddle for a secure hold under the jacking point. Extra long handle for easy access under bigger vehicles which also tilts and locks in three positions with a built-in handle mounted safety release to prevent accidental lowering of the load. A foot pedal pump and fine adjustment are fitted on the handle for optimum vehicle height. Automatic safety overload protection and rear toe plate for easy positioning.



Model Number	Max Load (kg/Tonne)	Min Height (mm)	Max Height (mm)	Saddle Ø (mm)	Handle Pieces (mm)	Handle Length (mm)	Chassis Length (mm)	Chassis Width (mm)	Chassis Height (mm)	Net Weight (kg)
T556	5,000/5	150	560	130	1	1,200	1,420	370	200	95.0
T1056	10,000/10	160	560	150	1	1,200	1,555	490	255	145.0

1 tonne (metric ton or t) = 1000kg.

1 ton (imperial ton) = 2240lbs (1016kg).

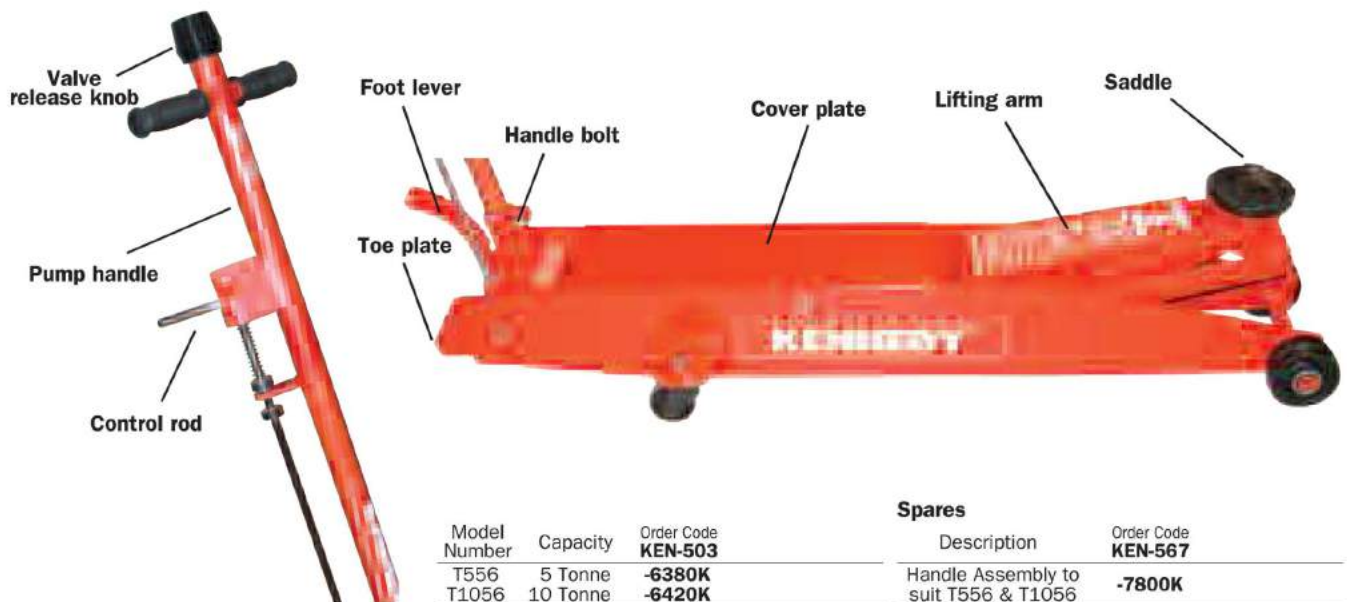

Model Number	Capacity	Order Code KEN-503	Description	Order Code KEN-567
T556	5 Tonne	-6380K	Handle Assembly to suit T556 & T1056	-7800K
T1056	10 Tonne	-6420K		

KENNEDY 3 Tonne Quick Lift Trolley Jack

3 tonne capacity. One stroke instant lift foot pedal, raises the saddle up to jack point to increase productivity. Constructed from heavy gauge steel. 1m, two-piece handle. 120mm diameter saddle. Automatic safety overload protection. Positive twist, lock and release mechanism. Heavy duty rear swivelling castor wheels.

Maximum load: 3000kg.
Minimum height: 145mm.
Maximum height: 490mm.

**QUICK
LIFT**



Dimensions

685 x 346 x 180mm

Model Number	Maximum Load	Height (mm) Min. - Max.	Weight each	Order Code
T349	3000kg	145 - 490	37.2kg	-7100K

2.5 Tonne Low Profile Quick Lift Lightweight Trolley Jack

3 tonne capacity. Made of a lightweight aluminium and steel construction. Its low profile makes it ideal for any type of car, including sports and race cars, and its swivel castor wheels enable easier positioning under vehicles. It also has a quick lift with dual pump and a rubber hand grip for user comfort.

**QUICK
LIFT**



Dimensions

685 x 345 x 180mm

Model Number	Maximum Load	Height (mm) Min. - Max.	Weight each	Order Code
QLT450	2500kg	100 - 460	28.5kg	-6540K

Spares

Description	Order Code
Seal Repair Kit	KEN-567 -2350K

Low Profile Service Trolley Jacks

Low Profile Trolley Jacks have strong, robust steel chassis to provide stability when under load. A low entry height. Heavy duty fixed direction castors and swivel castors ensure easy positioning under the vehicle prior to lifting. The pump handle with comfort rubber grip is to rapidly raise and lower the load arm and the vehicle. For use on firm level surfaces. **DO NOT** work under the raised vehicle until another means of support, such as axle stands are in place.

2 Tonne



Dimensions

T5359: 610 x 275 x 155mm
T450L: 640 x 345 x 175mm

2.5 Tonne



Model Number	Maximum Load	Height (mm) Min. - Max.	Weight each	Order Code
T5359	2000kg	89 - 359	14.5kg	-6520K
T450L	2500kg	85 - 450	34.0kg	-6530K

AUTOMOTIVE - JACKS & STANDS

2 Tonne Low Profile Long Reach Trolley Jacks

A low entry height Trolley Jack. Heavy duty fixed direction castors, swivel castors and inside wheel ensure excellent manoeuvrability and easy positioning under the vehicle prior to lifting. The foot pedal is to rapidly raise and lower the load arm and the vehicle. The long reach pump handle has a comfort rubber grip. Includes a practical tray for carrying tools and a rubber pad for the saddle. For use on a firm level surfaces.



Dimensions

T510L: 1010 x 365 x 135mm
T525L: 1150 x 350 x 180mm

Model Number	Maximum Load	Height (mm) Min. - Max.	Weight each	Order Code
T510L	2000kg	76 - 510	42kg	-6570K
T525L	3000kg	140 - 525	50kg	-6580K

Air Trolley Jack - 20/40T 2 Stage

For use when lifting heavy vehicles such as lorries etc. This industrial air jack has a robust steel chassis, 'T' bar handle with integral air control valve and two extensions for increased lifting height.



Air supply: 116 - 174psi (8 - 12bar).
Air consumption: 105ltr/min (3.7cfm).
Lifting capacity: 20T/40T.
Base height: 210mm.
Lifting height:
40T - 433mm,
20T - 520mm.
Air inlet size: 3/4NTP.

Dimensions

860 x 350 x 310mm

Model Number	Maximum Load	Height (mm) Min. - Max.	Weight each	Order Code
JTA2040	40T	210 - 520	61.0kg	-7120K

Hydraulic Trolley Jacks - 2 & 3 Tonne

Featuring steel chassis for stability, swivel castors for easier positioning and 1 piece handle with rubber grip for extra comfort. With overload protection valve, separate release mechanism and integral carry handle.



STJ330 (2 tonne)

Model Number	Maximum Load	Height (mm) Min. - Max.	Weight each	Order Code
STJ330	2000kg	135 - 330	8.5kg	-6320K
STL410	3000kg	130 - 410	15.8kg	-6360K

Spares

Model Type	Order Code
Seal Repair Kit for Sen-503-6360K	-0500K
Seal Repair Kit for Sen-503-6320K	-0510K

KENNEDY Bottle
Jacks

With large cast iron bases with a steel cylinder housing and an adjusting notched saddle. Fitted with an overload protection valve. Two piece 'pumping' handle also operates hydraulic release. Use on a firm level surface. **DO NOT** work under the vehicle until another means of support, such as axle stands, are used. Models B234, B337 and B541 are supplied in a robust blow moulded carry case. **Complies with the EC Machinery Directive. GS and TUV approved.** (Load ratings are 'metric tonnes' i.e. 1 tonne = 1,000kg). All supplied with spare seals.

2, 3 and 5 tonne jacks supplied in a robust plastic case



Model Number	Max Load (Tonne)	Height (mm) Min. - Max.	Max Saddle Adjustment	Weight each	Order Code KEN-503
B234	2	181 - 345	48mm	3.00kg	-5820K
B337	3	194 - 372	60mm	3.75kg	-5840K
B541	5	216 - 416	70mm	4.90kg	-5860K
B845	8	230 - 457	80mm	5.75kg	-5690K
B1246	12	230 - 465	80mm	7.50kg	-5710K
B1546	15	230 - 460	80mm	8.50kg	-5730K
B2045	20	242 - 452	60mm	11.0kg	-5750K

Ratcheting Axle Stands

Suitable for supporting raised vehicles or equipment. Protective red enamel coating. 10-position ratchet design that automatically locks when raised.



Capacity/pair	Per Stand	Min.-Max. Height	Order Code KEN-503
4 Tonne (4000kg)	2T	265-418mm	-5520K
6 Tonne (6000kg)	3T	280-420mm	-5530K
12 Tonne (12000kg)	6T	390-608mm	-5560K

Heavy Duty Bottle Jacks

With machined/cast steel bases and cylinder housings. Fitted with an overload protection valve. Three piece 'pumping' handle also operates hydraulic release. Use on a firm level surface. **DO NOT** work under the vehicle until another means of support, such as axle stands, are used.



Model Number	Max Load (Tonne)	Height (mm) Min. - Max.	Weight each	Order Code KEN-503
B3047	30	285 - 475	23.0kg	-5770K
B5048	50	300 - 480	34.0kg	-5790K

Scissor Jack

Made from heavy-duty steel with a rubber saddle which provides a positive grip and prevents damage to jacking points. Designed to safely raise vehicles. Easy to use and compact for easy storage. 1 Tonne (1000kg) safe working load. Wide base plate for extra stability.

Lifting range: 88 - 383mm.
Base plate size: 150 x 90mm.
Spindle thread: 12.5 x 2.5mm.



Model Number	Capacity	Weight each	Order Code KEN-503
KSJ010	1 Tonne	2.80kg	-5920K

500kg Engine Support Beam

For supporting and accurately positioning engines during maintenance operations and as an aid for the removal of gearboxes and transmissions. 500kg (1/2 tonne) capacity. Adjustable width to bridge various engine compartments. Fitted with soft rubber feet to protect the bodywork. Supplied with a 92cm long chain. Supporting legs can be tilted.



Capacity	Order Code KEN-503
500kg	-8100K

Telescopic Transmission Jack

Ideal for car and light commercial transmission removal and installation. Fully adjustable universal rotary saddle with adjustable corner brackets and safety chains. Foot operated pump and release valve leaves both hands free to manoeuvre transmission. Wide base with four 3" dia. swivel-type ball bearing castors providing stability and easy manoeuvring. Two-stage flash chromed rams inhibit rust from entering the hydraulic system. Lifts from 875 to 1800mm.

Contents	TTJ500
Capacity	½ Tonne
Ram Extensions	2
Minimum Saddle Height	875mm
Maximum Saddle Height	1800mm
Saddle Size	680 x 810mm
Chain Length	95mm
Saddle Tilt Forward	24°
Saddle Tilt Back	19°
Saddle Tilt Side	±20°
Saddle Return Weight	15.8kg (35lbs)
Base	695 x 805mm
Weight	68.5kg



1800mm

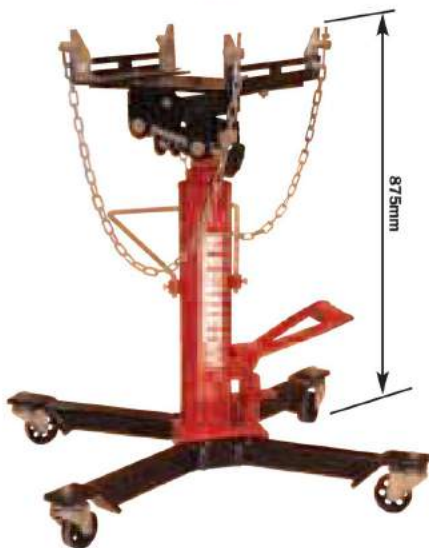

875mm

Model Number	Order Code
TTJ500	KEN-503
	-7160K
Description	Order Code
Seal Repair Kit	KEN-567
	-8210K

AUTOMOTIVE - NUT SPLITTERS

GROUP 503

Hydraulic Nut Splitter Set

The hydraulic ram provides up to 10 tonnes of direct non-twisting application of thrust that is more effective and secure than a mechanical thrust screw. Fully threaded body allows for quick and easy height adjustment. The splitter bodies are manufactured from carbon steel.

8 Piece Set contents:

- 1x hydraulic ram.
- 1x splitter body 3/8" diameter capacity.
- 1x splitter body 1/2" diameter capacity.
- 1x splitter body 5/8" diameter capacity.
- 1x splitter body 3/4" diameter capacity.
- 1x splitter body 1" diameter capacity.
- 1x threaded attachment sleeve.
- 1x oil bottle.

**8
PIECES**

Product Number	Weight each	Order Code
HNS100	4.45kg	KEN-503
		-4300K

Nut Splitters

Mechanical drop forged, hardened and tempered plated steel. Ideal for releasing seized/damaged nuts etc.



Product Number	Capacity (mm/Inch)	Weight each	Order Code
1	9 - 12 (3/8" - 1/2")	90g	-4090K
2	12 - 16 (1/2" - 5/8")	170g	-4160K
3	16 - 22 (5/8" - 7/8")	350g	-4220K
4	22 - 27 (7/8" - 1 1/16")	600g	-4270K

4 Piece Set

Contents (1 of each): No.1, No.2, No.3, No.4.

**4
PIECES**

 Group **582**

Weight each	Order Code
1.40kg	KEN-503
	-4290K

PRODUCTS ARE ONLY AVAILABLE VIA YOUR DISTRIBUTOR

KENNEDY Oil Drain Plug Key Set
QUALITY INDUSTRIAL TOOLING

DPK017

A comprehensive set of quality 3/8" sq. drive oil drain plug keys with tommy bar. Made from satin finished chrome vanadium.

Contents: Male Square: 7mm, 8mm (5/16"), 9mm (3/8"), 10mm, 11mm, 12mm and 13mm. Female Square: 10mm. Male Hex: 8, 9, 10, 12, 14 and 17mm. Male Triangular 10mm. Tommy bar.



**17
PIECES**

Product Number **KEN-503**
DPK017 **-1720K**

Three Jaw Oil Filter Wrench

For use with ratchet handles, extension bars, flexible drives etc. With 3/8" square drive and hexagon adaptor, or use with 19mm/3/4" AF spanners or sockets. All steel construction, chrome plated with milled teeth on gripping arms for positive action when loosening or tightening.



Spread/Range **KEN-503**
60 to 120mm **-1800K**
Weight each **600g**

SENATOR Oil Filter Wrench
QUALITY TOOLING

Articulated filter wrench with swivel action tightener. Suitable for oil filters with limited access.



Capacity **SEN-503**
75 to 110mm **-1800K**
Weight each **320g**

Strap Type Oil Filter Remover

Used for gripping round and irregular shaped items, tubes and piping. Ideal for oil filters, hot radiator caps and hub caps.



Diameter (mm) **KEN-582**
60 - 140 **-9500K**
Weight each **280g**

Chain Wrench Oil Filter Remover

Used for gripping round and irregular shaped items, tubes and piping. Ideal for oil filters, hot radiator caps and hub caps.



Diameter (mm) **KEN-582**
60 - 140 **-9520K**
Weight each **430g**

Oil Filter Pliers

Manufactured from hardened and tempered chrome vanadium with chemically blackened corrosion resistant finish and vinyl grip. Three position rapid jaw adjustment with high grip tooth profile, ensures the minimum amount of effort is required to remove or fit oil filters.



Size **KEN-503**
255mm (10") **-1760K**
305mm (12") **-1780K**
Capacity (mm) **69-80**

KENNEDY Parts Washer - Bench Standing
QUALITY INDUSTRIAL TOOLING

Used in garage, workshop and industrial applications for degreasing components for inspection and prior to assembly. Recirculated cleaning fluid is filtered before entering the pump and being directed over the workpiece. Flexible chrome finish metal delivery hose. Heavy duty non-welded one piece tank. Fully enclosed electric nylon pump. Self-latching fusible linked lid closes in the event of a fire. Triple baked enamel finish. Accepts all common degreasing agents. Shelf keeps parts out of solvent during inspection and drying. Immersion soaking when the parts shelf is removed. Fitted with a 3 pin moulded plug and a 1.6m power cable. Minimum agent capacity 9ltr. Maximum agent capacity 13ltr. Rubber feet. 240V.

Overall size (L x W x H): 470 x 340 x 250mm.
Tank size (L x W x H): 400 x 310 x 230mm.
Power rating: 25W.
Voltage: 240V.
Rated input: 0.3A.



Product Number	Weight each	Order Code
PWB013	6.50kg	-8600K

Parts Washer - Floor Standing

Used in garage, workshop and industrial applications for degreasing components for inspection and prior to assembly. Recirculated cleaning fluid is filtered before entering the pump and being directed over the workpiece. Flexible chrome finish metal delivery hose. Heavy-duty non-welded one-piece tank. Fully enclosed electric nylon pump. Self-latching fusible linked lid closes in the event of a fire. Triple baked enamel finish. Accepts all common degreasing agents. Shelf keeps parts out of solvent during inspection and drying. Immersion soaking when the parts shelf is removed. Fitted with a 3 pin moulded plug and a 1.6m power cable. Minimum agent capacity 40ltr. Maximum agent capacity 50ltr. Fitted with a drain plug for easy maintenance. Removable parts basket. Built-in replaceable filter. Spare filter included.

Overall size (L x W x H): 800 x 550 x 890mm.
Tank size (L x W x H): 725 x 490 x 270mm.
Height of working area: 750mm.
Power rating: 25W.
Voltage: 240V.
Rated input: 0.3A.



Model Number	Weight each	Order Code
PWF050	31.0kg	-8640K

Replacement Parts

Description	Order Code
	KEN-567
Flexible Hose for PWB013	-6050K
Flexible Hose for PWF050	-6060K
Filter for PWB013	-8600K
Filter for PWF050	-8640K
Pump for PWF050/PWB013	-8700K

PRODUCTS ARE ONLY AVAILABLE VIA YOUR DISTRIBUTOR

KENNEDY Mechanical
QUALITY INDUSTRIAL TOOLING **Bearing Pullers**

Industrial Reversible/Double-Ended Adjustable

Used for the removal of gears, ball races, bearings, pulleys and sprockets from a drive shaft. With reach capacities of 75, 100, 150 and 200mm.

All sizes have double-ended, adjustable, reversible legs and can be used for internal and external applications.

Selection

Always use a three jaw puller whenever possible. This produces better load distribution across the jaws and easier and safer removal of the part. Determine what 'spread' is needed - this is the width of the part to be removed. The reach capacity is determined by the depth of the part to be removed.

UP TO 175mm REACH

All pullers can be assembled for internal or external use.

3 Jaw Pullers - Supplied with both 3-legged yoke

Product Number	Spread (mm)	Reach (mm)	Thread Length	Order Code
MP375	40 - 75	60	125	-3130K
MP3100	50 - 100	70	160	-3140K
MP3200	60 - 150	120	240	-3160K
MP3150	80 - 200	175	335	-3180K

2 Jaw Pullers - Supplied with both 2-legged yoke

Product Number	Spread (mm)	Reach (mm)	Thread Length	Order Code
MP275	40 - 75	60	125	-3030K
MP2100	50 - 100	70	160	-3040K
MP2200	60 - 150	120	240	-3060K
MP2150	80 - 200	175	335	-3080K

Spare Puller Jaws

Supplied individually



To Suit Puller

Order Code
KEN-567

KEN-503-3030K/-3130K/-3230K	-5330K
KEN-503-3040K/-3140K/-3240K	-5340K
KEN-503-3060K/-3160K/-3260K	-5360K
KEN-503-3080K/-3180K/-3280K	-5380K

Extra Long Reach Mechanical Puller - 2 Jaw

Reversible

Manufactured from drop forged hardened alloy steel. Three position extra long legs to be used where access is limited. The puller legs are securely located on the bearing by screwing down the tapered nut to lock the arms in position. The legs are then retracted with the bearing by turning the T-bar to extend the thrust bolt on to fixed shaft.

Spread: 10 - 50mm.
Reach: 300mm.



EXTRA LONG

UP TO 300mm REACH

2 JAW

Reach	Weight each	Order Code
300mm	1.20kg	-3320K



Group
670



3 Jaw - Internal Assembly



3 Jaw - External Assembly



2 Jaw - Internal Assembly

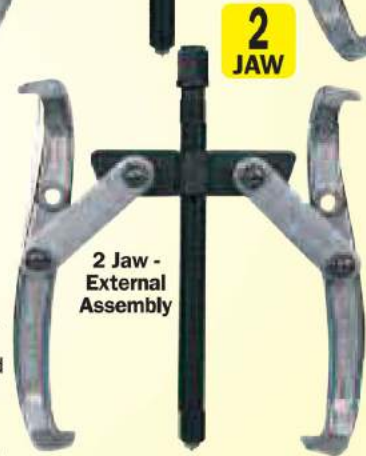

2 Jaw - External Assembly

Spare Jaws are also Available

Combined 2+3 Jaw Pullers - '4-in-1'

BEST SELLER Supplied with 2 and 3-legged yokes and 3 leg assemblies - allowing the pullers to be configured in 2 jaw internal / external or 3 jaw internal / external assemblies.

Product Number	Spread (mm)	Reach (mm)	Thread Length	Order Code
MP275	40 - 75	60	125	-3230K
MP2100	50 - 100	70	160	-3240K
MP2200	60 - 150	120	240	-3260K
MP2150	80 - 200	175	335	-3280K

Bearing Separators

For removing bearings, gears and bushes from shafts where access with a mechanical puller is restricted. Separators have tapered edge for insertion behind close fitting bearings, gears and bushes.



Jaw hardness: 42° - 45° HRC.

UP TO 150mm CAPACITY

Product Number	Capacity (mm)	Order Code
BS50	30 - 50	-4520K
BS75	50 - 75	-4540K
BS105	75 - 105	-4560K
BS150	105 - 150	-4580K

Mechanical Separator Set

30 - 75mm

For removing bearings, gears, sprockets and bushes. Metal storage case.

Contents:

- 1x 7" thrust bolt.
- 1x 30 - 50mm separator.
- 1x 50 - 75mm separator.
- 2x 80 and 100mm main rods.
- 2x 90 and 110mm extension rods.
- 1x beam.



8 PIECES

Product Number	Weight each	Order Code
MS12	4.95kg	-4750K



KENNEDY
QUALITY INDUSTRIAL TOOLING

Mechanical Puller Sets

SWP9 Steering Wheel

Suitable for GM, Ford and Chrysler vehicles. Also suitable for removing pulleys and fly wheels.

Contents:

- 1x yoke,
- 1x thrust bolt.
- 1x thrust cap.
- 2x 75mm screws (5/16" x 24 UNF).
- 2x 75mm screws (3/8" x 16 UNC).
- 2x 90mm screws (5/16" x 18 UNC).
- 1x plastic storage tray.

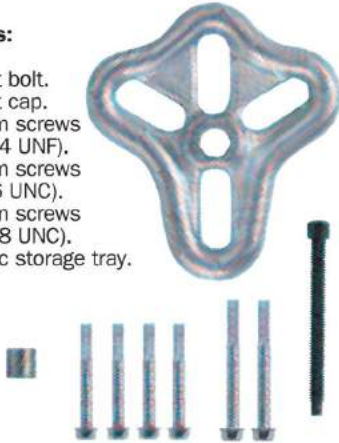

HPB9 Harmonic Balance

For harmonic balance removal, timing gears and other parts with bolt circle diameters from 38 to 117mm (1 1/2" to 4 5/8").

Ductile steel yoke.

Contents:

- 1x yoke.
- 1x thrust bolt.
- 1x ram nut.
- 3x 75mm screws (3/8" x 24 UNF).
- 3x 75mm screws (3/8" x 16 UNC).
- 1x plastic storage tray.



CP18 Combination

Steering wheel puller suitable for GM, Ford and Chrysler vehicles. For harmonic balance removal, timing gears and other parts with bolt circle diameters from 38 to 117mm (1 1/2" to 4 5/8").

Contents:

As SWP9 and HPB9 above.



Product Number	Weight each	Order Code
SWP9	1.00kg	-3400K
HPB9	1.80kg	-3420K
CP18	2.75kg	-3440K

AUTOMOTIVE - PULLERS & SEPARATORS

GROUP 503

Slide Hammer Puller Set

Multi-function

Fully hardened and chromed carbon steel slide hammer with a 1.2kg weight. Slide hammer design for removing bearings from blind housings. Suitable for use where a shaft or other solid surface is not available for a thrust bolt or hydraulic ram to push against. The bearing is removed by the impact action of the slide hammer weight hitting the stop at the end of the bar. The puller legs are securely located on the bearing by screwing down the tapered nut to lock the arms in position. Blow moulded storage case.

Contents:

- 1x T-bar.
- 1x hammer.
- 1x two jaw head.
- 1x three jaw head.
- 1x leg locking nut.
- 1x grip wrench adaptor.
- 1x tapping adaptor and hook.
- 2x axle pullers.
- 3x 120mm puller legs,
- 3x screw and nut assemblies.
- 1x blow moulded storage case.



Product Number	Weight each	Order Code
SHP8	8.20kg	-3480K

Slide Hammer Puller Set

3 Jaw Internal & External Multi-function

Fully hardened and chromed carbon steel slide hammer with a 1.2kg weight. Slide hammer design for removing bearings from blind housings. Suitable for use where a shaft or other solid surface is not available for a thrust bolt or hydraulic ram to push against. The bearing is removed by the impact action of the slide hammer weight hitting the stop at the end of the bar. The puller legs are securely located on the bearing by screwing down the tapered nut to lock the arms in position. Blow moulded case.

6 Piece Set Contents:

- 1x T-bar.
- 1x hammer 1.2kg.
- 1x 3 jaw internal puller 15 - 30mm.
- 1x 3 jaw internal puller 30 - 80mm.
- 1x 3 jaw external puller 15 - 80mm.
- 1x blow moulded case.



Product Number	Weight each	Order Code
IEP	4.95kg	-3340K



6 PIECES

3 JAW

15 PIECES

2&3 JAW

2 Jaw External

3 Jaw External

3 Jaw Internal

2 Jaw Internal

HAND TOOLS

PRODUCTS ARE ONLY AVAILABLE VIA YOUR DISTRIBUTOR



KENNEDY 6 Way Hydraulic Puller Set

10 ton capacity hydraulic ram with tommy bar. Supplied with three position puller legs covering a spread of 100 - 240mm and reach of 0 - 150mm. Can be used as a two or three legged puller with the same head.

Contents:

- 1x combination head.
- 1x hydraulic ram.
- 3x three position puller legs.
- 6x leg connectors.
- 6x screw nuts, bolts and washers.
- 1x 50mm extension rod.
- 1x centre adaptor.
- 1x blow moulded storage case.



2&3 JAW **250mm REACH**

Product Number	Weight each	Order Code
HP19	4.90kg	-3500K

Hydraulic Ram

10 ton capacity grease filled hydraulic ram with spring loaded plunger. Provides direct non-twisting application of thrust that is more effective and secure than a mechanical thrust screw. Fully threaded body allows for quick and easy height adjustment.

Capacity: 10 ton.

Length (excluding handle): 190mm.

Diameter of ram: 38mm.

Thread pitch: 16 gauge x 3/8" BSW



Product Number	Weight each	Order Code
HR10T	1.40kg	-7200K

Product Number	Order Code
Seal Repair Kit	-8230K

Hydraulic Separator Sets

HS7 105 - 150mm

HS11 75 - 105mm

For removing bearings, gears, sprockets and bushes. 10 ton capacity hydraulic ram with tommy bar. Metal storage case.

Both sets contain:

- 1x hydraulic ram.
- 1x separator.
- 2x 200mm main rods.
- 2x 230mm extension rods.
- 1x beam.
- 1x ram nut.
- HS7 (only) also contains
- 1x 80mm push plate.
- 1x 50mm ram extension.
- 1 x 100mm ram extension.

8 PIECES



HS7 Set Illustrated



Product Number	Weight each	Order Code
HS7	15.0kg	-4700K
HS11	9.30kg	-4720K

Hydraulic Puller/ Separator Set

10 ton capacity hydraulic ram with tommy bar. Suitable for agricultural machines, garage and industrial use.

Contents:

- 1x hydraulic ram (KEN- 503-7200K).
- 3x 4", 6" and 8" puller legs.
- 1x twin head.
- 1x triple head.
- 1x 50mm ram extension.
- 1x 100mm ram extension.
- 2x 200mm main rods.
- 2x 230mm extension rods.
- 1x 75 - 105mm separator.
- 1x bolt.
- 1x ram ring. 1x ram nut.
- Blow moulded storage case.



Product Number	Weight each	Order Code
HPS22	16.0kg	-3520K

KENNEDY Spring Compressor Sets
QUALITY INDUSTRIAL TOOLING

Hardened steel screws and cast steel claws.

2 Legged

Central hexagonal drive with wrap over coil claws which can be reversed for spreading applications. Suitable for use on cars and light commercial vehicles. Use with 21mm/13/16" AF open ended spanner.

Maximum jaw opening: 250mm.

3 Legged

Each leg has one free moving claw and one threaded claw with a 1/2" square drive or 24mm hexagon drive - can be used with air tools or spanners. Fitted with safety hooks to prevent accidental release. Suitable for use on cars and commercial vehicles and allows safe compression of heavier springs.

Maximum jaw opening: 240mm.



Product Number	Number of Legs	Weight each	Order Code
CCD225	2	1.20kg	-2410K
CCD324	3	3.00kg	-2420K

Ball Joint Separators

Manufactured from drop forged alloy steel with slim tapered fork jaw for easier access into confined areas. Suitable for use on most car and light commercial vehicle ball joints.

100mm Overall Length - Restricted Access

Designed for use in hard to reach and confined areas. Mainly for use on Asian import cars.

100mm overall length



160mm overall length

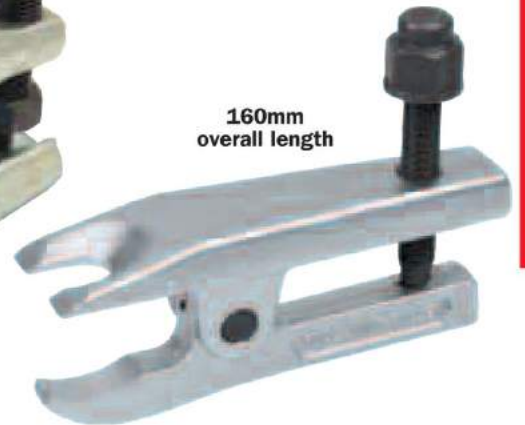

Overall Length	Capacity	Throat Depth	Throat Width	Weight each	Order Code
100mm	22mm	22mm	22mm	740g	-1400K
160mm	45mm	22mm	18mm	1120g	-4400K

Ball Joint Servicing Kit

Made from cast iron and hardened carbon steel, this kit is designed for the removal of press fit type ball joints without having to remove the control arm from the vehicle. The kit can also be used for removing brake anchor pins and the servicing of universal joint bearings.

Weight each
7.60kg

Order Code
KEN-503
-1300K



PRODUCTS ARE ONLY AVAILABLE VIA YOUR DISTRIBUTOR



**4000kg Elasticated
Tow Rope**

Model TRE400

Two zinc plated steel safety hooks. Elasticated core minimises drag on overrun. Heavy duty stitched webbing. On tow sign. Manufactured to **BS AU 187 1983**.

Extended length: 4m.

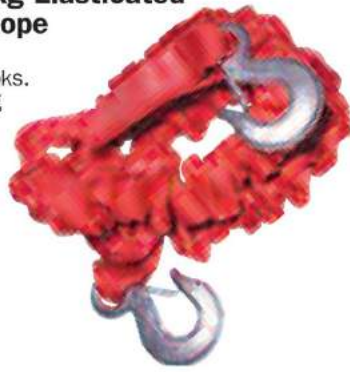

Order Code
KEN-503

-8240K

2000kg Tow Rope

Model TRP200

Zinc plated steel safety hook. Looped one end. Manufactured from tough high visibility polypropylene. On tow sign. Manufactured to **BS AU 187 1983**.

Length: 3.6m.



Order Code
KEN-503

-8220K



**Telescopic
Wheel Wrench**

Manufactured from drop forged chrome vanadium steel. Supplied with 17/19mm double ended socket that will fit the majority of car wheel nuts. Can be used with any other 1/2" drive accessories. Extends to 500mm overall to give maximum leverage. **GS and TUV approved.**



Drive

Weight
each

Order Code
SEN-503

1/2"

1.00kg

-9000K

Fluorescent Warning Triangle

Manufactured from ABS plastic. This simple folding design combines a sturdy four footed base with its rubber grip feet and a high visibility interlocking triangle conforming to European Standard **ECE R27** and tested to **E1** specifications. Supplied in a low profile plastic carrying case.

Triangle dimensions:

440mm (each side).

Triangle height: 380mm.



Order Code
KEN-503

-8400K

Steel Jerry Cans

Manufactured from 16 swg steel. Suitable for storing petrol. Suitable for storing and transportation of diesel, paraffin and motor oil. With lever type safety sealing cap and integral carrying handle. Painted outside and phosphated internally. **UN Approved, Class 3.**



Capacity

Order Code
KEN-503

5ltr

-9270K

10ltr

-9260K

20ltr

-9250K

Metal Spouts For Jerry Can

Capacity

Order Code
KEN-503

5 & 10ltr

-9300K

20ltr

-9320K

5ltr Fuel Container

Suitable for transporting and storage of petroleum spirit and diesel. UN approved, conforms with **S.I. 1982/630 Petroleum Spirit Plastic Container Regulations 1982**. Colour coded for use with different fuel types.



Colour

Weight
each

Order Code
KEN-503

Red

630g

-9010K

Green

630g

-9020K

Black

630g

-9030K

Non-Approved Fuel Container

Durable polyethylene containers. Diesel, petrol, chemical and oil resistant. Integral rigid dispensing spout.



Capacity

Weight
each

Order Code
KEN-503

5ltr

320g

-9100K

10ltr

500g

-9120K

20ltr

755g

-9140K

Steel Fuel Can

Manufactured from heavy gauge steel with an epoxy coated finish. Supplied with a flexible polythene vented pouring spout. Suitable for storage and transportation of petroleum spirit. Tested to **DIN 7274**, complies with **UN Class 3**.



Capacity

Weight
each

Order Code
KEN-503

10ltr

1.90kg

-9200K

KENNEDY **Mini Air Compressor/
Pressure Gauge/Tyre Inflator**

For inflating tyres, airbeds, boats, sports equipment and any other inflatable products. Complete with 3m of cable 12V car cigarette lighter plug, nozzles and adaptors. The dual air pressure gauge can be read in both lb/in² and kg/cm². 300psi.



Voltage	Weight each	Order Code
12	1.3kg	KEN-503 -2500K

SENATOR **Single Cylinder
Foot Pump**

Steel barrel, preset pressure gauge, rubber foot-rest pad. Standard thumb-lock connector. 24" hose length.

Capacity: 0 - 7bar/0 - 7kgf cm² (100psi).



Weight each	Order Code
1.1kg	SEN-503 -5350K

KENNEDY **Pencil Type Tyre
Pressure Gauge**

This push-on gauge is suitable for cars, vans and light commercials. It is of chrome plated brass construction with a pen type pocket clip.



Max. Pressure Reading	Weight each	Order Code
120psi	43g	KEN-503 -8460K

Tyre Tread Depth Gauge

This handy sized tyre depth gauge is graduated in mm and 1/32" and comes with a pen type pocket clip.



Weight each	Order Code
25g	KEN-503 -8450K

AUTOMOTIVE - TYRE CARE
Air Line Tyre Inflator

This push on type tyre inflator is robust and is protected from accidental damage by a rubber shock guard.



Max. Pressure Reading	Weight each	Order Code
170psi	720g	KEN-503 -8480K

**Heavy Duty Air Line
Tyre Inflator with Gauge**

This heavy duty push on inflator is of rugged construction and has a clear view integral pressure gauge reading from 10 - 120psi.



Max. Pressure Reading	Weight each	Order Code
120psi	635g	KEN-503 -8520K

Deluxe Type Tyre Pressure Gauge

Manufacturer's recommended pressures are based on cold tyre readings. This pressure gauge has a long body, ideal for use on cars, vans, lorries, plant and equipment.



Max. Pressure Reading	Weight each	Order Code
120psi	230g	KEN-503 -8430K

Dial Type Tyre Pressure Gauges

This push-on type pressure gauge is graduated in psi and bar up to a maximum of 64psi (4.5bar). The reading is held until the release button is pressed.



Max. Pressure Reading	Weight each	Order Code
64psi	125g	KEN-503 -8440K

4-Way Tyre Valve Service Tool

This case hardened tool is for the internal and external repair of valve threads, insertion and removal of valve cores.



Order Code
KEN-503 -8500K

GROUP
503

AUTOMOTIVE - SPECIAL TOOLS

KENNEDY Cleaning & Decarbonising
Brush Set

20-Piece

This cleaning brush set is very versatile in use as it comes with three different material bristles and can be used either manually or with a power drill.

Contents:

Quick release screwdriver, quick release extension bar,
9, 11, 13, 15, 17 & 19mm Ø Brass Brushes,
9, 11, 13, 15, 17 & 19mm Ø Steel Brushes,
9, 11, 13, 15, 17 & 19mm Ø Nylon Brushes.

**20
PIECES**



Order Code
KEN-503
-4990K



Spark Plug Brush Set

Set of three: nylon, brass and stainless steel.



**3
PIECES**

Order Code
KEN-503
-5000K

Spark Plug Hole Thread Chaser

Double ended for 14mm and 18mm plug hole threads. Cleans corrosion and carbon build-up from female spark plug threads and sensor sockets. Repairs minor cross threading damage. Use with 21mm deep socket.



Order Code
KEN-503
-2750K

HAND TOOLS

Standard Length Gasket Scraper Set

Rigid carbon scrapers ideal for cleaning cylinder heads, removing old sealants, carbon build up and a variety of general multi-purpose automotive applications.

**4
PIECES**

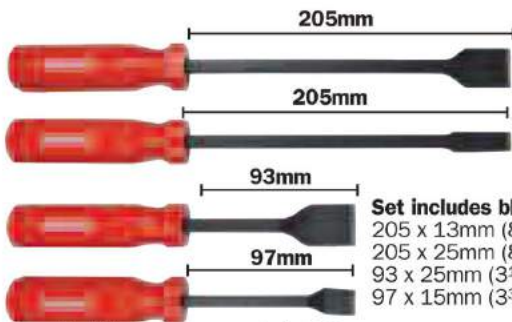

Set includes blade lengths:
205 x 13mm (8" x 1/2"),
205 x 25mm (8" x 1"),
93 x 25mm (3 1/2" x 1"),
97 x 15mm (3 3/4" x 5/8").

Weight each
1.10kg
Order Code
KEN-503
-1980K

Gasket Scraper Set

For cleaning cylinder heads and removing old sealants and carbon build up. Hardened and tempered carbon steel shanks and heads are 'offset to edge' to allow easy scraping of flat surfaces. Simple 'firmer' style bevelled points with longer head lengths allow for scrapers to be re-ground several times for maximum service life. Impact resistant square section handle for secure grip even when greasy. Set includes blade widths: 19mm (3/4"), 25mm (1") and 38mm (1 1/2").

Overall length: 280mm (11").

**3
PIECES**

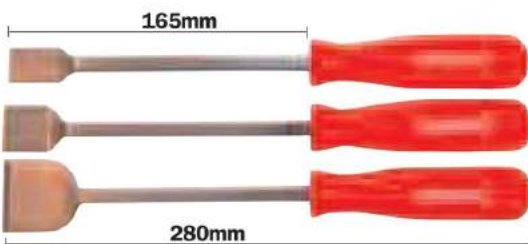

Product Number
GSL338
Weight each
530g
Order Code
KEN-503
-1700K

Glow Plug Socket Set

GPS060

A comprehensive set of quality glow plug sockets with universal joints for use in awkward areas. Made from satin finished chrome vanadium with a neoprene insert to grip and protect the plug.

Contents: 8, 9, 10, 12, 14 and 16mm.

**6
PIECES**



Product Number
GPS060
Order Code
KEN-503
-1740K

Professional Glow Plug Connector Pliers

Suitable for the removal of hard to reach glow plug connectors found on the latest generation of engines. Made from chrome vanadium steel. Composite handle provides added comfort and control.

Blade length: 125mm.

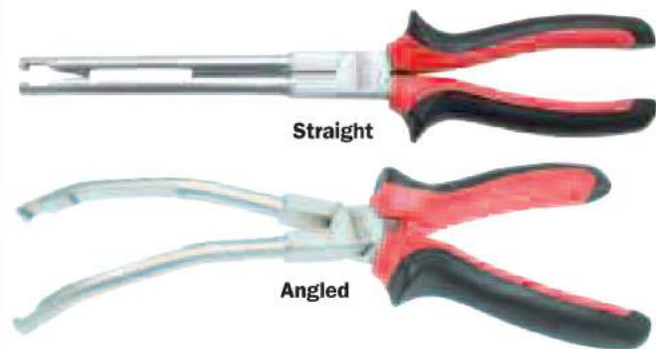

Jaw Type
Straight
Angled
Order Code
KEN-503
-1240K
-1260K



KENNEDY
QUALITY INDUSTRIAL TOOLS

Oxygen 'EGO', 'O2', 'Lambda' Sensor Socket Set

Three piece universal set. Essential for servicing today's computer-controlled vehicle systems. Easily removes exhaust gas oxygen sensors (known as 'EGO', 'O2' or 'Lambda' sensors), vacuum switches and pressure switches. Also suitable for diesel injectors found on Mitsubishi, Nissan, Opel, Vauxhall and VW vehicles. Made from heat treated cast steel.

AUTOMOTIVE - SPECIAL TOOLS

GROUP
503



3
PIECES



Set contains:

22mm (7/8") hex, 1/2" square drive socket with 7.5mm side slot for sensor wire clearance.
Socket has 22mm hex for use with a spanner. **Overall length: 80mm.**
22mm (7/8") hex, crow's foot style wrench, 1/2" square drive (double square for easy access).
With full length 11mm slot for total clearance of switch/sensor wire.
22mm (7/8") hex, crow's foot style wrench, 3/8" square drive.
With full length 8.6mm slot for total clearance of switch/sensor wire.

Order Code
KEN-503
-8020K

Rear Axle Bush Installation Tool

For the in-situ installation of the rear axle mounting bushes on selected VW and Audi vehicles such as Audi A3, VW Bora and Golf IV.



Order Code
KEN-503
-1550K

Oxygen Sensor Socket

1/2" square drive. 22mm hex. x 90mm length. Cutaway section allows socket to pass over wiring.



Order Code
KEN-503
-2760K

Viscous Hub Spanners

For the removal of thermal viscous fan hubs. Suitable for most makes of car.



Size (mm)	Weight each	Order Code
32	325g	-1850K
36	315g	-1860K

Diesel Injection Pump Puller

For the removal of diesel injection pumps from the following engines:

DPP010



DPP020



Product Number	Suitable for the following engines	Order Code KEN-503
DPP010	Landrover Freelander (Td4) & Rover 75 2.0d (M47R)	-1620K
DPP020	BMW M47/57 Engines	-1630K

Diesel Injector Removal Set Bosch/Delphi

Specifically designed for removing Delphi/Bosch injectors using 5/8" slide hammer. Set of three adaptors and a special tool for removing the internal part of Bosch injectors which can be used with an air tool to loosen the injectors through vibration.

4
PIECES



Order Code
KEN-503
-1820K

Diesel Injector Seat Cutter Set

Specifically designed for the cleaning and recutting of injector seats. For use with Bosch, Delphi, Iveco, Fiat and other universal applications.

Includes: five cutting reamers, pilot post, T-bar and a hexagon key.

8
PIECES



Order Code
KEN-503
-1830K

HAND TOOLS

PRODUCTS ARE ONLY AVAILABLE VIA YOUR DISTRIBUTOR

359

© 2018

KENNEDY Exhaust Doughnut Puller
QUALITY INDUSTRIAL TOOLING

To enable fast installation or removal of rubber anti-vibration mounting rings found on modern exhaust systems. Puller has offset hook for easier application and dipped vinyl handle for added comfort and extra grip. Manufactured from hardened steel.

Length: 290mm.



Product Number	Weight each	Order Code
EPD290	225g	KEN-503 -1600K

Magnetic Wing Cover

Designed to be used in the workshop to protect car wings when working. Manufactured from heavy duty vinyl with a soft backing to prevent any scratching or marking of paintwork when in use. The cover is held in place by magnets stitched into the material. Folds to a quarter of its length for storing.

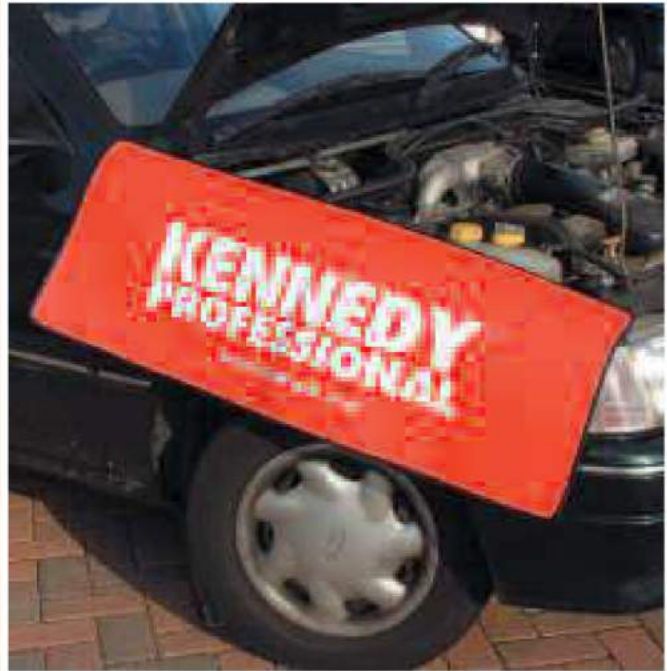

Size (mm)	Weight each	Order Code
1100 x 400	810g	KEN-503 -7800K

HAND TOOLS

Seal Puller Tool

Two size tips allow you to remove oil or grease seals from virtually anything including wheel bearings, transmission housings, etc. Hardened and tempered carbon steel shank and head with oxidised finish tips, chrome plated shank for protection against corrosion. Impact resistant square section handle for secure grip even when greasy.

Overall length: 310mm (12¼").



Model Number	Weight each	Order Code
SPT312	365g	KEN-503 -2900K

T-Handle Circlip® Tool

Fully adjustable internal and external Circlip® tool. Manufactured from hardened steel fitted with T-handle to give smooth precise control. Supplied with .090", .118", 0.150" and .170" interchangeable tips. 44 - 178mm capacity, ideal for use on commercial vehicles.



Product Length	Order Code
310mm	KEN-503 -4980K

Spare Tips

Tip Size	Order Code
0.090	KEN-567 -9100K
0.118	-9110K
0.150	-9120K
0.170	-9130K

Anti-Freeze Tester

Suitable for use with Ethylene Glycol or Methanol type anti-freezes. Shows lowest temperature at which the cooling system is protected against freezing. Tough glass tube construction with an easy to read scale. For use on hot or cold engines.



Product Number	Weight each	Order Code
AFT001	140g	KEN-503 -1100K

KENNEDY Cold Chisels -
QUALITY INDUSTRIAL TOOLING Chrome Vanadium

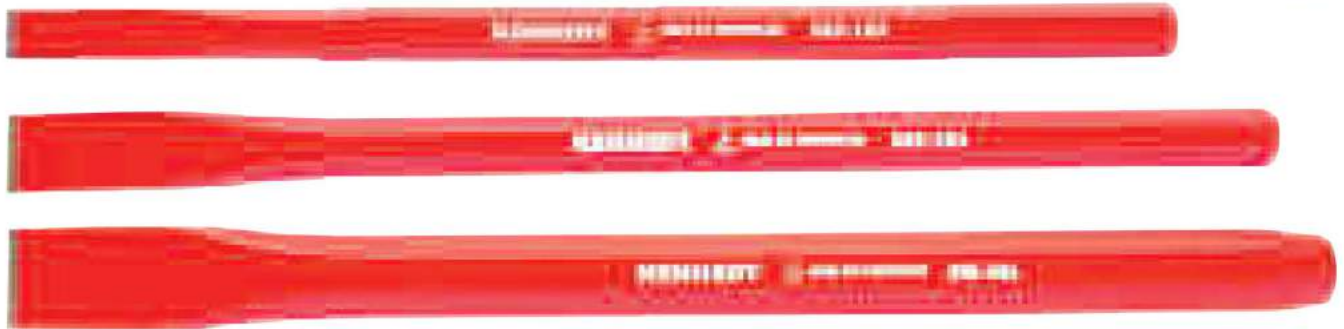
COLD CHISELS & PRY BARS

Manufactured from high quality octagonal chrome vanadium steel with a ground cutting edge. For use on brickwork, masonry and cold metals. Manufactured to **ASME B107.47M-1998**.

Flat
 Used for cutting and chipping cold metals and brickwork.

Flat Chisel Set

Number of Pieces	Contents (mm)	Order Code KEN-505
3	6 x 150, 12 x 200 & 18 x 255	-7150K
3	12 x 150, 18 x 200 & 25 x 255	-7160K

Brick Bolster - Chrome Vanadium

Used for splitting bricks.



Width x Length (mm)	Octagon (mm)	Order Code KEN-505
75 x 240	22	-7030K
100 x 240	22	-7040K

Flooring - Chrome Vanadium

Used for prising floorboards and cutting part of the board prior to lifting.



Width x Length (mm)	Octagon (mm)	Order Code KEN-505
56 x 230	16	-7120K

Pitching - Chrome Vanadium

For removing excess stone and facing, bevelled on one side.



Width x Length (mm)	Octagon (mm)	Order Code KEN-505
50 x 212	18	-6920K
62 x 212	22	-6930K

Width x Length (mm)	Octagon (mm)	Order Code KEN-505
6 x 100	6	-1600K
6 x 150	6	-1620K
9 x 125	6	-2410K
9 x 150	9	-2460K
12 x 150	9	-3220K
12 x 200	9	-3240K
12 x 255	9	-3260K
12 x 305	9	-3280K
16 x 150	12	-4020K
16 x 200	12	-4040K
18 x 200	16	-4840K
18 x 230	16	-4850K
18 x 255	16	-4860K
18 x 305	16	-4870K
18 x 455	16	-4890K
25 x 200	22	-6440K
25 x 230	22	-6450K
25 x 255	22	-6460K
25 x 305	22	-6470K
25 x 355	22	-6480K
25 x 455	22	-6490K

Half Round - Chrome Vanadium

Used for channelling concrete floors.



Width x Length (mm)	Octagon (mm)	Order Code KEN-505
6 x 150	12	-6620K
18 x 200	18	-6640K

Cross Cut - Chrome Vanadium

Used for channelling brickwork.



Width x Length (mm)	Octagon (mm)	Order Code KEN-505
6 x 150	12	-6720K
9 x 200	18	-6740K

Diamond Point - Chrome Vanadium

Used for channelling brickwork.



Width x Length (mm)	Octagon (mm)	Order Code KEN-505
8 x 200	18	-6840K

Plugging - Chrome Vanadium

For removing cement mortar from between bricks.



Width x Length (mm)	Octagon (mm)	Order Code KEN-505
5 x 255	16	-7100K

PRODUCTS ARE ONLY AVAILABLE VIA YOUR DISTRIBUTOR

GROUP 505 COLD CHISELS & PRY BARS

KENNEDY Heavy Duty Pry Bars
QUALITY INDUSTRIAL TOOLS

Manufactured from forged carbon heat treated steel with ground points. These traditional designs are ideal for use by tradesmen in any industrial environment.

Rolling Head
Suitable for use in confined spaces.

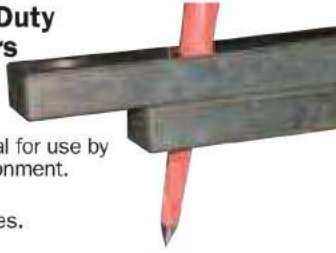

Length x Width	Order Code
150 x 10mm	-8400K
300 x 13mm	-8420K
450 x 16mm	-8440K

Line Type
Angled blade provides greater leverage.

Length x Section	Order Code
400 x 16mm	-8520K
600 x 20mm	-8560K

Rolling Head Set

Contents	Order Code
150mm Rolling head 300mm Rolling head 450mm Rolling head	-8780K

**3
PIECES**

Line Type Set

Contents	Order Code
400mm Line Type 600mm Line Type	-8770K

**2
PIECES**

HAND TOOLS

YAMOTO Chisel & Punch Set

**14
PIECES**

Chrome Vanadium Steel

Contents:
Pin punches: 3/16" x 6", 3/32" x 4 1/4", 1/8" x 4 3/4", 3/16" x 5 1/4" and 1/4" x 5 3/4".
Centre punches: 5/32" x 5".
Chisels: 1/2" x 6", 5/8" x 6 1/2", 3/4" x 7 1/2" and 7/8" x 8".
Taper punches: 3/16" x 10", 7/32" x 10", 5/16" x 10" and 3/8" x 10".



Order Code
YMT-505
-9010K

Plastic Handled Pry Bars

Made from square section chrome vanadium with ground points. Impact resistant plastic handles offer a more comfortable and secure grip to make these pry bars user friendly. Handles are oil and acid resistant. Suitable for a wide range of general duty applications within the packing, automotive, maintenance and assembly industries.

Straight Blade
For general duty usage.



Blade Length x Width	Order Code
300 x 10mm	-8300K
450 x 13mm	-8320K

Curved Blade
The curved blade provides greater leverage.

Blade Length x Width	Order Code
300 x 10mm	-8340K
450 x 13mm	-8360K
600 x 13mm	-8380K

Sets

Number of Pieces	Contents	Order Code
3	300mm Straight 300mm Curved 450mm Curved	-8330K
2	450mm Curved 600mm Curved	-8390K

Spot Weld Chisel & Bar

The Right Angled Seam Chisel and L Bar has been specially designed by Kennedy Tools for the separation of hard to reach spot welds and bonded panels as well as coping with the many traditional uses for pry and wrecking bars.

Features & benefits

- Easily separates hard-to-reach spot welded or bonded panels.
- Sharpened on three edges, the sharp end allows for penetration between the panels and both side edges allow for side impact to drive the panels apart without damage.
- 90° end for use in hard-to-reach pinchweld areas.
- Made from a super tough alloy steel.
- Will save the technician up to 15 minutes per panel replacement.

The Right Angled Rascal Bar with three sharpened edges is designed to allow two-directional hammer use on quarter panels, rockers and any other pinchweld. The sharp end allows for penetration between the panels and the two lower edges allows for side impact to drive the panels apart. The chisel tip can be used for starting seam separation.



Order Code
KEN-505
-1200K

Contractor Flat Cold Chisels

Manufactured from high quality octagonal chrome vanadium steel with a ground cutting edge, in accordance with BS 3066. For use on brickwork, masonry and cold metals.



Width x Length (mm)	Octagon (mm)	Order Code
12 x 200	11	-1060K
12 x 200 c/w guard		-1070K
18 x 200		-1100K
18 x 200 c/w guard	16	-1110K
18 x 255		-1120K
18 x 255 c/w guard		-1130K
25 x 200	22	-1160K
25 x 200 c/w guard		-1170K
25 x 255		-1180K
25 x 255 c/w guard	22	-1190K
25 x 305		-1200K
25 x 305 c/w guard		-1210K

Contractor Cross Cut Chisel

Chrome vanadium - used for channelling brickwork.



Width x Length (mm)	Octagon (mm)	Order Code
6 x 150	12	-1260K

Contractor Brick Bolster Chisels

Chrome vanadium - used for splitting bricks.



Width x Length (mm)	Octagon (mm)	Order Code
75 x 230	22	-1300K
75 x 230 c/w guard		-1310K
100 x 230	22	-1320K
100 x 230 c/w guard		-1330K

Contractor Electrician's Floor Chisels

Chrome vanadium - hardened and tempered cutting edge. For cutting the tongue in tongued and grooved floorboards.



Width x Length (mm)	Octagon (mm)	Order Code
55 x 230	16	-1360K
55 x 230 c/w guard		-1370K

Electric Engraver Kit

Electric hand held engraver with positive on/off switch and 5 position stroke adjuster for varied engraving depths. For use on metals, plastics, glass, ceramics, wood and leather. Supplied with two Carbide steel engraving tips and an alphanumeric template.

- 5-Position adjustable engraving depth
- Soft grip
- Positive On/Off
- 1.8m cable
- Includes 2 tips and template for letters and numbers



Product Number	Voltage	RPM	Weight each	Order Code
ENG003	2300	6000	375g	-9810K

COLD CHISELS & PRY BARS

GROUP 505

KENNEDY Wrecking & Pry Bars

Manufactured from heat treated carbon steel. Ideal for dismantling timber constructions, opening packing cases and removing nails (depending on the type of bar).

Chisel and V-Notch Wrecking Bar

For general dismantling and stripping applications, within a wide range of industries.

Length	Order Code
450mm	-7180K
600mm	-7240K
750mm	-7300K

Chisel and Point Crowbar For heavy duty work.

Length x Width	Order Code
900 x 38mm	-7360K
1200 x 42mm	-7480K
1500 x 42mm	-7600K

Heel and Point Crowbar For heavy duty dismantling.

Length x Width	Order Code
900 x 38mm	-7690K
1180 x 42mm	-7720K
1500 x 45mm	-7750K

Super Lever Pry Bars Can be used as a nail lifter, pry bar, adze or lever.

Length x Width	Order Code
325 x 33mm	-8200K
375 x 33mm	-8250K

Combination Sets Contains one wrecking bar and one pry bar.

Number of Pieces	Contents	Order Code
2	450mm Wrecking Bar, 325mm Pry Bar	-8750K
2	600mm Wrecking Bar, 375mm Pry Bar	-8760K

Scutch Holders - Carbon Steel

Used for chasing out and general masonry work.

Width x Length (mm)	Octagon (mm)	Order Code
25 x 200	18	-6860K
38 x 200	18	-6870K

Detachable Bit

For scutch chisels and hammers.

Comb Type	Width (mm)	Order Code
Wide/Coarse	25	-9130K
	38	-9140K
Plain/Drove	25	-9230K
	38	-9240K

Protector Sleeves

Contoured high impact resistant plastic grips redirects the force of miss-hits safely away from your hands preventing injury. Suitable for use with octagonal cold chisels.

To Suit Octagon Size	Length (mm)	Order Code
13mm	120	-9040K
16mm	120	-9050K
19mm	120	-9060K
22mm	120	-9070K



PRODUCTS ARE ONLY AVAILABLE VIA YOUR DISTRIBUTOR



KENNEDY PROFESSIONAL Box Section Spirit Levels

Extruded aluminium body. Powder coated finish. Three high visibility vials: horizontal, plumb and 45°. Two rubberised handle grips and two milled working faces.
Accuracy: 0.5mm/m.



Length (mm)	Number of Vials	Order Code KEN-510
300 (12")	3	-3300K
600 (24")	3	-3360K
800 (32")	3	-3380K
1000 (40")	3	-3400K
1200 (46")	3	-3420K
1800 (72")	3	-3480K

Torpedo Level

Professional - with two factory set horizontal and angled vials which are shockproof to a tolerance of 1mm/m. Die cast zinc body with enamelled finish. V-groove on base.



Length	Weight each	Order Code KEN-510
230mm/9"	140g	-0090K

KENNEDY QUALITY INDUSTRIAL TOOLING I-Beam Spirit Levels

Lightweight aluminium body with powder coat finish. 1 horizontal, 2 plumb vials. Shock absorbing end caps. Milled working faces for precise measurement. Beam structure makes it strong and durable. Rule scale for ease of marking out.

Accuracy: 1.0mm/m



Length (mm)	Number of Vials	Order Code KEN-510
300 (12")	3	-3620K
400 (16")	3	-3660K
600 (24")	3	-3740K
900 (36")	3	-3860K
1000 (40")	3	-3900K
12600 (48")	3	-3980K

Box Profile Spirit Levels

Lightweight aluminium body with powder coat finish. 1 horizontal, 2 plumb vials. Shock absorbing end caps. Milled working faces for precise measurement.

Accuracy: 0.75mm/m



Length (mm)	Number of Vials	Order Code KEN-510
600 (24")	3	-4240K
900 (36")	3	-4360K
1000 (40")	3	-4400K
1200 (48")	3	-4480K
15000 (60")	3	-4600K

SENATOR QUALITY TOOLING Torpedo Level

With magnetic base. Made from impact resistant ABS plastic. Three vials horizontal, vertical and 45°.

Accuracy: ±1.0mm/m.



Length (mm)	Weight each	Order Code SEN-510
230 (9")	140g	-2090K

ABS Plastic Girder Section Level

Manufactured from impact resistant ABS plastic. Three vials horizontal, vertical and 45°. Metric and Inch graduated face.

Accuracy: 1mm/1000mm.



Length (mm)	Number of Vials	Weight each	Order Code SEN-510
610 (24")	3	290g	-2240K

KENNEDY QUALITY INDUSTRIAL TOOLING Digital Protractor

PDV30
This digital protractor has a range of 360° split into 4 x 90° quadrants. It is simple to calibrate and the intelligent display changes orientation at 90° and 270° to remain readable. It has a 'V' groove on the top and bottom for easy placement on acute angled or cylindrical objects. 3V lithium battery gives up to 2000 hours use. Complete with a leatherette pouch that has a belt loop.



Range	Resolution	Order Code KEN-331
360° (90° x 4)	0.1°	-4020K

Boat Levels

Construction Boat Level
Die-cast aluminium frame with a milled measuring face for accuracy. 1 vertical, 1 horizontal vial for normal and upside down measuring. A very popular level with scaffolders. Includes leather belt pouch.

Accuracy: 1.0mm/m.



Base Type	Length (mm)	Order Code KEN-510
Non-magnetic	250 (10")	-0100K
Magnetic	250 (10")	-0160K

KENNEDY QUALITY INDUSTRIAL TOOLING Line Level

This durable line level is made hard wearing plastic. With reversed line hooks for a positive hold and a pocket clip. 13mm (1/2") wide.



Length	Weight each	Order Code KEN-510
75mm (3")	45g	-2400K

Magnetic Post Levels

Made from hard wearing plastic this specialist level designed to ensure both square and round posts are upright prior to permanent fixing. The right angle plate has two horizontal vials and one vertical vial with flush magnets for metal posts and an integrated elastic fixing strap for other materials.

Accuracy: ±1.0mm/m.



Overall Size	Weight each	Order Code KEN-510
75 x 125mm	87g	-2800K
85 x 140mm	87g	-2820K

Bullseye Level

Made from tough hard wearing plastic. Can be free standing, or fixed onto a surface. The all purpose Bullseye circular level will show level of any surface in all directions at once.

Height: 16mm.



Base Dia.	Level Dia.	Order Code KEN-510
50mm	32mm	-2100K

new

new



KENNEDY
QUALITY INDUSTRIAL TOOLING

Extending Support Prop

This lightweight support prop is designed to give a helping hand when fixing overhead panelling and boarding. It has 125 x 80mm flat plates at both ends with a swivel ball joint for ease of use and to avoid damage to panel when pressure is applied. It has four pre-set adjustable height ranges: 1.16 to 2m, 1.46 to 2.3m, 1.76 to 2.6m, 2.06 to 2.9m.



Range	Order Code
1.6 - 2.9m	KEN-512

15ltr Invincible Yellow Builder's Bucket

15ltr (3 gal.) filling scale inside. Five year guarantee.



Order Code
KEN-907
-8300K



RUTLAND Flexible Buckets
CONTRACTORS TOOLS

Extremely versatile and virtually indestructible. It can be used for moving soil, garden waste, rubble and various other jobs around a garden or building site. 460mm diameter.



Size	Weight each	Order Code
42ltr	200g	RTL-523 -4880K

SITESAFE

Builder's Flexible Bucket

Extremely versatile and virtually indestructible. It can be used for mixing plaster or cement, moving rubble and various other jobs around a building site.



Size	Order Code
	SSF-512
Yellow Buckets	
26ltr	-2980K
40ltr	-3000K
75ltr	-3040K
Blue Buckets	
26ltr	-3080K
42ltr	-3100K

PLASTERING TOOLS

GROUP
512

KENNEDY
PROFESSIONAL

Paint & Plaster Mixer

Used for mixing plaster, concrete, filler, epoxy resin, emulsion paint and wallpaper paste. The stirring end should be fully immersed before the shaft is turned.

Light duty shaft 8mm hex.
Overall length: 400mm.
Heavy duty shaft: 12mm hex.
Overall length: 600mm.



Shaft	Weight per 10	Order Code
Light Duty	680g	-2780K
Heavy Duty	860g	-2800K

KENNEDY Builder's Buckets
QUALITY INDUSTRIAL TOOLING

Capacity: 13.5ltr (3gal.)
Plastic: medium 'V' lip.
Rubatype: Large 'V' lip. All rubber.



Plastic



Rubatype

Type	Weight each	Order Code
Plastic	0.55kg	-8030K
Rubatype	2.10kg	-8130K

HAND TOOLS

PRODUCTS ARE ONLY AVAILABLE VIA YOUR DISTRIBUTOR

© 2018



Plasterer's Hawk

Lightweight scoured aluminium blade to prevent plaster 'slip-off'. Detachable wooden handle with cushioned comfort ring. Designed to reduce discomfort during periods of extended use. Manufactured to the high standards expected by today's trade.



Plasterer's Hawk

With single screw fixing, zinc plated for corrosion protection. Heavy gauge sheet aluminium platform, highly polished, mirror finish. Suitable for DIY use.



Size (mm)	Weight per 10	Order Code
300 x 300	7.00kg	KEN-512 -0920K

Size (mm)	Weight per 10	Order Code
265 x 265	6.20kg	SEN-512 -0920K

HAND TOOLS



Plasterer's Trowel

Aluminium shank single tang banana pattern. Six rivet construction 'cross ground' to prevent drag. For laying on and finishing plaster. Manufactured to the high standards expected by today's trade.



Plasterer's Trowel

Economy
Single tang, banana shaped handle with six concealed welded rivets to securely fix 'cross ground', hardened and tempered blade.



Adhesive Trowel

High quality moulded and contoured handle. Large base with two coarse pitched edges and two fine pitched edges. Suitable for use with all tile and carpet adhesives.



Size	Weight per 10	Order Code
280mm (11")	4.00kg	KEN-512 -0100K

Size	Weight per 10	Order Code
280mm (11")	4.60kg	SEN-512 -0100K

Size (mm)	Weight per 10	Order Code
270 x 110	190g	KEN-512 -0400K



Plasterboard Tape

White self-adhesive plasterboard fibreglass tape for fast application with a strong bond. Won't tear, stretch, shrink or bubble, and helps prevent cracks in plaster finishes.



Width x Length	Order Code
50mm x 90m	AVN-981 -0130K



Wooden Skimming Float

Manufactured from selected timber. Ideal for producing a sandy surface finish when rendering plaster or concrete.

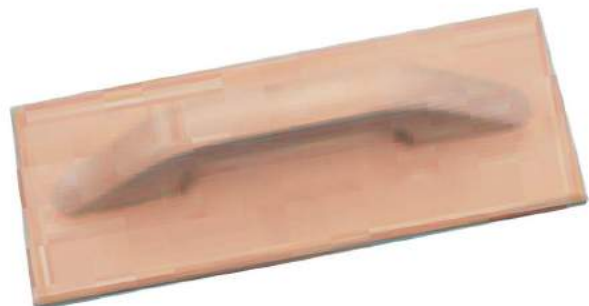

Size (mm)	Weight per 10	Order Code
290 x 100	190g	KEN-512 -0950K

Double Ended Brick Jointer

Heavy duty steel. Used to produce 1/2" and 5/8" concave joints between bricks.



Overall Length (mm)	Order Code
580	KEN-512 -0440K

Brick Jointer

Suitable for half round finishing of the joints between bricks. London pattern smooth wooden handle with integral tang.



Size (mm)	Weight per 10	Order Code
150 x 12	1.50kg	KEN-512 -0420K

Plumb Bobs

Corrosive resistant epoxy coated with brass screw cap. For establishing vertical datum line without the use of a level.



Weight each	Order Code
5oz	KEN-512 -2050K
10oz	-2100K

Line Pins

Construction quality, hand, chrome plated line pins. Supplied in pairs. Use with Kennedy brick line to create a horizontal line for consistent bricklaying.



Size	Weight per 10	Order Code
150mm (6")	140g	KEN-512 -2160K

Brick Line

Construction quality, use with line pins and plumb bobs.



Size	Weight per 10	Order Code
18m (60')	740g	KEN-512 -2180K

SENATOR Builder's Trowel

Ground polished, hardened and tempered high carbon steel alloy blades, tapered to remain rigid right to the tip with high angle handles for improved knuckle clearance and control. Chromed ferrules hold the forged tang firmly.

Broad Heel Brick Trowel

11" heel width. London pattern, a smooth rounded end wooden handle with integral tang.



Overall Length	Type	Order Code
280mm (11")	London	SEN-512 -0060K

Pointing Trowel

Ground polished, hardened and tempered high carbon steel alloy blade, high angle handle. Chromed ferrule holds the forged tang firmly. London pattern, a smooth rounded end wooden handle with integral tang.



Overall Length	Width (mm)	Order Code
150mm (6")	75	SEN-512 -0020K

Gauging Trowel

London pattern, a smooth rounded end wooden handle with integral tang.



Overall Length	Width (mm)	Order Code
180mm (7")	90	SEN-512 -0040K

KENNEDY PROFESSIONAL Professional Brick Trowel

Manufactured from high carbon tempered and hardened steel with a ground and polished finish, tapered to remain rigid to the tip. Polished and varnished high angle handle, with chromed ferrule, holds the tang in place preventing the blade from twisting.



Overall Length	Width (mm)	Order Code
280mm (11")	140	KEN-512 -0060K

Professional Pointing Trowel

Made from high carbon tempered and hardened steel with a ground and polished finish. Tapered to remain rigid to the tip. Polished and varnished high angle handles for greater balance, control and knuckle clearance, with chromed ferrule. Holds the forged steel tang in place preventing the blade from twisting.



Overall Length	Width (mm)	Order Code
150mm (6")	75	KEN-512 -0020K

Gauging Trowel

London pattern, a smooth rounded end wooden handle with integral tang.



Overall Length	Width (mm)	Order Code
180mm (7")	90	KEN-512 -0040K

KENNEDY Standard Industrial
Terminal

Durable low cost copper or brass connectors. Manufactured as single piece connectors. Electro tinned to protect from corrosion. Insulated with flared entry, colour coded vinyl sleeves. All disconnect terminals supplied with anti-vibration copper sleeve.

Push-on Female and Male Tab Connector Terminals
Pack quantity: 100.



Type	Colour	Tab Size (mm)	Order Code KEN-515
Push-on	Red	6.3 x 0.8	-3000K
Push-on	Blue	6.3 x 0.8	-3010K
Push-on	Yellow	6.3 x 0.8	-3020K
Tab	Red	6.3 x 0.8	-3700K
Tab	Blue	6.3 x 0.8	-3710K
Tab	Yellow	6.3 x 0.8	-3720K

Push-on Fully Insulated Female Connector Terminals
Pack quantity: 100.



Type (Female)	Colour	Tab Size (mm)	Order Code KEN-515
Push-on	Red	6.3	-1520K
Push-on	Blue	6.3	-1500K
Push-on	Yellow	6.3	-1540K

Push-on Piggy Back Terminals
Pack quantity: 100.



Type (Female)	Colour	Tab Size (mm)	Order Code KEN-515
Push-on	Red	6.3	-3730K
Push-on	Blue	6.3	-3740K

Heat Shrink Tubing Kits

Suitable for connecting, end handling, electric wire insulating and harnessing, corrosion proofing metal rods and tubes, antenna protection. Made from halogen-free environmentally friendly polyolefin which is flame retardant and RoHS compliant. It's operating temperature is from 55°C to 125°C and shrinking starts at 70°C and becomes totally shrunk at 110°C. It's shrink ratio is 2:1 and has a maximum electrical rating of 600V. Assorted colours. For use with heat guns and gas torches.



Number of Pieces	Tube Dia. (mm)	Order Code KEN-515
32	4.8 (16), 6.4 (12), 9.5 (4)	-6800K
171	2 - 18 (Assorted)	-6900K
181	2 - 9 (Assorted)	-6910K

Blade Connector Terminals
Pack quantity: 100.



Type	Colour	Size (mm) Dia. x L	Order Code KEN-515
Blade	Red	2.3 x 10.4	-2000K
Blade	Red	1.9 x 18.4	-2010K
Blade	Blue	2.8 x 9.0	-2050K
Blade	Blue	2.3 x 18.4	-2060K
Blade	Yellow	2.8 x 10.0	-2100K

Fork and Ring Connector Terminals
Pack quantity: 100.



Type	Colour	Tab Size (mm)	Order Code KEN-515
Fork	Red	3.2	-2200K
		3.5	-2210K
		4.0	-2220K
		5.0	-2230K
		6.0	-2240K
Fork	Blue	3.2	-2260K
		3.5	-2270K
		4.0	-2280K
		5.0	-2290K
		6.0	-2300K
Fork	Yellow	3.0	-2320K
		4.0	-2330K
		5.0	-2340K
		6.0	-2350K
		3.0	-2400K
Ring	Red	3.7	-2410K
		4.0	-2420K
		5.0	-2430K
		6.0	-2440K
		8.0	-2450K
Ring	Blue	10.0	-2460K
		3.0	-2500K
		3.7	-2510K
		4.0	-2520K
		5.0	-2530K
Ring	Yellow	6.0	-2540K
		8.0	-2550K
		10.0	-2560K
		12.0	-2570K
		3.0	-2600K
Ring	Blue	4.0	-2620K
		5.0	-2630K
		6.0	-2640K
		8.0	-2650K
		10.0	-2660K
Ring	Yellow	12.0	-2670K

Butt Connector Terminals
Pack quantity: 100.



Type	Colour	Pack Quantity	Order Code KEN-515
Butt	Red	100	-2900K
Butt	Blue	100	-2910K
Butt	Yellow	100	-2920K

Female Socket and Male Bullet Connector Terminals
Pack quantity: 100.



Type	Colour	Bullet Dia. (mm)	Order Code KEN-515
Socket	Red	4.0	-3100K
Socket	Blue	4.0	-3110K
Socket	Yellow	5.0	-3120K
Bullet	Red	5.0	-3130K
Bullet	Blue	4.0	-3500K
Bullet	Blue	4.0	-3510K
Bullet	Blue	5.0	-3520K
Bullet	Yellow	5.0	-3530K



KENNEDY Multi-Purpose Crimping Plier Kit

Made from heavy gauge carbon steel heat treated to HRa 65/70. Chemically blackened with cushion grip handles for operator comfort.

Kit comes complete with 100 assorted insulated and non-insulated terminals in a neat plastic see through box.

Strip range: 0.75 - 6.
Crimp/cut capacity: 1.5 - 16mm.

**100
PIECES**



Description	Order Code
Plier only	KEN-515
100 Piece Kit	-5050K
	-5090K

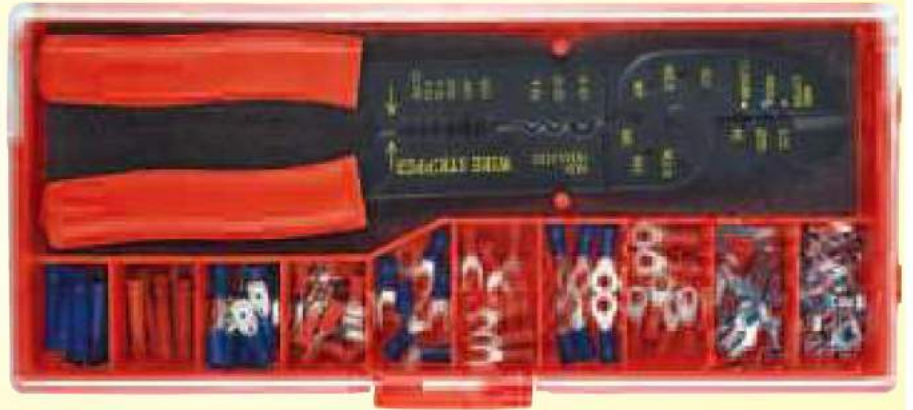

Terminals - Spades/Bullets/ Butt Connectors

Contents:

Butt connectors: red, blue and yellow.

Spade connectors (push-on female): 6.3mm - red, blue and yellow.

Female bullet connectors: 4mm - red, and blue.

Male bullet connectors: 4mm - red and blue.

Average quantity: 240 pieces.



Weight each	Order Code
0.40kg	KEN-515
	-5610K

Terminals - Rings/Forks

Red ring 4BA, 2BA and 1/4. Blue ring 2BA, 1/4 and 5/16.

Yellow ring 1/4, 5/16 and 3/8. Spade blue, red and yellow.

Average quantity: 300 pieces.



Weight each	Order Code
0.60kg	KEN-515
	-5620K

5-Way Stripping & Crimping Kit

240mm heavy gauge hardened carbon steel wire crimper with anvil action cutters and PVC grip.

Insulation terminals: 1.5mm² (red), 2.5mm² (blue) and 6.0mm² (yellow).

Wire cutters: M2.6, M3.0, M3.5, M4.0 and M5.0mm.

Non insulated terminals: 1.5mm², 2.5mm² 4.0 - 6.0mm².

Wire strippers: 0.75, 1.0, 1.5, 2.5, 4.0 and 6.0mm².

Kit Contents: 40mm 5-Way Crimping Tool.

Blade connectors: red - 2.3 x 10.4mm, blue - 2.8 x 9.0mm.

Push-on spade connectors - male: red - 6.3 x 0.8mm, blue - 6.3 x 0.8mm.

Push-on spade connectors - female: red - 6.3 x 0.8mm, blue - 6.3 x 0.8mm.

Butt connectors: red - 0.5 x 1.5mm², blue - 1.5 x 2.5mm².

Bullet connectors - male: red - 4.0mm², blue - 4.0mm².

Bullet connectors - female: red - 4.0mm, blue - 4.0mm.

Fork connectors: red - 4.0mm, blue - 4.0mm, yellow - 4.0mm.

Ring connectors: red - 4.0mm, blue - 4.0mm, yellow - 6.0mm.

**361
PIECES**



Order Code
KEN-515
-5530K

Heavy Duty Ratchet Crimping Tool Kit

Heavy duty 220mm ratchet crimper with a selection of pre-insulated red, blue and yellow electrical connector terminals, cable ties and insulation tape. Ratchet crimper has laminated steel jaws with strengthened PVC handle grips.

Suitable for crimping insulated terminals as follows: red channel: 0.5 - 1.00mm², blue channel: 1.5 - 2.5mm², yellow channel: 4.0 - 6.0mm².

Supplied in a fitted case with slide locking clips and handle.

Kit contents: Heavy duty ratchet crimper, black insulation tape (19mm x 9m), black cable ties (2.5 x 100mm).

Ring connectors: red - 3.7, 4, 5mm, blue - 3.7, 4, 5, 6mm, yellow - 4, 5mm.

Butt connectors: red - 1.5 x 1.5mm², blue - 1.5 x 2.5mm².

Push-on spade connectors - male: red, blue, yellow - 6.3 x 0.8mm.

Push-on spade connectors - female: red, blue, yellow - 6.3 x 0.8mm.

Push-on spade covered connectors - female: red, blue - 6.3 x 0.8mm.

Push-on piggy back connectors - female: red, blue - 6.3 x 0.8mm.

Bullet connectors - male: red, blue - 4mm.

Bullet connectors - female: red, blue - 4mm.

**552
PIECES**



Order Code
KEN-515
-5540K

PRODUCTS ARE ONLY AVAILABLE VIA YOUR DISTRIBUTOR

KENNEDY Uninsulated Terminal Crimp Tool
QUALITY IMPROVEMENT TOGETHER

Uninsulated terminal crimp tool with full cycle ratcheting crimp frame and adjustable crimp pressure. Carbon steel jaws with a chemically blacked finish and PVC handles.

Tab width: 6.3mm.

Capacity: 0.5 - 1.0, 1.0 - 2.5 and 4.0 - 6.0mm.



Product Number	Order Code	Description	Order Code
TCU006	KEN-515 -5400K	Replacement Jaws	KEN-515 -6400K

Uninsulated Terminal Crimp Tool

Uninsulated terminal crimp tool with full cycle ratcheting crimp frame and adjustable crimp pressure. Carbon steel jaws with a chemically blacked finish and PVC handles.

Capacity: DIN 1 - 2, 6, 10 and 16mm.,
AWG 14, 10, 8 and 6.

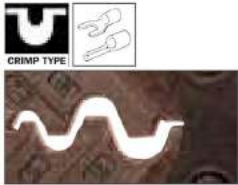

Product Number	Order Code	Description	Order Code
TCU016	KEN-515 -5420K	Replacement Jaws	KEN-515 -6420K

Ferrule Crimp Tool

Ferrule crimp tool with full cycle ratcheting crimp frame and adjustable crimp pressure. Carbon steel jaws with a chemically blacked finish and PVC handles.

TCF 004

Capacity: 0.5, 0.75, 1.0, 1.5, 2.5 and 4mm.,
AWG 20, 18, 17, 16, 13 and 11.

TCF 016

Capacity: 6, 10 and 16mm.,
AWG 10, 8 and 6.



Product Number	Order Code	Description	Order Code
TCF004	KEN-515 -5200K	Replacement Jaws (TCF004)	KEN-515 -6200K
TCF016	KEN-515 -5210K	Replacement Jaws (TCF016)	KEN-515 -6300K

Insulated Terminal Crimp Tool

Insulated terminal crimp tool, with full cycle ratcheting crimp frame and colour coded jaws, with adjustable and preset crimp pressure for accurate crimping. Carbon steel, hardened and tempered jaws with a chemically blacked finish and PVC handles.

Capacity:

Red: 0.5 - 1.5mm., AWG 20 - 16.

Blue: 2.5mm., AWG 14.

Yellow: 4.0 - 6.0mm., AWG 12 - 10.

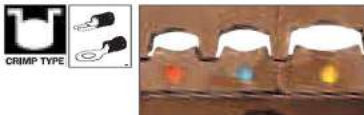

Product Number	Order Code	Description	Order Code
TCI006	KEN-515 -5220K	Replacement Jaws	KEN-515 -6220K

HAND TOOLS

Coaxial Crimp Tool

Coaxial crimp tool with full cycle ratcheting crimp frame and adjustable crimp pressure. Carbon steel jaws with a chemically blacked finish and PVC handles.

Suitable for RG cable: 6, 58, 59 and 62.
 Hexagonal crimp of 1.72, 2.5, 5.4, 6.48 and 8.22mm.



Product Number	Order Code	Description	Order Code
TCC008	KEN-515 -5340K	Replacement Jaws	KEN-515 -6340K

Modular Plug Crimp Tool

Modular plug crimping tool complete with wire cutting and stripping facilities. Manufactured from hardened and tempered carbon steel with chemically blacked finished and tempered jaws with PVC handles.

Capacity: 8P8C/RJ-45, 6P/RJ-12, RJ-11 and 6P2C.



Product Number	Order Code
TMCT008	KEN-515 -5460K

Heavy Duty Crimp Tool

Heavy duty crimp tool for uninsulated terminals. Tool steel jaws and manufactured from ductile iron.

Capacity: cable lugs: 10mm, - 95mm, . Aluminium AWG to 4/0. Copper 8WG to 250 MCM.



Product Number	Order Code	Description	Order Code
TCU095	KEN-515 -5440K	Replacement Jaws	KEN-515 -6440K

PRODUCTS ARE ONLY AVAILABLE VIA YOUR DISTRIBUTOR

© 2018

KENNEDY Crimping
Tool Sets

Adaptable crimping tool with 4 easy-change jaws to meet your crimping needs. The design features a ratchet handle to enable the application of consistent pressure, as well as a quick release lever, tension adjustment wheel, locking screw and soft grip handles. Heat treated steel with a Zinc Phosphate surface finish.

KRC07 7 Jaw Ratchet Crimping Tool Set

Jaws supplied:

Insulated Terminal:0.5- 6.0mm²

Non-insulated Terminal:1.5mm² - 10mm²

Open Barrel Terminal:0.5 - 6.0mm²

Cord End Terminal (Small AWG):0.5mm² - 4.0mm²

RG Type Coaxial Cable Connector: RG 58, 59, 62 and 6, 6.48mm - 8.23mm

Cord End Terminal (Large AWG):0.5mm² - 16.0mm²

Open Barrel Terminal 7 D-SUB, V3.5:2.5mm² - 8.0-10.0mm²



**TOOL-FREE
QUICK RELEASE
JAW CHANGING**

Product Number	Size	Order Code
KRC07	7	KEN-515 -5740K

HAND TOOLS



KRC04 4 Jaw Ratchet Crimping Tool Set

Jaws supplied:

Insulated Terminal: 0.5-1.0mm² - 4.0-6.0mm²

Non-insulated Terminal: 1.5mm² - 10mm²

8 Position 8 Connector: 8P8C/RJ45 Plugs

RG Type Coaxial Connector: RG 58, 59, 62 and 6, 6.48mm - 8.23mm

Product Number	Size	Order Code
KRC04	4	KEN-515 -5710K

Crimp Type	Order Code KEN-515			
Insulated Terminals 0.5mm ² - 6.0mm ²	-5100K			
Non-Insulated Terminals 1.5mm ² - 10mm ²	-5110K			
Open Barrel Terminals 0.5mm ² - 0.6mm ²	-5120K			
Cord End Terminals Small AWG 0.5mm ² - 4.0mm ²	-5130K			
RG Type Coaxial Cable Connectors RG58-6/6.48-8.23mm	-5140K			
Insulated Cord End Terminals Large 0.5mm ² - 16.0mm ²	-5150K			
Open Barrel Terminal 7 D-Sub V3.5 -0.5mm ² - 6.0mm ²	-5160K			
8 Position 8 Connector 8P8C/RJ45	-5170K			

Replacement Jaws To suit Kennedy ratcheting frame crimping tools.
KEN-515-5710K & KEN-515-5740K





Standard Nylon Cable Ties

Width Max. Tensile. Suitable for securing or retaining cable / pipe UL approved polyamide 6.6, 94V-2 bundles and objects of various shapes and sizes. The design of the head guarantees a high tensile strength while allowing a very low insertion force.

- Manufactured from high quality nylon: UL approved polyamide 6.6, 94V-2
- Heat resistant up to 85°C
- Flame-retardant
- Supplied in a pack of 100

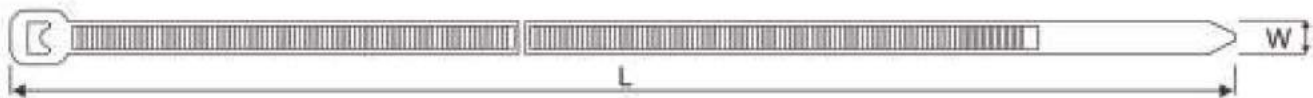
All Dimensions are approximate.



Product Number	Length L (mm)	Width W (mm)	Max. Bundle Dia. (mm)	Tensile Strength (kg)	Order Code EDI-515	
					Black	White
CT1	2.5	100	22	8.1	-0000K	-1000K
CT23	2.5	160	40	8.1	-0010K	-1010K
CT4	2.5	200	102	22.2	-0020K	-1020K
CT2	3.6	140	53	18.2	-0100K	-1100K
CT20	3.6	200	10	8.1	-0110K	-1110K
CT7	3.6	300	33	18.2	-0120K	-1120K
CT29	3.6	370	76	18.2	-0130K	-1130K
CT25	4.8	120	24	22.2	-0200K	-1200K
CT5	4.8	200	110	22.2	-0210K	-1210K
CT8	4.8	300	76	22.2	-0220K	-1220K
CT10	4.8	370	53	18.2	-0230K	-1230K
CT12	4.8	430	38	18.2	-0240K	-1240K
CT6	7.6	200	50	54.4	-0300K	-1300K
CT9	7.6	300	76	54.4	-0310K	-1310K
CT11	7.6	368	10	54.4	-0320K	-1320K
CT35	7.6	450	13	54.4	-0330K	-1330K
CT16	9	526	140	79.4	-0400K	-1400K
CT21	9	780	228	79.4	-0410K	-1410K
CT48	12	580	204	114	-0500K	-1500K

HAND TOOLS
KENNEDY
QUALITY INDUSTRIAL TOOLING
Cable Tie Gun

Steel jaws grip the cable with trigger action for rapid tightening, tensioning and trimming, ideal for production environments.



Capacity (mm)	Order Code
2.4 - 4.8	KEN-516 -8400K

Magnetic Cable Guider

An innovative tool for inserting cables through brick walls, cavity walls, studwork etc. Tested by major utilities - saves hours of engineer's time. Includes three adaptors for 3.7 to 5.9mm cable diameters. Drill bit not included.

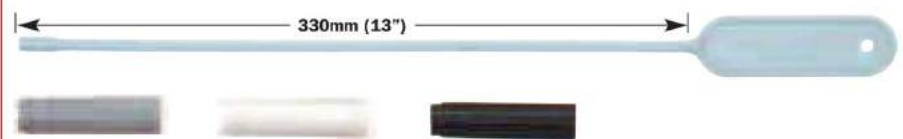

Push through cable guider

Attach to guider and pull back through



Type	Order Code
Cable Guider	KEN-516 -9600K
Caps (Pk 6)	-9620K

NOT FOR USE WITH LIVE CABLES!
PRODUCTS ARE ONLY AVAILABLE VIA YOUR DISTRIBUTOR

KENNEDY No.500 Cable Stripper/
Screwdriver/Volt Tester

The newly developed Multi-Stripper PLUS, screwdriver, voltage tester, stripper for conductors, round and coaxial cables and cutter in only one tool.

Screwdriver: two double ended bits:

No.1PZ and 8855; x 3.5 slotted No.2PZ and 8855: x 4.0 slotted bit storage inside ergonomic dual material handle.

Voltage tester: 110 - 250V.

Round cable stripper: capacity 8 - 13mm dia (eg NYM 3x 1.5mm - 5x 2.5mm).

Built-in side cutter: for PVC-isolated round cables max. 9mm dia.

Coax stripper: two or three-level stripping of all common coaxial cables of 4.8 - 7.5mm dia.

Wire stripper: for all common stranded and solid conductors 0.5mm (20AWG) to 6.0mm (10AWG).



Capacity (mm ²)	Order Code
8.0 - 13.0	KEN-516
	-8340K

Cable Strippers

Durable plastic bodies with hardened and ground sharpened steel blades with precise depth of cut adjustment. Spring loaded safety cover, covers the blade when not in use. For standard and solid conductors. Hardened steel blades.

CS16

For stripping of all common round cables of 4 - 16mm. Wire stripper adjusts automatically to diameter of wire to allow quick and accurate stripping. Stripping blades are made from hardened steel.

Overall length: 125mm.



CS27

For stripping of all common round cables of 4 - 28mm. Wire stripper adjusts automatically to diameter of wire to allow quick and accurate stripping. Stripping blades are made from hardened steel.

Overall length: 130mm.



CS28

Complete with hook knife for splitting flat and ribbon cables along its length.

Overall length: 170mm.



Product Number	Capacity (mm ²)	Weight each	Order Code
CS16	4.0 - 16.0		-7900K
CS27	8.0 - 27.0		-7910K
CS28	4.0 - 28.0		-7920K
Spare blade suit CS16, CS27 & CS28		125g	-7950K

KENNEDY Cable Stripper & Ripper

MK02

For stripping of outer insulation from cables. Spring loaded gripping arm, blade has adjustable cutting depth of up to 3mm. Blade can be turned through 90° by pushing the side button, to cut along the length of cable. Also features a spring loaded ripping blade for insulation removal.

Overall length: 138mm.



Capacity (mm ²)	Order Code
4.5 - 28.0	KEN-516 -8040K
5 Spare Blades	-8030K

Wire Stripper, Cutter & Crimper
Duo Crimp

Combined stripping and crimping tool. Stripping tool adjusts automatically to the diameter of the wire.

Two crimping ranges are available 0.5 - 1.5mm² and 2.5 - 6.0mm². Complete with side wire cutter.

Overall length: 155mm.



Capacity (mm ²)	Weight each	Order Code
0.5 - 6.0	150g	KEN-516 -8520K

Multi-Stripper PLUS

Cable stripper for round and continental type cables of 8 - 13mm dia (e.g. NYM 3x 1.5mm² up to 5x 2.5mm²).

Flush stripping even in hard-to-reach areas, e.g. ceiling and wall areas, junction and distribution boxes, switch cabinets, etc. The ergonomic tool design provides a sure grip and safe handling. Needs no adjustment of the cutting depth.



Capacity (mm ²)	Order Code
0.5 - 6.0	KEN-516 -8300K

Mains Testers

With heavy duty one-piece moulded insulation sheaths covering both blade and transparent plastic handle for extra protection and safety.

Will detect 'live' electricity supply. Suitable for AC to 125 - 250V. 3mm wide tip. Conforms to **DIN VDE 0680 part 6:1977-04**.



Blade Length	Cap Type	Weight per 12	Order Code
150mm	Plastic	210g	KEN-515 -0500K
190mm	Plastic	400g	-0550K

Wire Stripper & Cutter

Unique self-adjusting cutting action for rapid repeatable wire stripping. Hardened and tempered ground steel blades housed in durable plastic bodies contoured to fit comfortably into the hand for extended periods of use encountered in electrical assembly industries.

Mini-Duo Wire Stripper & Cutter

Fully insulated wire stripper for all common stranded and solid conductors of 0.5 - 6.0mm². Adjusts automatically to diameter of wire. Blades are made from hardened steel.

Overall length: 155mm.



Capacity (mm ²)	Order Code
0.5 - 6.0	KEN-516 -7980K

Super Wire Stripper & Cutter

Fully insulated for all stranded and solid conductors from 0.2 to 6mm². Automatically adjusts to the diameter of wire. Reinforced polyimide construction.

Overall length: 195mm.



Capacity (mm ²)	Order Code
0.2 - 6.0	KEN-516 -7970K

Electrician's Shears

For use on soft cable up to 22mm² diameter, can also be used for stripping, cutting insulation materials, electrical tape and cable ties. Stainless steel blades with hardened edge with vanadium and molybdenum for long lasting edge. HRC58-60 with one cutting edge serrated to reduce slipping and notched blade for tough and large diameter cuts. Tough, lightweight nylon handles. Supplied with handy clip-on belt pouch.

Cutting length: 45mm (1¾").

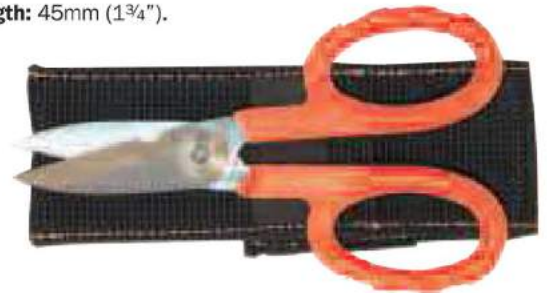

Length (mm)	Weight each	Order Code
140	150g	KEN-516 -6400K

KENNEDY Powerstrip
 Wire Stripper

Self adjusting. Wire is gripped and stripped in a single action. Also features a wire cutter to allow for trimming. Adjustable slide and lock wire stop for fast accurate setting of strip length.

Overall length: 175mm.



Capacity
(mm²)
1.25 - 6.0

Order Code
KEN-516
-8065K

SENATOR Automatic
 Wire Stripper

For stripping single core wire up to 6mm diameter. Also with bypass action cutting blades for wire up to 6mm diameter.



Capacity
(mm²)
6.0

Order Code
SEN-516
-8240K

Cable Stripping Knife

Steel blade and cushioned handle, used for stripping cable and wire.

Overall length: 150mm.



Order Code
KEN-516
-7500K

KENNEDY Fibre Optic
 Cutter

FOC145

Designed for cutting fibre optics, KEVLAR materials, plastic canvas, upholstery, headlines, cloth, fabric, string and many more. Lightweight and easy to use for both right and left handed users. Easy reach thumb lock. Long lasting precision ground hardened high carbon alloy steel with molybdenum and vanadium blades. Serrated blade reduces slippage.

Overall length: 145mm (5").
Cutting length: 32mm (1").



Weight
each
82g

Order Code
KEN-533
-3570K

Fibre Optic Shears - with Serrated Blade
FOC160

Designed for cutting fibre optics, KEVLAR materials, plastic canvas, upholstery, headlines, cloth, fabric, string and many more. Lightweight and easy to use for both right and left handed users. Long lasting precision ground hardened high carbon alloy steel with Molybdenum and Vanadium blades. Serrated blade reduces slippage. Adjustable pivot point adjusts the tension between the blades. Extended tang for durability.

Overall length: 160mm
Cutting length: 42mm.



Weight
each
82g

Order Code
KEN-533
-3580K

Co-axial Cable Cutter

Two preset pairs of blades, one for outer sheathing, one for dielectric. For cable diameter range of 4.8 - 7.5mm². Also strips flexible cables of 3 x 0.75mm², 10mm² and 16mm².

Overall length: 110mm.



Capacity (mm²)
4.8 - 7.5

Order Code
KEN-516
-7960K

Butane soldering irons can be used anywhere, any time, without having to plug into the wall. They don't have power cables making them ideally suitable for fine work. The run time for the irons varies from 30 to 90 minutes, depending on model and heat setting, but refilling them with butane gas only takes about 20 seconds. They offer more flexibility than traditional soldering irons as you can change the size of the soldering tips, put hot blow air tips for heat-shrink work, put hot knife tips on for cutting plastic, and flame tips for brazing. The temperature can be controlled very easily for each application (580°C to 1,300°C) with the temperature adjustment dial. Butane soldering irons don't use an open flame, unless using the flame tip. There are small catalytic combustion screens built into the other tips, which heat up and glow so that soldering iron won't flame out.



KENNEDY Butane Soldering Tools

Flint type ignition which is built into the cap. Uses standard butane lighter fuel and is simple to refill. Fully adjustable tip temperature control with a safety fuel cut-off when cap is replaced. Textured anti-slip barrel. Supplied with pointed soldering tip. Can be used with double flat, hot air, flame and hot knife, can also be used as a blow torch. Supplied without fuel.



Power rating:	50W
Soldering temperature	375°C
Run time	60 minutes
Overall length with cap:	195mm
Overall length with soldering tip:	180mm.

Product Number	Weight each	Order Code
BS050	100g	-9000K



Butane Soldering Iron Tips

Interchangeable tips for use with Kennedy butane soldering tools.



2.4 to 4.8mm Double Flat Tip



Fine Tip



Hot Knife Tip

To Suit BS050 Soldering Iron

Type	Size (mm)	Order Code
Double Flat Tip	2.4	-9050K
Fine Tip	4.8	-9040K
Hot Knife Tip		-9070K

Butane Soldering Tool Kit

Supplied in a robust plastic case with inlay.

Contents:

BS050 Butane soldering iron, tip cleaning sponge, stand, four interchangeable tiptets: fine, 2.4mm chisel, 4.8mm double flat and knife.



Order Code
KEN-516
-9020K

SENATOR QUALITY TOOLING



Butane Micro Soldering Tool



Cordless and refillable. Uses standard butane lighter fuel. 120W rating. Working temperature range up to 1,300°C. Lightweight, windproof flame, ideal for outdoors. Easily removed nozzle for cleaning or replacement. Can be used for shrinking heat seal plastic tubing. Light duty soldering. Craft projects. Thawing frozen locks. Includes one refillable fuel cartridge.

Weight each
105g

Order Code
SEN-516
-2000K

HAND TOOLS

PRODUCTS ARE ONLY AVAILABLE VIA YOUR DISTRIBUTOR

© 2018