

**GROUP
593**

TOOL POUCHES



**Nail Pouches -
Leather**

Leather, two pockets and one loop. Double stitched seams with riveted corners for extra strength. Webbed nylon belt.



Size (mm)	Weight each	Order Code
370 x 220	290g	KEN-593 -3240K

Leather, two pockets, one loop, deep pocket. Double stitched seams with riveted corners for extra strength.



Size (mm)	Weight each	Order Code
360 x 250	370g	KEN-593 -3340K

Leather Belts - Heavy Duty

Heavy duty natural split leather with heavy buckle and retaining loop.



Size (mm)	Weight each	Order Code
1170 x 50	260g	KEN-593 -3000K
1170 x 40	210g	-3020K

Heavy duty oil tan belt with brass buckle and rivets for use with Kennedy tool pouches.



Size (mm)	Weight each	Order Code
1170 x 50	309g	KEN-593 -3080K

Polyester & Nylon Belt

Adjustable webbing. Riveted for added strength and support.



Colour	Size (mm)	Weight each	Order Code
Black	1200 x 50	120g	KEN-593 -3060K

Combination Pouches

Leather, made with one pocket, two loops and nail pouch. Belt not included.



Tools Not Included

Size (mm)	Weight each	Order Code
280 x 270	310g	KEN-593 -3600K

Manufactured from leather with a fully riveted double stitched construction. Chrome leather, five pockets and one loop. Belt not included.



Tools Not Included

Size (mm)	Weight each	Order Code
210 x 250	340g	KEN-593 -3450K

Leather, made with five pockets and one loop. Belt not included.



Tools Not Included

Size (mm)	Weight each	Order Code
250 x 280	360g	KEN-593 -3460K

Leather, made with five pockets, two loops, webbing belt and tape holder.



Tools Not Included

Size (mm)	Weight each	Order Code
220 x 210	300g	KEN-593 -3470K

HAND TOOLS



TOOL POUCHES

KENNEDY PROFESSIONAL Nail Bag - Nylon

Heavy duty polyester allows exceptional resistance to punctures or tears. Heavily stitched webbing belt complete with heavy duty double capped riveted clasp for added strength and support.



Size (mm)	Weight each	Order Code
525 x 290	0.31kg	-3540K

Combination Tool Pouch Double Nail Bag & Combination Tool Pouch

Heavy duty polyester allows exceptional resistance to punctures or tears. Heavily stitched webbing on belt loop and edges, and double capped riveted for added strength and support.



Size (mm)	Order Code
270 x 200 x 50 (x2)	KEN-593
130 x 120 x 80 (x2)	
140 x 100 x 50 (x1)	-3400K

KENNEDY Double Tool Pouch

10 Pocket 2 Loop Double Tool Pouch - Oil Tan
Manufactured from butt split leather. Fully riveted construction. 10 pockets with T-bar chain and spring clips. Belt supplied separately.



Size (mm)	Weight each	Order Code
280 x 300	1.2kg	-3260K

KENNEDY PROFESSIONAL Combination Tool Pouches

Leather, made with ten pockets, two loops, webbing belt and tape holder.



Tools Not Included

Size (mm)	Weight each	Order Code
550 x 220	330g	-3500K

Leather, made with eight deep pockets, two nail pouches, two loops, webbing belt and tape holder.



Tools Not Included

Size (mm)	Weight each	Order Code
550 x 220	670g	-3510K

Tool Pouches

Manufactured from leather. Fully riveted double stitched construction. Chrome leather, two pockets and five loops. Belt not included.



Tools Not Included

Size (mm)	Weight each	Order Code
290 x 200	300g	-3640K

Electrician's Tool Pouch

Manufactured from natural split leather, four pockets, seven tool loops, T-bar and chain, spring clip, tape pocket. Fully riveted construction. Belt not included.



Size (mm)	Weight each	Order Code
200 x 260	410g	-3770K

Tool Pouch - Large

4 Pocket 2 Loop Tool Pouch - Oil Tan
Large tool pouch with four pockets and two tool loops. Fully brass riveted construction. Manufactured from oil tanned leather.



Size (mm)	Weight each	Order Code
300 x 230	965g	-3270K

Nail & Tool Pouch - Large

3 Pocket 2 Loop Nail & Tool Pouch - Oil Tan
Large nail and tool pouch with three pockets and two tool loops. Fully brass riveted construction. Manufactured from oil tanned leather.



Size (mm)	Weight each	Order Code
300 x 230	695g	-3280K

HAND TOOLS

PRODUCTS ARE ONLY AVAILABLE VIA YOUR DISTRIBUTOR

**GROUP
593**

TOOL POUCHES



Spanner/Tool Holster

Manufactured from natural split leather. Two spanner, tan leather. Reinforced joints. Belt not included.



Tools Not Included



Size (mm)	Weight each	Order Code
170 x 110	90g	-3710K

Drill Holster

Manufactured from natural split leather, fitted with two additional tool loops and an adjustable drill safety strap, four slits for belt attachment, riveted construction. Tan leather with chuck key holder, adjustable retaining strap and one tool loop. Belt not included.



Tools Not Included



Size (mm)	Weight each	Order Code
300 x 200	250g	-3160K

Plier/Wrench Holster

Leather-made with a 100 x 45 x 30mm pocket fully stitched and riveted at corners - double riveted at base. Two slots for belt attachment. Belt not included.



Tools Not Included



Size (mm)	Weight each	Order Code
75 x 230	90g	-3740K

HAND TOOLS

Plier/Wrench Holster

Manufactured from natural split leather. 90mm tapered pouch with a 40 x 25mm opening. Fully riveted construction. Two slots for belt attachment. Belt not included.



Tools Not Included



Size (mm)	Weight each	Order Code
85 x 90	100g	-3800K

Hammer Holster

With pivoting metal hammer loop, riveted onto natural split leather, with two slits for belt attachment. Belt not included.



Tools Not Included



Size (mm)	Weight each	Order Code
100 x 150	130g	-3100K

Carpenter's Full Bib Apron

100% cotton drill, with cotton neck loop and ties. Two single stitched pockets.



Size (mm)	Weight each	Order Code
850 x 620	200g	-4010K

Trimming Knife Holster

Manufactured from natural split leather. 100mm tapered pocket with a 40 x 20mm opening. Fully riveted construction. Two slits for belt attachment. Belt not included.



Tools Not Included



Size (mm)	Weight each	Order Code
60 x 190	80g	-3750K

Hammer & Tool Holster

Manufactured from natural split leather with four medium and one large leather tool loops. Riveted metal tool clip with metal T-bar and chain. Six slits for attaching to belt. Fully riveted construction. Belt not included.



Tools Not Included



Size (mm)	Weight each	Order Code
240 x 75	150g	-3140K

KENNEDY PROFESSIONAL Mobile Phone Case



Polyester

Heavy duty nylon with stitched webbing trim. Front flap opening secured with velcro with optional webbing belt loop or stainless steel double capped riveted clip. 600 denier durable fabric hook and loop secured front flap. Complete with belt loop and clip.



Size (mm)	Weight each	Order Code
125 x 65 x 25	0.45g	-5010K

KENNEDY PVC-Coated Fibre Board Tool Case

Waterproof, puncture resistant and rot proof PVC outer encasing rigid fibre board. Grained finish with 36 elasticated tool loops. Full zip around fastener. Black finish.



Tools Not Included

Size (mm)	Weight each	Order Code
315 x 30	350g	-0310K

PVC Multi-Tool Rolls

Waterproof, puncture resistant and rot proof PVC outer with heavy-duty nylon weave providing a high strength, abrasion resistant inner lining. With 8 flat tool pockets, webbed ties. Tools secured with flap cover.



Tools Not Included

Size (mm)	Weight each	Order Code
390 x 330	190g	-0370K

Tear Resistant Tool Roll

Manufactured from heavy-duty tear resistant material with reinforced stitched edging. Two metal rings for hanging on to a wall when opened. 20 pockets, 18 elasticated tool loops are stitched on the inside. A velcro fastening secures the roll when shut.

Fitted with a riveted carry handle on the outside.



Size (mm)	Weight each	Order Code
600 x 540	502g	-0500K

PVC-Coated Rayon Tool Rolls

Waterproof, puncture-resistant and rot proof PVC outer with soft non-scratch rayon inner to protect tools.

Multi - With 14 pockets. Tools secured by flap cover with two webbed ties.



Tools Not Included

Size (mm)	Weight each	Order Code
650 x 270	270g	-0870K

Multi - With 12 pockets and two pouches. Tools secured by flap cover with two webbed ties.



Tools Not Included

Size (mm)	Weight each	Order Code
750 x 310	420g	-0880K

TOOL ROLLS

PVC Double-Coated Nylon Multi-Tool Roll

Puncture resistant and rot proof PVC outer encasing heavy-duty nylon weave. 100% waterproof, easy to clean. With 12 flat, and two pleated pockets, one large end pouch divided into two with a press stud containing flap. Tools secured with flap cover. Leather tie with metal buckle.



Tools Not Included



Size (mm)	Weight each	Order Code
700 x 315	340g	-0520K

Chisel Roll

Waterproof chisel roll with 8 flat pockets. PVC coated cotton, with securing leather strap and metal buckle fastening. Tools secured with flap cover.



Tools Not Included

Size (mm)	Weight each	Order Code
370 x 490		-0490K

PVC-Coated Cotton Multi-Tool Rolls

Waterproof, puncture-resistant and rot proof PVC outer with medium duty, non-scratch cotton inner. With 15 pleated pockets, two webbed ties. Tools secured with flap cover.



Tools Not Included

Size (mm)	Weight each	Order Code
660 x 320	390g	-0440K

Bench Stone Holder

To suit stone size 200 x 50 x 25mm.

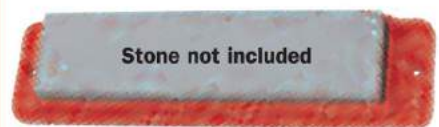

Stone not included

Weight each	Order Code
120g	-7020K

PRODUCTS ARE ONLY AVAILABLE VIA YOUR DISTRIBUTOR

SENATOR
QUALITY TOOLING**Canvas
Holdall**

Manufactured from heavy duty water resistant canvas. Handles wrap underneath the bag for added strength, fitted with a heavy-duty zip.



Length (mm)	Weight each	Order Code
460 (18")	250g	-0560K
610 (24")	335g	-0580K
760 (30")	360g	-0600K

PVC Tool Bag

The PVC makes the tool bag puncture resistant, waterproof and rot resistant. PVC holdall riveted leather handle and straps with metal buckles, fibre board base and top.



Length (mm)	Weight each	Order Code
300 (12")	230g	-0100K

KENNEDY
QUALITY INDUSTRIAL TOOLING **Barn-Type
Holdalls**

Manufactured from butt split leather with wrap around leather handles. Leather fastening straps with metal buckles. Fully rivetted construction. Reinforced on corners. Black finish.



Length (mm)	Weight each	Order Code
400 (16")	1.40kg	-0620K
535 (21")	1.80kg	-0630K

KENNEDY
QUALITY INDUSTRIAL TOOLING **Medium Weight
Holdalls**

Reinforced board base with four riveted plastic feet. Plastic zip fastening, webbing covered rope handles.



Length (mm)	Weight each	Order Code
455 (18")	390g	-0110K
610 (24")	500g	-0120K

**Heavy Duty PVC Nylon Coated
Canvas Holdalls**

Reinforced fibre board base with four riveted metal feet and zip fastening. Webbing covered rope handles and welded D-rings at either end.



Length (mm)	Weight each	Order Code
455 (8")	670g	-0180K
610 (24")	810g	-0240K
760 (30")	590g	-0300K

Jumbo Tool Bag

Heavy-duty double thickness canvas. Five internal pockets and a fibre board base with six rivetted metal feet. Webbing handles and straps with plastic buckles.



Length (mm)	Weight each	Order Code
610 (24")	1.50kg	-0060K

Canvas Holdall

Heavy-duty water resistant. Canvas covered rope handles, fully stitched, wrap underneath bag for extra support. Three webbed straps with metal buckles for closing, two of which fully wrap around the bag to give extra support.



Length (mm)	Weight each	Order Code
760 (30")	810g	-0080K

Tool Bumbag with Shoulder Strap

Made of 600 denier durable fabric with adjustable shoulder and waist straps. It has a large internal compartment with 7 internal and 1 external pockets. Heavy duty zip and padded handles.

**Tools Not
Included**

Size H x W x D (mm)	Order Code
170 x 320 x 160	-0990K



**KENNEDY
PROFESSIONAL Heavy Duty
Tool Caddy**

600 denier durable fabric. Adjustable shoulder strap. Locking telescopic handle. 26 internal pockets. 12 external pockets. Large internal compartment. Padded handles and strap. Heavy duty zip.



Size (H x W x D)	Weight each	Order Code KEN-593
370 x 480 x 260mm	2kg	-0960K

Tool Trolley Rucksack

For technicians on the go; it can be pulled behind on wheels **OR** used as a backpack **OR** hand held.

Features include:

Extractable rear straps transform tool trolley into a functional backpack. Two internal double-sided reversible pallets, one with pouches for tools and the other with a soft padded area for computer notebook. Two front pouches for documents, accessories, measuring tape, spares etc. Large wheels for a stable carry-on. Telescopic handle. Fold down wheel cover when being used as a rucksack.

**Tools Not
Included**

Size L x D x H (mm)	Weight each	Order Code KEN-593
340 x 150 x 440	4.3kg	-2530K

Heavy-Duty Tool Bags

600 denier durable fabric. Adjustable shoulder straps. Padded handles and straps. Heavy duty zips.

-0940K: 11 internal pockets. 17 external pockets. Large internal compartment.

-0980K: 13 external pockets. Large internal compartment can be divided to 5 pockets with dividers. Heavy-duty water-resistant base for extra strength. Business-card holder and key strap.



Size (H x W x D)	Weight each	Order Code KEN-593
250 x 470 x 270mm	1.3kg	-0940K
280 x 340 x 200mm	1.8kg	-0980K

Electrician's Tool Bag

Manufactured from heavy duty tear resistant material with reinforced stitched edging. Velcro fastening flap with soft touch carry handle and double webbed shoulder strap fixed with metal release clasps. Two small organiser cases stored in two outer pockets, two removable tool boards (one velcro fastened) are kept inside. Unique tool storage securing system built-in.

**Tools Not
Included**

Size L x D x H (mm)
320 x 340 x 125

Order Code KEN-593
-0560K

Multi-Purpose Tool & Laptop Bag

Ideal for service engineers. Manufactured from a 600 denier fabric that is exceptionally durable and hard wearing. With large internal compartments (one padded for a laptop), pockets and elasticated tool holders it will help to ensure you have the right tool on site when you require it.

Features include:

Padded laptop holder.
Business card holder.
Adjustable shoulder strap.
Padded handles and strap.
Heavy duty zips and rubber feet.

**Tools Not
Included**

- 3x large internal compartments.
- 15x internal pockets.
- 2x external pockets.
- 46x elasticated tool holders.

Size (H x W x D)	Weight each	Order Code KEN-593
335 x 530 x 190mm	1.5kg	-5050K

Professional Service Case

Hard wearing cordura with nylon reinforced webbing handles. Two tool boards and unique repositionable tool retaining system, ceramic sheath for hot soldering irons and three press stud pockets. Zippable.

**Tools Not
Included**

Size (mm)	Weight each	Order Code KEN-593
450 x 330 x 80	2.10kg	-2850K

PRODUCTS ARE ONLY AVAILABLE VIA YOUR DISTRIBUTOR



**Aluminium
Reinforced Case**

Impact resistant case. Two removable tool boards with elasticated tool retaining loops, one with document pocket, divided storage compartment. Double locking with two keys.



Tools Not Included

Size (mm)	Weight each	Order Code
445 x 340 x 190	2.85kg	-2550K
Spares		Order Code
		KEN-567
'D' Shape Case Handle to suit		-7604K
Locks & Keys to suit		-7605K
Upper Tool Board to suit		-7656K
Lower Tool Board to suit		-7658K

Heavy Duty Aluminium Case

High strength, impact resistant case. Reinforced edges and hinges. Rubber padded handle for comfort. Two fitted and hinged tool boards with elasticated tool retaining loops, two expandable document pockets and divided storage compartment. Double locking with two keys.



Tools Not Included

Size (mm)	Weight each	Order Code
480 x 360 x 185	2.60kg	-2650K
Spares		Order Code
		KEN-567
Locks & Keys to suit		-7605K
'D' Shape Case Handle to suit		-7610K
Upper Tool Board to suit		-7660K

Impact Resistant Service Case

Ribbed high strength plastic case with aluminium reinforced trim. Two fitted and hinged tool boards with elasticated tool retaining loops. Lockable with two keys. Padded carry handle.



Tools Not Included

Size (mm)	Weight each	Order Code
430 x 340 x 160	2.95kg	-2450K
Spares		Order Code
		KEN-567
Plastic Catch to suit		-7606K
Locks with Keys to suit		-7609K
'D' Shape Case Handle to suit		-7612K
Upper Tool Board to suit		-7664K
Lower Tool Board to suit		-7666K

Polypropylene Moulded Tool Case

The polypropylene moulded case material makes the case extremely resistant against chemical corrosion, shock, high and low temperature. The injection technique ensures constant material thickness, even in the corners. Large and thick aluminium trim, makes the case ideal for daily, heavy duty use. The case can accommodate up to three tool pallets.

Features include:

- 2x metal lid safety support stays.
- 2x metal locks with keys.
- 3x metal hinges for maximum strength.
- Ergonomic handle, rubber coated grip.
- Address label.



Size L x D x H (mm)	Weight each	Order Code
430 x 340 x 156	5.5kg	-2510K

KENNEDY Impact Resistant Plastic Case

High strength ribbed double-wall constructed case. Two fitted hinged tool boards with elasticated tool retaining loops, four repositionable dividers in the bottom compartment, expandable document pocket in the lid and two removable small parts trays. Double locking with two keys.



Tools Not Included

Size (mm)	Weight each	Order Code
465 x 350 x 200	2.85kg	KEN-593
Spares		Order Code KEN-567
Locks & Keys to suit		-7602K
'D' Shape Case Handle to suit		-7601K
Dividers to suit		-7603K
Tool Board to suit		-7654K

Service Engineer's Flight Case

Manufactured from high impact double walled HDPE polyethylene shell, corrosion-shock and temperature resistant. Full length heavy-duty piano hinge. Two expandable document pockets, two hinged and fitted tool boards with elasticated tool retaining loops. Shockproof, bottom storage area fitted with adjustable dividers and two small component boxes. The two 100mm wide rubber wheels with ball bearings and retractable telescopic aluminium handle allows the case to be moved when fully loaded with the minimum of effort. Double locking with two keys. Strong enough to be used to transport tools when travelling by aircraft.



Tools Not Included

Size (mm)	Weight each	Order Code
485 x 370 x 190	5.7kg	KEN-593
Spares		Order Code KEN-567
'D' Shape Case Handle to suit		-7601K
Locks & Keys to suit		-7602K
Upper Tool Board to suit		-7650K
Lower Tool Board to suit		-7652K

TOOL CASES

High Impact Resistant Tool Case

Manufactured from composite aluminium and rubber resin which is normally used in the automotive industry. Chromed steel hinges with lid support mechanism, two chromed steel locks with keys, a heavy duty plastic handle and four rubber feet. Inside are two secured hinged tool boards, each with 31 elasticated tool loops, an expandable document compartment, two small organisers and a customisable storage compartment with repositional dividers. Fitted with TSA locks and 4 keys.



Tools Not Included



Size (mm)	Weight each	Order Code
470 x 390 x 347	6.5kg	KEN-593
Spares		Order Code KEN-567
'D' Shape Case Handle to suit		-7601K
Locks with Keys to suit		-7608K
Upper Tool Board to suit		-7670K
Lower Tool Board to suit		-7672K

Technical Service Tool Case

Constructed from impact and temperature resistant injection moulded high thickness polypropylene. The case has a large thick aluminium trim with a strength maximising triple metal hinge, it is highly functional with a significant load carrying capability but has a classy appearance to suit the technicians image.

Features include:

Injection moulded high thickness polypropylene. Telescopic handle and heavy duty rubber wheels. Two removable tool trays. Storage area with removable dividers. Two clasps with key locks.



Size L x D x H (mm)	Weight each	Order Code
465 x 352 x 215	7.00kg	KEN-593
Spares		Order Code KEN-567
Carry Handle to suit		-5534K
Upper Tool Board to suit		-5542K
Lower Tool Board to suit		-5544K



Service Engineer's Aluminium Tool Case

Heavy duty case for tool storage, ideal for the mobile service-engineer. Offers the storage and portability of a large amount of tooling with the professional look of a briefcase. Silver aluminium with reinforced edges and corners. Internal base compartment is fitted with adjustable dividers to offer choice of sizes. Removable rigid tool board stored in the lid with 17 pockets of various sizes. Supplied with fixed handle and two security locks and keys.



Size (mm)	Weight each	Order Code
457 x 330 x 150	3.00kg	SEN-593 -4400K

Executive Engineer's Aluminium Tool Case

Large, lightweight case for tool storage, ideal for the mobile engineer. Offers the storage and portability of a large amount of tooling with the professional look of a briefcase. Black aluminium case with silver reinforced edges and corners. Internal base compartment is fitted with adjustable dividers to offer choice of sizes. Removable rigid tool board stored in the lid with 17 pockets of various sizes. 1" wide, length adjustable lightweight nylon shoulder strap with rubber shoulder protector for added comfort. Supplied with fixed handle and two security locks and keys.



Size (mm)	Weight each	Order Code
457 x 330 x 150	5.70kg	SEN-593 -4360K

HAND TOOLS

Cantilever Aluminium Tool Case

Heavy duty case for tool storage, ideal for the mobile technician. Offers the storage and portability of many tools with the professional look of a briefcase. Silver aluminium with reinforced edges and corners. Concealed cantilever mechanism. Large base compartment with four cantilever trays to make all contents instantly available. Compartment dividers are adjustable to offer choice of sizes. 1" wide, length adjustable lightweight nylon shoulder strap, with rubber shoulder protector for added comfort. Supplied with fixed handle and two security locks and keys.



Size (mm)	Weight each	Order Code
360 x 220 x 245	3.10kg	SEN-593 -4600K

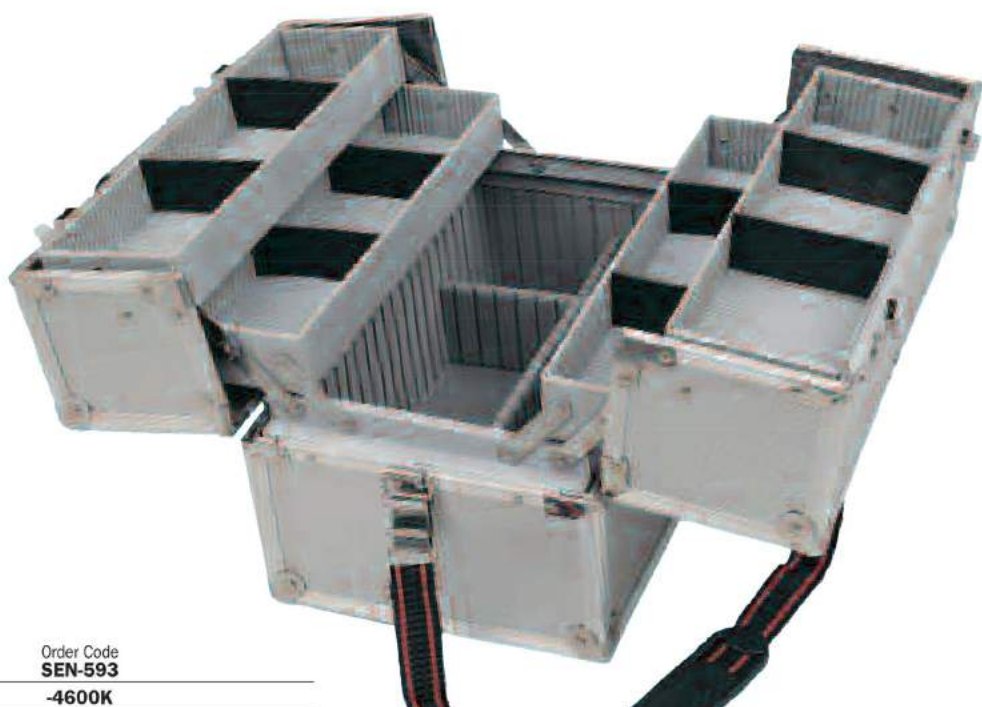

KENNEDY Tote Tool Organisers

Multi-purpose tote tray organisers are an ideal way to store and transport tools. The tote provides two deep trays for storage, built-in tool holders and a ribbed handle for extra grip.

Small: 392 x 281 x 110mm.
Large: 520 x 340 x 200mm.

Tools Not Included

Size	Weight each	Order Code
Small	410g	KEN-593 -2050K
Large	870g	-2070K

KENNEDY Power Tool Case

Sturdy plastic case, suitable for a variety of tools, such as angle grinders, honing machines, drills, planes, sanders, etc.



Size (mm)
420 x 260 x 160

Order Code
KEN-593 -1020K

Steel Tool Tidy

Made from heavy gauge steel with double folded seams. For storing and transporting portable power tools and other items that require an industrial case for protection.



Size (mm)	Weight each	Order Code
270 x 115 x 400	1.40kg	KEN-593 -1000K

PRODUCTS ARE ONLY AVAILABLE VIA YOUR DISTRIBUTOR

GROUP 593 TOOL BOXES

KENNEDY Multi-Utility Storage Box

A lightweight high capacity injection moulded polypropylene box for tough, heavy duty use. Water-resistant design and integral lifting grips on both sides. The lid features a full length steel pin hinge with 'positive pressure' cam style clasping mechanism that seals the case to create a water-resistant closure. Also features integral trolley suit-case style wheels and a pull-out handle, a robust fold flat carry handle and a slide out clear ID/nameplate holder. Shock-resistant and corrosion-proof. Moulded padlocking hasp and stacking locators.



Tools Not Included

Size (mm)	Order Code
780 x 410 x 330mm	KEN-593
	-1600K

HAND TOOLS

4-Drawer Tool Chest

Manufactured from high impact co-polymer polypropylene. Metric graduated V-groove in the lid securely holds workpiece while being cut.

Features

4 sliding drawers enclosed with a slide clasp front panel to prevent opening whilst in transit. Top carry handle with soft touch grip zone and large locking clasps. Front cover panel and lid have aligning padlock hole for added security.



Tools Not Included

Size (mm)	Order Code
450 x 250 x 325	KEN-593
	-1500K

588

PRODUCTS ARE ONLY AVAILABLE VIA YOUR DISTRIBUTOR

© 2018



KENNEDY
QUALITY INDUSTRIAL TOOLING

2-in-1 Rolling Tool Box

Mobile storage solution manufactured from impact resistant plastic, making it ideal for heavy duty use. Features include - soft bi-material handles, padlock eyes, heavy-duty steel catches, side handles for dual lifting, high strength wheels with rubber tyres, integrated footplate to aid tilting, reinforced corners, and lock-in latches to secure the two tool boxes together.

Dimensions (LxWxH):

Small box 560 x 285 x 245mm
Large box 660 x 375 x 445mm



Weight

Order Code
KEN-593

11.3kg

-9810K

lock-in latches to secure the boxes together during transit



Steel Catches

Rubber Tyres

Reinforced Corners



Tools Not Included

GROUP 593



Mobile Tool Cabinet

Manufactured from high impact co-polymer polypropylene. Large tilt opening parts bin. Sliding drawers with locking mechanism to prevent the drawer opening whilst in transit. Top carry handle with soft touch grip zone and large locking clasps. Internal four compartment tote tray. Top box and parts bin both feature aligning holes to suit padlocks with shackle diameters of up to 7.4mm. Metric graduated V-groove in the lid securely holds work piece while being cut. Trolley handle is height adjustable. Rear 'H' hooks for storing extension leads and large wheels for easy movement.



Size (mm)

Order Code
KEN-593

490 x 380 x 720

-1800K

Toolbox with Organisers & Tote Tray

Lightweight reinforced body for added strength and durability.

18" Mobile Toolbox with 8 Organisers & Tote Tray

Made up of 2 stacking toolboxes and including 8 organisers (4 removable with lids) and removable tote tray with handle. Recessed rigid handle with lock mechanism and rubber coated plastic wheels for easy movement.

new



18" Toolbox with 4 Organisers & Tote Tray

Includes 4 removable organisers with lids and removable tote tray with handle. With ergonomic aluminium handle and metal clasps with holes for padlocks. V groove with rule built into the lid.



Description

Size (mm)

Order Code
KEN-593

8 Organisers 495 x 350 x 712

-2800K

4 Organisers 495 x 350 x 445

-2810K

PRODUCTS ARE ONLY AVAILABLE VIA YOUR DISTRIBUTOR

589

HAND TOOLS

KENNEDY PROFESSIONAL

18" Professional Cantilever

Heavy gauge steel with all-welded construction for continuous industrial use. Durable corrosion-resistant two part epoxy powder coat finish. Fully enclosed cantilever mechanism for added security. Quick release lid clasps with padlock hole for security. Two-piece cantilever lids that can be padlocked for additional security (padlock not included). Full width piano hinges provide rigidity and strength. Large base compartment (450 x 260 x 170mm) with four cantilever trays for additional storage. The cantilever action of the top trays makes tray contents instantly available. Supplied with fixed carry handle on the lid.



Width (mm)	Depth (mm)	Height (mm)	Weight each	Order Code
459	255	333	9.10kg	KEN-594 -0140K

Heavy Duty Tool Boxes

Heavy gauge steel, all welded construction. Durable and corrosion resistant two-part epoxy powder paint finish. With quick release lid clasps, padlock hasps and textured carry handles. Full width piano hinges provide rigidity and strength, ensuring smooth operation and additional security. Removable tote tray for smaller tools and components. Can be padlocked for additional security (padlock not included). Supplied with fixed carry handle on the lid.



Width (mm)	Depth (mm)	Height (mm)	Weight each	Order Code
483	180	180	3.65kg	KEN-594 -0040K
508	218	243	6.35kg	-0060K

HAND TOOLS

KENNEDY QUALITY INDUSTRIAL TOOLING

Industrial Cantilever Tool Boxes

Manufactured from industrial quality steel with all welded construction. Durable corrosion-resistant two-part epoxy powder coat finish. Two piece cantilever lids with padlock hole for additional security. Large base compartment with four partitioned, instant access cantilever trays for additional storage.

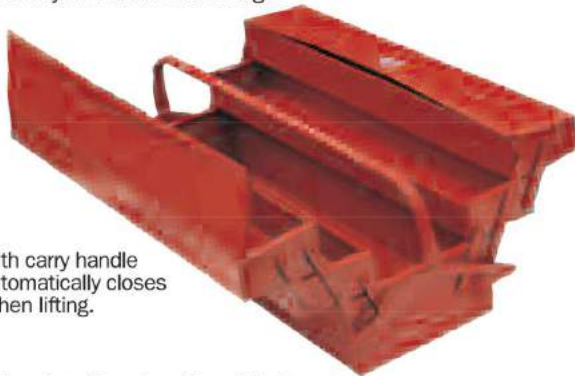

Full width carry handle also automatically closes trays when lifting.

Overall Length	Overall Width	Overall Depth	Weight each	Order Code
430mm	205mm	205mm	5.30kg	KEN-593 -1170K
560mm	205mm	205mm	6.10kg	-1210K

Barn-Type Tool Boxes

Manufactured from heavy gauge steel of rigid construction for continuous industrial use. Large base compartment for larger items and removable tote tray for smaller and most used items. Hard wearing cellulose paint finish. Two piece lid doors that overlap with padlock hole for added security. Full width piano hinges provide rigidity and strength. Supplied with fixed carry handle on the lid.



Overall Length	Overall Width	Overall Depth	Weight each	Order Code
355mm	205mm	185mm	3.00kg	KEN-593 -2140K
480mm	205mm	185mm	4.40kg	-2190K
610mm	205mm	185mm	5.10kg	-2240K

SENATOR QUALITY TOOLING

Cantilever Tool Boxes

Steel construction with two piece cantilever lids with padlock hole for additional security. Large base compartment with four easy access cantilever trays for additional storage. The full width carry handle automatically closes the trays when lifting.



Dimensions LxWxD (mm)	Order Code
430 x 205 x 205	SEN-593 -1370K
530 x 205 x 205	-1410K

Barn-Type Tool Box

Steel construction with base compartment for larger items and removable upper tray for smaller, most used items.



Size (mm)	Order Code
355 (14")	SEN-593 -1540K



YAMOTO Heavy Duty Site Tool Boxes

Powder coated. Soft grip carrying handle and lightweight design. The black plastic overriders add to the overall ruggedness helping to prevent damage to the box or items around it. The lid has 'V' section to allow measuring and cutting short lengths of pipe. There is a tote tray for smaller items. Fitted with heavy-duty metal latches designed to stay closed even when in transit.



Width (mm)	Depth (mm)	Height (mm)	Order Code
470	238	178	-1420K
582	298	255	-1440K
2 Piece Set - (1 of each above)			-1400K

KENNEDY Mobile Tool Box

Sturdy mobile tool box with a large lower storage area for power tools, etc. The tool box has an integral handle slides out for ease of transport, two nested tote trays for smaller tools. The lockable lid has two storage compartments for fixings.



Size (mm)	Order Code
580 x 370 x 480mm	-2000K

Tools Not Included

20" Toolbox with 9 Organisers & Tote Tray

Lightweight reinforced body for added strength and durability. Supplied with 3 removable organisers with lids and 6 organiser compartments built into the lid. Includes removable tote tray with handle.

new



Order Code
KEN-593
-2360K

KENNEDY Tool Box with Tote

Manufactured from impact resistant high-density plastic. Internal eight compartment tote tray. Features moulded metric rule on the lid, lid locking clasps and sturdy plastic handle that also locks lid shut when lifting. Padlock hole and piano hinges.



Size (mm)	Order Code
445 x 240 x 220	KEN-593
	-2300K

Tool Box With Tote & Organiser

Made from impact resistant high-density plastic. Internal eight compartment tote tray with retractable carry handle and stacking 16-compartment organiser, moulded metric scale on the lid, lid locking clasps and sturdy plastic handle that also locks lid shut when lifting. With lock hasp and piano hinges.



Size (mm)	Order Code
480 x 240 x 260	KEN-593
	-2320K

Tool Box with Tote & Wheels

Recessed rigid handle for tilting box onto wheels for easy transportation. Large clasps to lock lid when in transit/storage and padlock hole for security. Recessed carrying handle allows stacking. Five-compartment tote tray also features opaque lids on the two end compartments with moulded snap clasps to prevent accidental opening.

Weight: 3.30kg.



Size (mm)	Order Code
645 x 280 x 300	KEN-593
	-2340K



PRODUCTS ARE ONLY AVAILABLE VIA YOUR DISTRIBUTOR



KENNEDY PROFESSIONAL Roller Cabinets & Tool Chests

Our Ultimate Range of Tool Storage – Combines Maximum Capacity with a Superior Finish

Ultimate in terms of design, materials and manufacture, this range is the perfect choice for the professional whose tools and thinking are state of the art. All units are made from a two part construction with strong steel inner walls and reinforced back panels for added strength and stability. There are angled corners to protect against mobility strains and an anti-rust and solvent resistant powder coat finish. The fully opening drawers have classic design pulls to allow easy access with a drawer weight capacity of 40-45kg.

Excellent Design

- Anti-rust and solvent resistant powder coat finish protects against incidental damage
- Perforated sides optimise space with easy to install accessories and tool holders
- 45° angled corners protect against mobility strains and preserve unit shape
- Plastic bumpers on each corner protect against impact
- Non-slip EVA 3mm drawer liners prevent damage and protect tools
- Fully opening drawers for greater access
- 45mm Ball bearing slides give good drawer stability and smooth action even under load
- Top chest designed to combine with roller cabinet for maximum storage

Increased Mobility

- Strong ergonomic side handles either side of the unit

Greater Security

- Full height rear locking mechanism with cylinder locks for greater security

Enhanced Safety

- Top lid fitted with gas struts for safe and easy access
- 'KISS' (Kennedy Integrated Safety System) allows only one wide drawer to open at a time, preventing tipping

• Total drawer load capacity

Tool Chests: 270kg.

Roller Cabinets:

225-315kg.

Top Chest

6 Drawer Size (WxDxH):

3x 168x398x75mm

3x 568x398x75mm

Roller Cabinets

5 Drawer Size (WxDxH):

1x 568x398x75mm

4x 568x398x154mm

7 Drawer Size (WxDxH):

5x 568x398x75mm

2x 568x398x154mm

Drawer Capacity 45kg
550kg
Static Weight Capacity

Roller Cabinet only



HAND TOOLS

-2140K

-2310K

Accessories
Page 595

Top Chest

Number of Drawers	Width (mm)	Depth (mm)	Height (mm)	Order Code
6	710	465	455	KEN-594 -2240K

Roller Cabinets

Number of Drawers	Width (mm)	Depth (mm)	Height (mm)	Order Code
5	710	465	845	-2140K
7	710	465	845	-2340K



KENNEDY Roller Cabinets & Tool Chests

Our High-end Industrial Range – Modern design that’s sturdy, stylish and secure

This range has been made with the heavy industrial user in mind. It features full width top chests and full height cabinets with alloy style castors. Made from robust steel with inner walls and reinforced back panels, all units are finished with anti-rust and solvent resistant powder coat paint. All corners are angled to maintain product shape and offer cabinet protection during repositioning. This range features fully opening drawers with classic design pulls to allow easy access.

Excellent Design

- Anti-rust and solvent resistant powder coat finish protects against incidental damage
- Perforated sides optimise space with easy to install accessories
- Steel inner walls for added strength and extra rigidity
- Non-slip EVA top mat and liners prevent damage and protect tools
- Fully opening drawers with magnets to secure them in place
- 45mm Ball bearing slides give good drawer stability and smooth action even under load

Greater Security

- Locking system with cylinder locks for added security

Increased Mobility

- Strong ergonomic side handle, which can fit to either side of the unit, facilitate easy repositioning
- 125mm diameter castors with lockable brakes absorb shock and can support heavy loads

Enhanced Safety

- Spring loaded catches prevent drawers opening when repositioning

- **Total drawer load capacity**
Tool Chests - 105-210kg
Roller Cabinets - 105-245kg

Top Chest

3 Drawer Size (WxDxH):
3x 568x398x75mm

6 Drawer Size (WxDxH):
3x 168x398x75mm
3x 568x398x75mm

12 Drawer Size (WxDxH):
9x 168x398x50mm
2x 568x398x50mm
1x 568x398x75mm

Roller Cabinets

3 Drawer Size (WxDxH):
3x 568x398x75mm

5 Drawer Size (WxDxH):
1x 568x398x75mm
4x 568x398x154mm

7 Drawer Size (WxDxH):
5x 568x398x75mm
2x 568x398x154mm

Drawer Capacity 35kg
450kg
Static Weight Capacity

Roller Cabinet only



HAND TOOLS

Top Chests

Number of Drawers	Width (mm)	Depth (mm)	Height (mm)	Order Code
3	710	465	375	-2040K
6	710	465	455	-2220K
12	710	465	485	-2420K

Accessories Page 595

Roller Cabinets

Number of Drawers	Width (mm)	Depth (mm)	Height (mm)	Order Code
3	710	465	845	-2020K
5	710	465	845	-2120K
7	710	465	845	-2320K

PRODUCTS ARE ONLY AVAILABLE VIA YOUR DISTRIBUTOR

KENNEDY
PROFESSIONAL
Mobile
Workstation
Ultimate Range 10 Drawer Workstation

Part of our Ultimate Range which combines robust performance with stylish appearance and superior finish. Steel construction with 45mm ball bearing drawer slides and steel side handles. Anti-rust and solvent resistant powder coat finish. Quick lock function to prevent unwanted opening of drawers. Perforated sides for hanging accessories. Fitted with 2 x fixed castors and 2 x swivel castors with full brakes.

Max drawer load: 45kg.

Number of Drawers	Width (mm)	Depth (mm)	Height (mm)	Order Code
10	1123	791	844	KEN-594 -6800K

KENNEDY 36" Drawer Cabinet
QUALITY INDUSTRIAL TOOLING with Side Lockers

Our High-end Industrial Range – Robust Enough for the Demands of Every Workplace

Modern design that's sturdy, stylish and secure

This range has been made with the heavy industrial user in mind. It features full width top chests and full height cabinets with alloy style castors. Made from robust steel with inner walls and reinforced back panels, all units are finished with anti-rust and solvent resistant powder coat paint. All corners are angled to maintain product shape and offer cabinet protection during repositioning. This range features fully opening drawers with classic design pulls to allow easy access

Excellent Design

- Extra wide Roller Cabinet with larger top surface and additional storage in lockable side cupboards which are complete with gas struts
- Anti-rust and solvent resistant powder coat finish protects against incidental damage
- Perforated sides optimise space with easy to install accessories
- Steel inner walls for added strength and extra rigidity
- Non-slip EVA 10mm top mat and 2.5mm liners prevent damage and protect tools
- Fully opening drawers with magnets to secure them in place
- 45mm Ball bearing slides give good drawer stability and smooth action even under load
- Side lockers open out to offer additional secure storage

Greater Security

- Locking system with cylinder locks for added security

Enhanced Safety

- Spring loaded catches prevent drawers opening when repositioning
- Gas Struts on side cabinets

Increased Mobility

- Strong ergonomic side handle, which can fit to either side of the unit, facilitates easy repositioning
- 125mm diameter castors with brakes absorb shock and can support heavy loads

5 Drawer Roller Cabinet

 1@ 568 x 398 x 75mm
 4@ 570 x 400 x 155mm

Drawer
Capacity 35kg
450kg
Static Weight
Capacity

Roller Cabinet only

Number of Drawers	Width (mm)	Depth (mm)	Height (mm)	Order Code
5	907	474	815	KEN-594 -2620K

Accessories

320mm Paper Roll Holder
Size: (WxDxH) 20x30x270mm



Multifunctional Tray
Size: (WxDxH) 320x90x120mm



ABS Work Top Tray
Size: (WxDxH) 720x470x25mm



7 Piece Hook Rack
Size: (WxDxH) 325x5x29mm



Side Tray
Size: (WxDxH) 300x120x60mm



4 Piece Can Holder
Size: (WxDxH) 325x90x70mm



7 Piece Screwdriver Holder
Size: (WxDxH) 200x39x65mm



Waste Bin
Size: (WxDxH) 300x135x250mm



Tote Tray
Size (WxDxH): 440 x 175 x 85mm

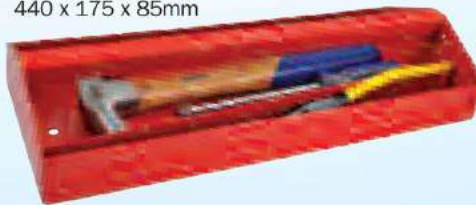

Description	Order Code KEN-594
Paper Roll Holder	-1560K
ABS Work Top Tray	-1580K
4 Piece Can Holder	-1590K
7 Piece Hook Rack	-1610K
7 Piece Screwdriver Holder	-1630K
Tote Tray	-1640K
Multifunctional Tray	-1650K
Side Tray	-1660K
Waste Bin	-1670K

KENNEDY PROFESSIONAL Portable Tool Chests

Manufactured from heavy gauge steel with all welded construction. Durable and corrosion-resistant two part epoxy powder paint finish. With quick release lid clasps, padlock hasps and textured carry handles. Full width piano hinges provide rigidity and strength, ensuring smooth operation and additional security.

2 Drawer

Two full-length drawers with rigid aluminium lipped handles. Automatically locks the drawers when the lid is closed, to prevent accidental opening.

Drawer size:
508 x 190 x 76mm.



3 Drawer

Three full-length drawers with rigid aluminium edged handles. Fully lockable unit with a handle on the top and a carry handle on each end. The lid automatically locks all of the closed drawers when lowered to prevent opening.

Overall dimensions (W x H x D):
520 x 340 x 215mm.

Drawer sizes:
2@ 460 x 180 x 55mm.
1@ 460 x 180 x 75mm.



Number of Drawers	Width (mm)	Depth (mm)	Height (mm)	Weight each	Order Code KEN-594
2	534	218	288	10.4kg	-0100K
3	520	215	340	10.4kg	-0120K

Stainless Steel Roller Cabinet

Manufactured from heavy gauge grade 304 stainless steel with double wall construction side panels and welded joints for added rigidity. Quick release smooth running ball bearing drawer slides. Fully locking. 125 x 50mm heavy-duty extra strong castors, fitted with two brakes. Castors are rated to 100kg capacity standing load per castor. Drawer loads should be evenly distributed.



7 Drawer Roller Cabinets

Drawer sizes (W x D x H):
5@ 597 x 428 x 90mm.
1@ 597 x 428 x 135mm.
1@ 597 x 428 x 180mm.
Overall dimensions:
683 x 480 x 887mm.

Spares	Order Code
Lock	SPR-567-7210K
Key Blank	SPR-567-7320K
Draw Slide	SPR-567-7040K
Castors	SPR-567-6920K
Top Mat	SPR-567-7540K
Draw Liner	SPR-567-6610K

For Prices see Page 605

Order Code
KEN-594
-6020K

KENNEDY PROFESSIONAL Step-up Units

2 Drawer

Manufactured from heavy gauge steel, electro-coated enamel finish for superior appearance and protection. Steel panels in the drawers for extra rigidity, ball bearing drawer runners. Supplied with drawer liners and top mat.

Drawer sizes (W x D x H):

2@ 590.5 x 410 x 102mm.



Spares	Order Code
Lock	SPR-567-7210K
Key Blank	SPR-567-7320K
Draw Slide	SPR-567-7040K
Top Mat	SPR-567-7560K
Draw Liner	SPR-567-6610K

For Prices see Page 605

Colour	Width (mm)	Depth (mm)	Height (mm)	Weight each	Order Code
Red	688	459	280	44.0kg	-5400K

Tool Chests

3 Drawer

Top compartment size:

90 x 660 x 150mm.

Drawer sizes (W x D x H):

1@ 590 x 285 x 50mm.
2@ 590 x 285 x 100mm.



Spares	Order Code
Lock	SPR-567-7240K
Key Blank	SPR-567-7320K
Draw Slide	SPR-567-7000K
Lid Stays	SPR-567-6950K
Draw Liner	SPR-567-6610K

For Prices see Page 605

Colour	Width (mm)	Depth (mm)	Height (mm)	Weight each	Order Code
Red	690	315	385	44.0kg	-5200K

6 Drawer

Top compartment size:

660 x 150 x 90mm.

Drawer sizes (W x D x H):

2@ 125 x 285 x 50mm.
1@ 280 x 285 x 50mm.
2@ 590 x 285 x 50mm.
1@ 590 x 285 x 100mm.



Spares	Order Code
Lock	SPR-567-7240K
Key Blank	SPR-567-7320K
Draw Slide	SPR-567-7060K
Lid Stays	SPR-567-6960K
Draw Liner	SPR-567-6610K

For Prices see Page 605

Colour	Width (mm)	Depth (mm)	Height (mm)	Weight each	Order Code
Red	690	315	385	44.0kg	-5240K

12 Drawer

Top compartment size (W x D x H):
660 x 150 x 90mm.

Drawer sizes (W x D x H):

6@ 125 x 410 x 50mm.
1@ 170 x 410 x 155mm.
2@ 130 x 410 x 75mm.
2@ 590 x 410 x 50mm.
1@ 590 x 410 x 100mm.

Uses 14" drawer slides.
Type B lid stays.



EXTRA DEEP

Spares	Order Code
Lock	SPR-567-7240K
Key Blank	SPR-567-7320K
Draw Slide	SPR-567-7040K
Lid Stays	SPR-567-6950K
Draw Liner	SPR-567-6610K

For Prices see Page 605

Colour	Width (mm)	Depth (mm)	Height (mm)	Weight each	Order Code
Red	690	445	490	48.0kg	-5280K

Extra Deep Tool Chests

5 Drawer

Over 25% deeper than standard size tool chests for extra storage.

Drawer sizes (W x D x H):

3@ 595 x 405 x 50mm.
2@ 595 x 405 x 100mm.

Uses 14" drawer slides.
Type B lid stays.



EXTRA DEEP

Spares	Order Code
Lock	SPR-567-7240K
Key Blank	SPR-567-7320K
Draw Slide	SPR-567-7060K
Lid Stays	SPR-567-6960K
Draw Liner	SPR-567-6610K

For Prices see Page 605

Colour	Width (mm)	Depth (mm)	Height (mm)	Weight each	Order Code
Red	660	405	510	34.0kg	-5340K

9 Drawer

Over 25% deeper than standard size tool chests for extra storage.

Drawer sizes (W x D x H):

6@ 295 x 405 x 50mm.
2@ 595 x 405 x 50mm.
1@ 595 x 405 x 100mm.

Uses 14" drawer slides.
Type B lid stays.



EXTRA DEEP

Spares	Order Code
Lock	SPR-567-7240K
Key Blank	SPR-567-7320K
Draw Slide	SPR-567-7060K
Lid Stays	SPR-567-6960K
Draw Liner	SPR-567-6610K

For Prices see Page 605

Colour	Width (mm)	Depth (mm)	Height (mm)	Weight each	Order Code
Red	660	405	510	41.0kg	-5360K



KENNEDY PROFESSIONAL Roller Cabinets

Manufactured from heavy gauge steel with double wall construction side panels and welded joints for added rigidity. Coated in a hard wearing epoxy powder. Fully opening drawers for extra accessibility. Quick release smooth running ball bearing drawer slides with double sliders on base drawer. Supplied with top mat and drawer liners. Fully locking. 125 x 50mm heavy-duty extra strong castors, fitted with two brakes. Overall dimensions: 890 x 690 x 460mm. Castors are rated to 100kg capacity standing load per castor. Drawer loads should be evenly distributed. Roller cabinets are not suitable for frequent relocation when loaded, and when moved should only ever be pushed.

3 Drawer

Internal drawer dimensions bottom compartment (W x D x H):
610 x 430 x 355mm.

Drawers (W x D x H):
3@ 590 x 410 x 100mm.
Uses 16" drawer slides.



Spares	Order Code
Lock	SPR-567-7260K
Key Blank	SPR-567-7320K
Draw Slide	SPR-567-7040K
Castors	SPR-567-6920K
Top Mat	SPR-567-7560K
Draw Liner	SPR-567-6610K

For Prices see Page 605

Colour	Width (mm)	Depth (mm)	Height (mm)	Weight each	Order Code KEN-594
Red	690	460	890	44.0kg	-5500K
Green					-5510K

5 Drawer

Drawers (W x D x H):
4@ 590 x 410 x 100mm.
1@ 590 x 410 x 200mm.

Uses 16" drawer slides.



Spares	Order Code
Lock	SPR-567-7210K
Key Blank	SPR-567-7320K
Draw Slide	SPR-567-7040K
Castors	SPR-567-6920K
Top Mat	SPR-567-7560K
Draw Liner	SPR-567-6610K

For Prices see Page 605

Colour	Width (mm)	Depth (mm)	Height (mm)	Weight each	Order Code KEN-594
Red	690	460	890	44.0kg	-5540K
Green					-5550K

7 Drawer

Drawers (W x D x H):
4@ 590 x 410 x 50mm. 2@ 590 x 410 x 100mm.
1@ 590 x 410 x 200mm.

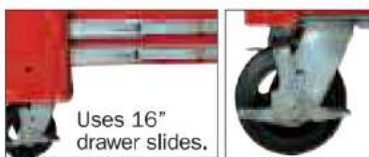

Heavy-duty extra strong castors

Spares	Order Code
Lock	SPR-567-7210K
Key Blank	SPR-567-7320K
Draw Slide	SPR-567-7040K
Castors	SPR-567-6920K
Top Mat	SPR-567-7560K
Draw Liner	SPR-567-6610K

For Prices see Page 605



Colour	Width (mm)	Depth (mm)	Height (mm)	Weight each	Order Code KEN-594
Red	690	460	890	53.0kg	-5580K
Green					-5590K

ABS Worktop to suit Standard Roller Cabinets

Designed to fit directly on to the top of most standard 3, 5, and 7 drawer roller cabinets including Kennedy, Yamoto, Senator, Britool, Proto etc. Provides a non-slip compartmentalised working space to hold tools and fasteners whilst protecting the paint finish of the roller cabinet itself. Manufactured from high impact ABS plastic.

Overall size (W x D): 695mm x 464mm
Size range of cabinets suited (W x D): 655mm to 690mm x 425mm to 460mm



Overall Size (mm)	Min/Max Width (mm)	Min/Max Depth (mm)	Order Code SPR-567
695 x 464	655/690	425/460	-6840K

PRODUCTS ARE ONLY AVAILABLE VIA YOUR DISTRIBUTOR



KENNEDY PROFESSIONAL

Extra Deep, Heavy Duty Tool Chest

4 Drawer + Top Compartment

Heavy gauge steel, welded and riveted to form an extremely rigid construction. The two part epoxy powder paint finish gives excellent corrosion-resistance and ensures durability. Central locking system. A full width piano hinge provides rigidity, strength and additional security. The drawers have smooth running ball bearing slides and each has its own safety catch. The four full-length drawers have rigid aluminium edged handles and are sized:

Drawer sizes (W x D x H):

2@ 560 x 340 x 40mm. 1@ 560 x 340 x 65mm.
1@ 560 x 340 x 95mm.



Spares

- Lock SPR-567-7240K
- Key Blank SPR-567-7320K
- Draw Slides SPR-567-7060K
- Lid Stays SPR-567-4820K
- Draw Liner SPR-567-6610K
- Lock Link SPR-567-7410K

For Prices see Page 605

Lock Links to suit Extra Heavy-Duty Chests & Cabinets

To suit Cabinet/Chest (Order Code)	Order Code
KEN-594-4820K	-7400K
KEN-594-4860K	

Extra Deep, Extra Large, Heavy-Duty Tool Chest

9 Drawer + Top Compartment

Heavy gauge steel, welded and riveted to form this extra large chest. Corrosion resistant powder coated finish provides superb durability. Locking mechanism locks all drawers as the lid is closed and each drawer has its own safety catch. Four heavy-duty type carry handles with comfortable grips for easier lifting. The lid has a full width piano hinge giving extra rigidity, strength and additional security. Drawers have smooth running ball bearing drawer slides and rigid aluminium edged handles.

Drawer sizes (W x D x H):

2@ 560 x 340 x 40mm. 2@ 305 x 340 x 40mm.
2@ 560 x 340 x 65mm. 1@ 305 x 340 x 65mm.
1@ 560 x 340 x 95mm. 1@ 305 x 340 x 180mm.



Width (mm)	Depth (mm)	Height (mm)	Weight each	Order Code
700	405	450	35.5kg	-4820K

Width (mm)	Depth (mm)	Height (mm)	Weight each	Order Code
1050	405	530	68kg	-4860K

Features of our XD & XDXL Range



HD Castors HD Side Handle Checker-plate Top Gas Strut HD Chest Handles Individual Catches Ball Bearing Slides

Extra Deep, Heavy Duty Roller Cabinet

7 Drawer

Heavy gauge steel, welded and riveted to give an extremely rigid construction. Corrosion resistant powder coated finish. Locking mechanism locks all the closed drawers which have individual safety catches to prevent accidental opening. Four heavy-duty castors, two fixed and two swivel which when combined with the heavy-duty side handle enable the user to move it with ease. All drawers have smooth running ball bearing drawer slides and aluminium edged handles.

Drawer sizes (W x D x H):

1@ 570 x 393 x 52mm.
4@ 570 x 393 x 80mm.
1@ 570 x 393 x 108mm.
1@ 570 x 393 x 154mm.



Spares

- Lock SPR-567-7210K
- Key Blank SPR-567-7320K
- Draw Slides SPR-567-7040K
- Castor's SPR-567-6910K
- Draw Liner SPR-567-6610K
- Lock Link SPR-567-7410K

For Prices see Page 605

Lock Links to suit Extra Heavy-Duty Chests & Cabinets

To suit Cabinet/Chest (Order Code)	Order Code
KEN-594-4840K	-7410K

Width (mm)	Depth (mm)	Height (mm)	Weight each	Order Code
690	460	995	71.5kg	-4840K

Extra Deep, Extra Large, Heavy Duty Roller Cabinet

13 Drawer

Heavy gauge steel, welded and riveted to give extremely rigid construction. The two-part epoxy powder paint finish gives excellent corrosion resistance and ensures durability. Central locking system. Heavy-duty castors and side handle designed to cope with the extra large size and weight. Drawers have smooth running ball bearing drawer slides and rigid aluminium edged handles.

Drawer sizes (W x D x H):

2@ 560 x 390 x 95mm. 1@ 305 x 390 x 95mm.
4@ 560 x 390 x 65mm. 3@ 305 x 390 x 65mm.
1@ 560 x 390 x 205mm. 1@ 305 x 390 x 180mm.
1@ 305 x 390 x 205mm.



Lock Links to suit Extra Heavy-Duty Chests & Cabinets

To suit Cabinet/Chest (Order Code)	Order Code
KEN-594-4880K	-7410K

Width (mm)	Depth (mm)	Height (mm)	Weight each	Order Code
1065	460	1052	119.5kg	-4880K



KENNEDY PROFESSIONAL Extra Large Tool Chests & Roller Cabinets

Manufactured from heavy gauge steel with double wall construction side panels and welded joints for added rigidity. Coated in a hard wearing epoxy powder. Fully opening drawers for extra accessibility. Quick release smooth running ball bearing drawer slides. Supplied with top mat and drawer liners. Fully locking. 125 x 50mm heavy duty extra strong castors, fitted with two brakes. Castors are rated to 100kg capacity standing load per castor. Drawer loads should be evenly distributed. Roller cabinets are not suitable for frequent relocation when loaded and should only ever be pushed.

11 Drawer Top Chest

Top compartment (W x D x H): 1020 x 390 x 100mm.

Drawer sizes (W x D x H):

5@ 580 x 415 x 50mm. 1@ 580 x 415 x 100mm.
4@ 270 x 415 x 50mm. 1@ 270 x 415 x 150mm.



Spares	Order Code
Lock	SPR-567-7240K
Key Blank	SPR-567-7320K
Draw Slide	SPR-567-7040K
Lid Stays	SPR-567-6970K
Top Mat	SPR-567-6780K
Draw Liner	SPR-567-6610K

For Prices see Page 605

Colour	Width (mm)	Depth (mm)	Height (mm)	Weight each	Order Code
Red	1030	460	530	94.0kg	-5780K

EXTRA LARGE

11 Drawer Roller Cabinet

Drawer sizes (W x D x H):

4@ 270 x 415 x 50mm.
4@ 560 x 415 x 50mm.
2@ 560 x 415 x 100mm.
1@ 560 x 415 x 170mm.

Uses 14" drawer slides.
Type B lid stays.



Spares	Order Code
Lock	SPR-567-7210K
Key Blank	SPR-567-7320K
Draw Slide	SPR-567-7040K
Castor's	SPR-567-6920K
Top Mat	SPR-567-7540K
Draw Liner	SPR-567-6610K

For Prices see Page 605

Colour	Width (mm)	Depth (mm)	Height (mm)	Weight each	Order Code
Red	680	480	1130	83.0kg	-5740K

EXTRA LARGE

7 Drawer Roller Cabinet

Internal drawer dimensions

Bottom compartment (W x D x H):

400 x 460 x 300mm.
400 x 460 x 415mm

Drawer sizes (W x D x H):

4@ 580 x 415 x 50mm. 2@ 580 x 415 x 100mm. 1@ 580 x 415 x 150mm.

Uses 14" drawer slides.
Type B lid stays.



EXTRA LARGE

Spares	Order Code
Lock	SPR-567-7260K
Key Blank	SPR-567-7320K
Draw Slide	SPR-567-7040K
Castor's	SPR-567-6920K
Top Mat	SPR-567-7520K
Draw Liner	SPR-567-6610K

For Prices see Page 605

Colour	Width (mm)	Depth (mm)	Height (mm)	Weight each	Order Code
Red	1060	480	925	81.0kg	-5700K

Magnetic Tool Tray

Steel tool/parts tray with durable hardwearing corrosion-resistant powder coated finish. Suitable for keeping small parts, components and tools near to hand when working on vehicles, domestic appliances and other equipment. Three high strength magnets in protective non-scratch rubber coating.



Length x Width x Depth (mm)	Weight each	Order Code
210 x 115 x 115	739g	-6500K
310 x 115 x 115	939g	-6520K

PRODUCTS ARE ONLY AVAILABLE VIA YOUR DISTRIBUTOR



YAMOTO Roller Cabinets
& Tool Chests

Trade Range - Robust enough for the demands of every workplace

Featuring full height cabinets and sturdy tool chests, this mid-range combines modern design with high quality manufacture and is ideal for medium and small manufacturing environments. All products in the range have steel inner walls with a pressed steel back strengthener and angled front corners to prolong cabinet life. The range also features ergonomic drawer pulls with 35mm ball bearing slides which provide smooth action and easy access to tools.

Quality Design

- Anti-rust and solvent resistant powder coat finish protects against incidental damage
- 45° angled front corners protect during repositioning and prolong life of the unit
- Pressed steel back strengthener and inner walls give added strength and longevity
- Reinforced top lid and top chest corner protectors safeguard against impact
- Non-slip EVA 5mm top mat and 2.5mm liners prevent damage and protect tools
- Drawers with magnets to secure them in place
- 35mm Ball bearing slides give good drawer stability and smooth action even under load

Increased Mobility

- Cabinets have strong oval ergonomic handles which fit to either side of unit
- 125mm diameter castors with 2x brakes absorb shock and can support heavy loads

Built-in Safety

- Lockable steel stays prevent reinforced lid accidentally slamming shut

Added Security

- Locking system complete with cylinder locks and 2 keys for added security

Total drawer load capacity

Tool Chests - **150-180kg**

Roller Cabinets - **90-210kg**

Top Chest

6 Drawer Size (WxDxH):

- 3x 168x275x50mm
- 2x 568x275x50mm
- 1x 568x275x75mm

12 Drawer Size (WxDxH):

- 9x 169x400x50mm
- 2x 568x400x50mm
- 1x 568x400x75mm

Roller Cabinets

3 Drawer Size (WxDxH):

- 2x 568x398x75mm
- 4x 568x398x154mm

5 Drawer Size (WxDxH):

- 1x 568x398x75mm
- 4x 568x398x154mm

7 Drawer Size (WxDxH):

- 5x 568x398x75mm
- 2x 568x398x154mm

**Drawer
Capacity 30kg
400kg
Static Weight
Capacity**

Roller Cabinet only



HAND TOOLS

Top Chests

Number of Drawers	Width (mm)	Depth (mm)	Height (mm)	Order Code
6	660	310	380	-1500K
12	660	440	490	-1520K

Roller Cabinets

Number of Drawers	Width (mm)	Depth (mm)	Height (mm)	Order Code
3	680	460	860	-1600K
5	680	460	860	-1620K
7	680	460	860	-1640K

600

PRODUCTS ARE ONLY AVAILABLE VIA YOUR DISTRIBUTOR

© 2018



YAMOTO Tool Chest

6 Drawer Tool Chest

Made from 0.8mm steel panels with 0.6mm drawers. Powder coated yellow/grey with aluminium drawer pulls. The fully locking lid encloses the six drawers which have foam liners and smooth running 250mm ball bearing drawer slides. Supplied with a loose tote tray for carrying tools to work area.

Overall dimensions (W x D x H): 668 x 315 x 389mm.

Top compartment (W x D x H): 660 x 305 x 50mm.

Tote tray (W x D x H): 430 x 170 x 45mm.

Drawer sizes (W x D x H):

@ 590 x 279 x 101.5mm.

2@ 590 x 279 x 49mm.

1@ 281 x 279 x 49mm.

2@ 127 x 279 x 49mm.



Spares Order Code

Lock	SPR-567-7240K
Key Blank	SPR-567-7320K
Draw Slide	SPR-567-7000K
Lid Stays	SPR-567-6950K
Draw Liner	SPR-567-6610K

For Prices see Page 605



Colour	Width (mm)	Depth (mm)	Height (mm)	Weight each	Order Code
Yellow	668	315	389	22.2kg	-5240K

Roller Cabinet

7 Drawer Roller Cabinet

Body made from 1mm steel panels with 0.8mm drawers. Powder coated yellow/grey with aluminium drawer pulls. Fully opening drawers. Smooth running 350mm ball bearing drawer slides. Rubber top mat and foam drawer liners. Fully locking. 100 x 25mm heavy duty castors, with two brakes. Strong 450mm wide handle.

Overall dimensions (W x D x H):

689 (760 with handle) x 459 x 780mm (915 with castors).

Drawer sizes (W x D x H):

4@ 590 x 409 x 49mm.

2@ 590 x 409 x 101.5mm.

1@ 590 x 409 x 206.5mm.



Spares Order Code

Lock	SPR-567-7180K
Key Blank	SPR-567-7340K
Draw Slide	SPR-567-7100K
Castors	SPR-567-6930K
Top Mat	SPR-567-7560K
Draw Liner	SPR-567-6610K

For Prices see Page 605



Colour	Width (mm)	Depth (mm)	Height (mm)	Weight each	Order Code
Yellow	689	459	780	48.9kg	-5580K



ROLLER CABINETS & TOOL CHESTS

GROUP 594

Tool Chests

Double thickness side walls. One piece drawer slides. Epoxy powder coated finish. Carry handles. All steel construction. Supplied with drawer liners. Piano hinge and lid stays. Supplied with tote tray.

Spares	Order Code
Lock	SPR-567-7240K
Key Blank	SPR-567-7320K
Draw Slide	SPR-567-7020K
Lid Stays	SPR-567-6950K
Draw Liner	SPR-567-6610K

For Prices see Page 605

3 Drawer

Drawer sizes (W x D x H):

1@ 590 x 285 x 50mm.

2@ 590 x 285 x 100mm.

Top compartment size (W x D x H):

660 x 150 x 90mm.

Uses 10"

Drawer slides.

Type A lid stays.



Colour	Width (mm)	Depth (mm)	Height (mm)	Weight each	Order Code
Red	670	315	385	27kg	-0200K

6 Drawer

Drawer sizes (W x D x H):

2@ 130 x 285 x 50mm.

1@ 280 x 285 x 50mm.

2@ 590 x 285 x 50mm.

1@ 590 x 285 x 100mm.

Top compartment size (W x D x H):

660 x 150 x 90mm.

Uses 10" drawer slides.

Type A lid stays.



Colour	Width (mm)	Depth (mm)	Height (mm)	Weight each	Order Code
Red	670	315	385	27kg	-0240K

12 Drawer

Drawer sizes (W x D x H):

8@ 130 x 410 x 50mm.

1@ 280 x 410 x 100mm.

2@ 590 x 410 x 50mm.

1@ 590 x 410 x 100mm.

Top compartment size (W x D x H):

660 x 150 x 90mm.

Uses 10" drawer slides.

Type A lid stays.



Colour	Width (mm)	Depth (mm)	Height (mm)	Weight each	Order Code
Red	670	445	490	47kg	-0280K

HAND TOOLS

PRODUCTS ARE ONLY AVAILABLE VIA YOUR DISTRIBUTOR



YAMOTO Roller Cabinets

Double wall side panels and welded joints for added rigidity. Solid one piece I-beam drawer slides with double sliders on base drawer. Supplied with top mat and drawer liners. Fully locking. 100mm rubber castors, two brakes. Drawer loads should be evenly distributed. Roller cabinets are not suitable for frequent relocation when loaded, and should only ever be pushed.

Spares	Order Code
Lock	SPR-567-7210K
Key Blank	SPR-567-7320K
Draw Slide	SPR-567-7050K
Castors	SPR-567-6900K
Top Mat	SPR-567-7560K
Draw Liner	SPR-567-6610K

For Prices see Page 605

3 Drawer
Overall dimensions (W x D x H):
 690 x 460 x 850mm.
Bottom compartment (W x D x H):
 610 x 430 x 355mm.
Drawer sizes (W x D x H):
 3@ 590 x 410 x 100mm.
 Uses 16" drawer slides.



Colour	Weight each	Order Code
Red	43.0kg	YMT-594 -0500K

5 Drawer
Overall dimensions (W x D x H):
 690 x 460 x 850mm.
Internal drawer dimensions (W x D x H):
 4@ 590 x 410 x 100mm.
 1@ 590 x 410 x 200mm.
 Uses 16" drawer slides.



Colour	Weight each	Order Code
Red	46.5kg	YMT-594 -0540K

7 Drawer
Overall dimensions (W x D x H):
 690 x 460 x 850mm.
Internal drawer dimensions (W x D x H):
 4@ 590 x 410 x 50mm.
 2@ 590 x 410 x 100mm.
 1@ 590 x 410 x 200mm.
 Uses 16" drawer slides.



Colour	Weight each	Order Code
Red	52.5 kg	YMT-594 -0580K

HAND TOOLS

4-Drawer Service Cart

Industrial all steel construction with a Hi-Vis yellow and grey spray paint finish. Full width piano hinge. Chrome oval handle for comfort. Double extending ball bearing drawer runners for full drawer depth opening and smooth operation. 4x 4" solid rubber castors with 360° rotation. Two rear castors feature lever locking mechanism to reduce unwanted movement. Large open base bay. Lid stays to hold the lid in a vertical position when in use. Protective drawer liners prevent scratching and reduce tool noise. Double locking system: Drawer lever locking mechanism within top tool bay. Key locking drop down lid for the top tool bay. Supplied flat packed for on-site assembly.



2 drawers (W x H x D Internal):
 300 x 70 x 440mm.

2 drawers (W x H x D Internal):
 640 x 70 x 440mm.

Maximum capacities:

Drawers:
 40kg/drawer.
Overall: 280kg.

Top tool bay:
 675 x 450mm storage.
 2x 35 x 470mm tool storage.



Overall Width	Overall Depth	Overall Height	Weight each	Order Code
660mm	500mm	960mm	53.0kg	YMT-594 -2040K
Description				Order Code
Replacement 90° Lock Set				YMT-567 -6800K
Replacement Drawer Sliders (Pr)				-7100K



SENATOR Roller Cabinets
QUALITY TOOLING Tool Chests

Our Workshop, General Purpose Range – Entry Level Choice for Durability and Mobility

- Workshop range of roller cabinets and top chests is an ideal entry level choice for small manufacturers, garages and one man businesses
- Anti-rust and solvent resistant powder coat finish protects paintwork
- Pressed steel back strengthener and inner walls give added strength and longevity
- Non-slip EVA 5mm top mat and 2.5mm liners prevent damage and protect tools
- Firm return secures drawer in place
- Ball bearing slides give good drawer stability and smooth action even under load
- Cabinets have strong ergonomic handles which can fit to either side of unit
- 100mm diameter castors with brakes absorb shock and can support heavy loads
- Locking system with cylinder locks for added security
- Drawer Load: 25kg
- Static Load: 300kg
- Combine a Roller Cabinet + Top Chest for the total storage solution

• **Total drawer load capacity**
Tool Chests - **75kg - 120kg**
Roller Cabinets - **125 - 175kg**

Drawer Capacity 25kg
300kg
Static Weight Capacity

Roller Cabinet only

Roller Cabinets

3 Drawer Size (WxDxH):

3x 568x398x60mm

5 Drawer Size (WxDxH):

1x 561x398x60mm

4x 568x398x124mm

7 Drawer Size (WxDxH):

5x 568x398x60mm

2x 568x398x124mm

Top Chest

3 Drawer Size (WxDxH):

3x 568x272x50mm

6 Drawer Size (WxDxH):

3x 168x272x50mm

6x 568x272x50mm

-1570K

-1660K

-1550K

-1530K

Step-up Unit

Top Chest

HAND TOOLS

Step-up Unit

Number of Drawers	Width (mm)	Depth (mm)	Height (mm)	Order Code
3	667	370	270	SEN-594
				-1800K

Top Chest

Number of Drawers	Width (mm)	Depth (mm)	Height (mm)	Order Code
6	660	310	355	SEN-594
				-1660K

Roller Cabinets

Number of Drawers	Width (mm)	Depth (mm)	Height (mm)	Order Code
3	680	460	725	-1530K
5	680	460	725	-1550K
7	680	460	725	-1570K

PRODUCTS ARE ONLY AVAILABLE VIA YOUR DISTRIBUTOR

SENATOR
QUALITY TOOLING

Tool Chest

6 Drawer

Body made from 0.8mm steel panels with 0.6mm drawers. Powder coated finish in blue/grey with aluminium drawer pulls. The fully locking fold down lid encloses the six drawers which have foam liners and smooth running 250mm ball bearing drawer slides. Supplied with a loose tote tray. Chrome carrying handles.



Ball Bearing Drawer Slides

Overall dimensions (W x D x H): 668 x 315 x 389mm.

Top compartment (W x D x H): 660 x 305 x 50mm.

Tote tray (W x D x H): 430 x 170 x 45mm.

Drawer sizes (W x D x H):
1@ 590 x 279 x 101.5mm,
2@ 590 x 279 x 49mm,
1@ 81 x 279 x 49mm,
2@ 127 x 279 x 49mm.



Colour	Width (mm)	Depth (mm)	Height (mm)	Weight each	Order Code
Blue	668	315	389	22.9kg	SEN-594 -5240K

Roller Cabinet

7 Drawer

Body made from 1mm steel panels with 0.8mm drawers. Powder coated finish in blue/grey with aluminium drawer pulls. Fully opening drawers for extra accessibility. Quick release smooth running 350mm ball bearing drawer slides. Rubber top mat and foam drawer liners. Fully locking. 100 x 25mm heavy duty castors, fitted with two brakes. Strong 450mm wide handle. Drawer loads should be evenly distributed. Roller cabinets should only be pushed.

Overall dimensions (W x D x H): 689 - 760 with handle x 459 x 780mm - 915 with castors.

Drawer sizes (W x D x H): 4@ 590 x 409 x 49mm, 2@ 590 x 409 x 101.5mm, 1@ 590 x 409 x 206.5mm.



Ball Bearing Drawer Slides

Colour	Width (mm)	Depth (mm)	Height (mm)	Weight each	Order Code
Blue	689	459	780	48.9kg	SEN-594 -5580K

Tool Chests

For the cost conscious, DIY and light industrial use.

3 Drawer

Piano hinged lid. Carry handle. Cantilever top tray. Fully locking.

Drawer sizes (W x D x H): 3@ 450 x 190 x 55mm. Uses 10" drawer slides. Type A lid stays.



Spares
Lock SPR-567-7200K
Key Blank SPR-567-7300K
Draw Slide SPR-567-7020K
Draw Liner SPR-567-6610K

For Prices see Page 605

Colour	Width (mm)	Depth (mm)	Height (mm)	Weight each	Order Code
Red	520	218	304	9.1kg	SEN-594 -0200K

6 Drawer

Piano hinge. Carry handles. Tote tray. Fully locking. Two wall construction side panels. I-Beam draw slides.

Drawer sizes (W x D x H): 2@ 50 x 125 x 280mm, 1@ 50 x 280 x 280mm, 2@ 50 x 590 x 280mm, 1@ 100 x 590 x 280mm.

Uses 10" drawer slides. Type A lid stays.

Spares
Lock SPR567-7240K
Key Blank SPR567-7320K
Draw Slide SPR567-7020K
Lid Stay SPR567-6950K
Draw Liner SPR567-6610K

For Prices see Page 605



Colour	Width (mm)	Depth (mm)	Height (mm)	Weight each	Order Code
Red	670	320	390	26kg	SEN-594 -0240K

3 Tray Tool Trolley

Bolted steel construction. 100mm industrial castors. Brakes fitted to two end castors. Hard wearing powder coated finish.



Overall Length	Overall Width	Overall Depth	Weight each	Order Code
737mm	383mm	663mm	3.70kg	SEN-594 -4030K

HAND TOOLS



ROLLER CABINETS & TOOL CHESTS



Roller Cabinets

Double thickness side walls with welded joints and a hard wearing epoxy powder coating. I-Beam draw slides with double sliders on base drawer. 100mm rubber castors with brakes fitted to two end castors. Fully locking. Castors are rated to 40kg capacity standing load per castor. Drawer loads should be evenly distributed. Roller cabinets are not suitable for frequent relocation when loaded and should only ever be pushed.

Spares	Order Code
Lock	SPR-567-7210K
Key Blank	SPR-567-7320K
Draw Slide	SPR-567-7050K
Castors	SPR-567-6900K
Top Mat	SPR-567-7560K
Draw Liner	SPR-567-6610K

For Prices see Below

3 Drawer

Overall dimensions (W x D x H):
680 x 435 x 660mm.

Drawer sizes (W x D x H):
3@ 511 x 403 x 75mm.

Bottom compartment (W x D x H):

678 x 425 x 368mm.
Uses 16" drawer slides.



Colour	Weight each	Order Code SEN-594
Red	26kg	-1030K

5 Drawer

Overall dimensions (W x D x H):
680 x 435 x 660mm.

Drawer sizes (W x D x H):
3@ 511 x 403 x 75mm.

2@ 551 x 403 x 155mm.
Uses 16" drawer slides.



Colour	Weight each	Order Code SEN-594
Red	33kg	-1050K

7 Drawer

Overall dimensions (W x D x H): 670 x 460 x 885mm.

Drawer sizes (W x D x H):
4@ 590 x 410 x 50mm.

2@ 590 x 410 x 100mm.

1@ 590 x 410 x 200mm.
Uses 16" drawer slides.



Colour	Weight each	Order Code SEN-594
Red	51kg	-0580K

Cabinet & Chest Spares

* Note: Draw liner size is 583 x 405mm and can be cut to size. All spare keys are supplied as blanks and will need cutting to size.

Cabinet/Chest Order Code	Order Code SPR-567	Order Code SPR-567	Order Code SPR-567	Order Code SPR-567	Order Code SPR-567	Order Code SPR-567	Order Code SPR-567
KENNEDY							
KEN-594-1540K	-7210K	-7320K	-7040K	-	-	-	-6610K
KEN-594-2020K	-	-	-	-	-	-	-
KEN-594-2040K	-	-	-	-	-	-	-
KEN-594-2120K	-	-	-	-	-	-	-
KEN-594-2140K	-	-	-	-	-	-	-
KEN-594-2220K	-	-	-	-	-	-	-
KEN-594-2240K	-	-	-	-	-	-	-
KEN-594-2320K	-	-	-	-	-	-	-
KEN-594-2340K	-	-	-	-	-	-	-
KEN-594-2420K	-	-	-	-	-	-	-
KEN-594-2620K	-	-	-	-	-	-	-
KEN-594-4820K	-7240K	-7320K	-7060K	-4820K	-	-	-6610K
KEN-594-4840K	-7210K	-7320K	-7040K	-	-6910K	-	-6610K
KEN-594-4860K	-7240K	-7320K	-7060K	-4860K	-	-	-6610K
KEN-594-4880K	-7210K	-7320K	-7040K	-	-6910K	-	-6610K
KEN-594-5200K	-7240K	-7320K	-7000K	-6950K	-	-	-6610K
KEN-594-5210K	-7240K	-7320K	-7000K	-6950K	-	-	-6610K
KEN-594-5240K	-7240K	-7320K	-7000K	-6950K	-	-	-6610K
KEN-594-5250K	-7240K	-7320K	-7000K	-6950K	-	-	-6610K
KEN-594-5280K	-7240K	-7320K	-7040K	-6950K	-	-	-6610K
KEN-594-5290K	-7240K	-7320K	-7040K	-6950K	-	-	-6610K
KEN-594-5340K	-7240K	-7320K	-7060K	-6960K	-	-	-6610K
KEN-594-5360K	-7240K	-7320K	-7060K	-6960K	-	-	-6610K
KEN-594-5400K	-7210K	-7320K	-7040K	-	-	-7560K	-6610K
KEN-594-5410K	-7210K	-7320K	-7040K	-	-	-7560K	-6610K
KEN-594-5500K	-7260K	-7320K	-7040K	-	-6920K	-7560K	-6610K
KEN-594-5510K	-7260K	-7320K	-7040K	-	-6920K	-7560K	-6610K
KEN-594-5540K	-7210K	-7320K	-7040K	-	-6920K	-7560K	-6610K
KEN-594-5550K	-7210K	-7320K	-7040K	-	-6920K	-7560K	-6610K
KEN-594-5580K	-7210K	-7320K	-7040K	-	-6920K	-7560K	-6610K
KEN-594-5590K	-7210K	-7320K	-7040K	-	-6920K	-7560K	-6610K
KEN-594-5700K	-7260K	-7320K	-7040K	-	-6920K	-7520K	-6610K
KEN-594-5740K	-7210K	-7320K	-7040K	-	-6920K	-7540K	-6610K
KEN-594-5780K	-7240K	-7320K	-7040K	-6970K	-	-6780K	-6610K
KEN-594-6020K	-7210K	-7320K	-7040K	-	-6910K	-7540K	-6610K
SENATOR							
SEN-594-0200K	-7200K	-7300K	-7020K	-	-	-	-6610K
SEN-594-0240K	-7240K	-7320K	-7020K	-6950K	-	-	-6610K
SEN-594-0580K	-7210K	-7320K	-7050K	-	-6900K	-7560K	-6610K
SEN-594-1030K	-7210K	-7320K	-7050K	-	-6900K	-7560K	-6610K
SEN-594-1050K	-7210K	-7320K	-7050K	-	-6900K	-7560K	-6610K
SEN-594-1530K	-	-	-	-	-	-	-
SEN-594-1550K	-	-	-	-	-	-	-
SEN-594-1570K	-	-	-	-	-	-	-
SEN-594-1660K	-	-	-	-	-	-	-
YAMOTO							
YMT-594-0200K	-7240K	-7320K	-7020K	-6950K	-	-	-6610K
YMT-594-0240K	-7240K	-7320K	-7020K	-6950K	-	-	-6610K
YMT-594-0280K	-7240K	-7320K	-7020K	-6950K	-	-	-6610K
YMT-594-0500K	-7210K	-7320K	-7050K	-	-6900K	-7560K	-6610K
YMT-594-0540K	-7210K	-7320K	-7050K	-	-6900K	-7560K	-6610K
YMT-594-0580K	-7210K	-7320K	-7050K	-	-6900K	-7560K	-6610K
YMT-594-1500K	-	-	-	-	-	-	-
YMT-594-1520K	-	-	-	-	-	-	-
YMT-594-1600K	-	-	-	-	-	-	-
YMT-594-1620K	-	-	-	-	-	-	-
YMT-594-1640K	-	-	-	-	-	-	-
YMT-594-5240K	-7180K	-7340K	-7080K	-6980K	-	-	-6610K
YMT-594-5580K	-7180K	-7340K	-7100K	-	-6930K	-7560K	-6610K

PRODUCTS ARE ONLY AVAILABLE VIA YOUR DISTRIBUTOR



Tool Control



CAD designed and high precision laser cut foam tray inserts are designed to keep tools precisely and accurately in the correct position and drawers for improved productivity. In some applications a dropped tool is a serious hazard and colour contrasting foam inserts are used to easily recognise lost tooling and also reduce audit time. Areas of use include food industry maintenance, automotive assembly.



25 Piece Set

Professional Pliers

- 1x 160mm snipe nose.
- 1x 160mm diagonal cutters.
- 1x 160mm combination.

Pro-Torq Screwdrivers

Crosspoint:

- No.2 x stubby, No.2 x 100mm.

Pozidriv:

- No.1 x 75,
- No.2 x 100,
- No.3 x 150mm.

Flared:

- 6.3 x 150, 8.0 x 200mm.

Parallel:

- 5.0 x 150mm.

Metric Professional Combination Wrenches

- 6, 7, 8, 9, 10, 11, 12, 13, 14, 15, 16, 17, 18 and 19mm.

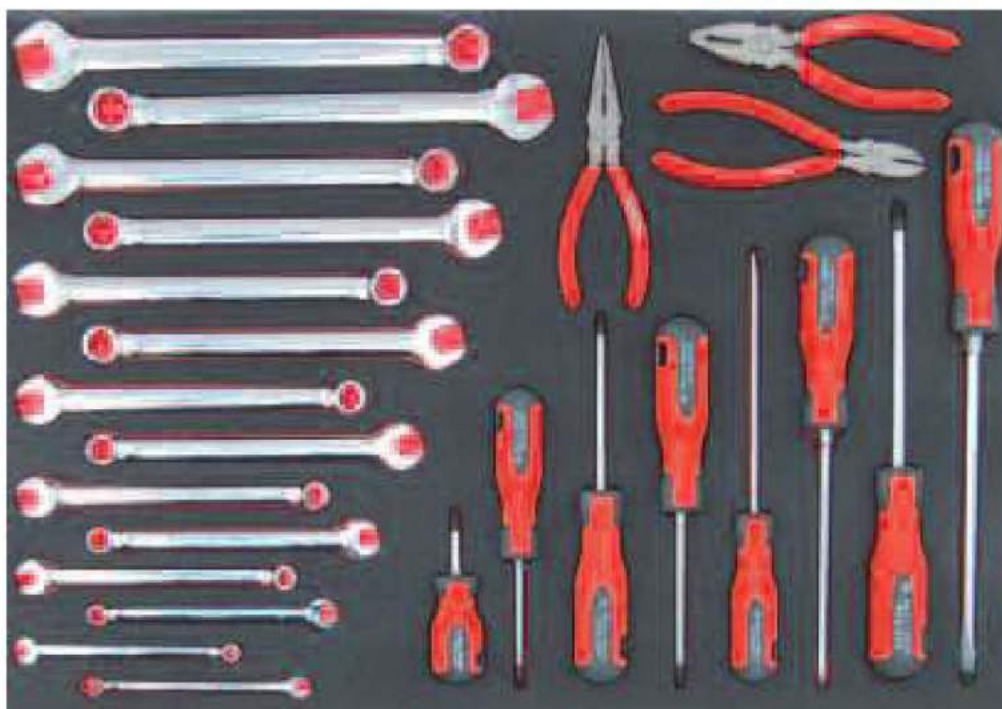

**25
PIECES**

Product Number	Weight each	Order Code
TCD025	2.3kg	KEN-595 -5000K

Dimensions: 590 x 410 x 25mm

Suitable for Kennedy Toolchests - **KEN- 594-5580K & KEN- 594-5590K**
(see page 597 for details)

50 Piece Set

- 3/8" Sockets:** 6, 7, 8, 9, 10, 11, 12, 13, 14, 15, 16, 17, 18, 19, 20, 21 and 22mm.

Deep Sockets:

- 10, 11, 12, 13, 14, 15, 17, 19 and 22mm.

Screwdriver Bits:

Slotted

- 5, 5.5 and 6.5mm.

Crosspoint

- No.1, 2, 3, and 4.

Hex Bits:

- 3, 4, 5, 6, 8 and 10mm.

Accessories:

- Ratchet handle, sliding T-handle, spinner handle, swivel handle. Universal joint.
- 125 and 250mm extensions,
- 250mm wobble extensions,
- 1/4" and 1/2" male adaptors,
- 1/4" hex bit coupler.



**50
PIECES**

Product Number	Weight each	Order Code
TCD050	6.2kg	KEN-595 -5020K



KENNEDY PROFESSIONAL Complete Tool Control Sets include Kennedy Professional Roller Cabinet

Manufactured from heavy gauge steel with double wall construction side panels and welded joints for added rigidity. Coated in a hard wearing epoxy powder. Fully opening drawers for extra accessibility. Quick release smooth running ball bearing drawer slides with double sliders on base drawer. Supplied with top mat and drawer liners. Fully locking. 125 x 50mm heavy duty extra strong castors, fitted with two brakes.

Overall dimensions: 890 x 690 x 460mm. Castors are rated to 100kg capacity standing load per castor. Drawer loads should be evenly distributed.
Drawers (W x D x H): 4@ 590 x 410 x 50mm. 2@ 590 x 410 x 100mm. 1@ 590 x 410 x 200mm.

7 Drawer Roller Cabinet

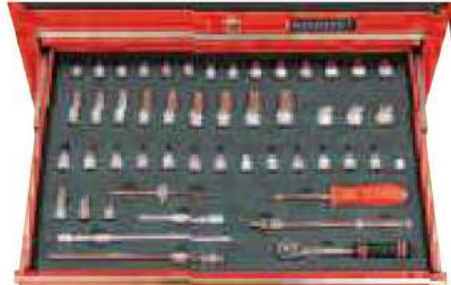
25 Piece Set Configuration

50 Piece Set Configuration

25 Piece Set with Professional Roller Cabinet
Professional Pliers

1x 160mm snipe nose,
 1x 160mm diagonal cutters,
 1x 160mm combination.

Metric Professional Combination Wrenches

6, 7, 8, 9, 10, 11, 12, 13,
 14, 15, 16, 17, 18 and 19mm.

Pro-Torq Screwdrivers

Crosspoint: No.2 x stubby,
 No.2 x 100mm.

Pozidriv(r): No.1 x 75, No.2 x 100,
 No.3 x 150mm.

Flared: 6.3 x 150,
 8.0 x 200mm.

Parallel: 5.0 x 150mm.

**25
PIECES**
50 Piece Set with Professional Roller Cabinet

Sockets: 6, 7, 8, 9, 10, 11,
 12, 13, 14, 15, 16, 17,
 18, 19, 20, 21 and 22mm.

Deep Sockets: 10, 11, 12, 13,
 14, 15, 17, 19 and 22mm.

Screwdriver Bits

Slotted: 5, 5.5 and 6.5mm.

Crosspoint: No.1, 2, 3, and 4.

Hex Bits: 3, 4, 5, 6, 8 and 10mm.

Accessories:

Ratchet handle, sliding
 T-handle, spinner handle, swivel
 handle. Universal joint. 125 and
 250mm extensions, 250mm
 wobble extensions, 1/4" and 1/2"
 male adaptors, 1/4" hex bit
 coupler.

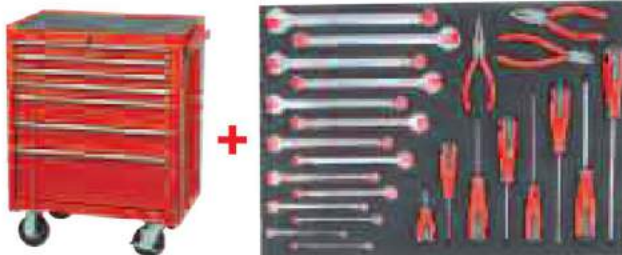
**50
PIECES**
HAND TOOLS

 Product
 Number

TCC025

 Weight
 each

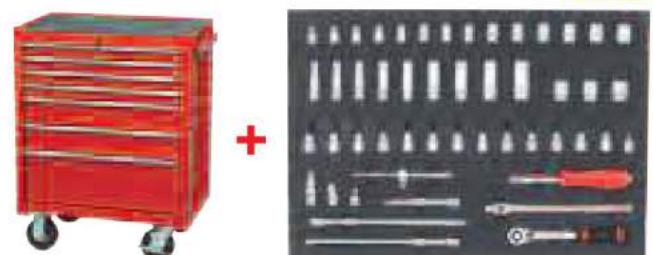
55.3kg

 Order Code
KEN-595
-5540K

 Product
 Number

TCC050

 Weight
 each

59.2kg

 Order Code
KEN-595
-5520K
75 Piece Set With Professional Roller Cabinet
Professional Pliers

1x 160mm snipe nose,
 1x 160mm diagonal cutters,
 1x 160mm combination.

Pro-Torq Screwdrivers

Crosspoint: No.2 x stubby, No.2 x 100mm.

Pozidriv(r): No.1 x 75, No.2 x 100,
 No.3 x 150mm.

Flared: 6.3 x 150, 8.0 x 200mm.

Parallel: 5.0 x 150mm.

Sockets: 6, 7, 8, 9, 10, 11, 12, 13, 14,
 15, 16, 17, 18, 19, 20, 21 and 22mm.

Deep Sockets: 10, 11, 12, 13, 14,
 15, 17, 19 and 22mm.

Screwdriver Bits

Slotted: 5, 5.5 and 6.5mm.

Crosspoint: No.1, 2, 3, and 4.

Hex Bits: 3, 4, 5, 6, 8 and 10mm.

Accessories:

Ratchet handle, sliding
 T-handle, spinner handle, swivel
 handle. Universal joint.

125 and 250mm extensions,
 250mm wobble extensions,
 1/4" and 1/2" male adaptors,
 1/4" hex bit coupler.

**75
PIECES**

 Product
 Number

TCC075

 Weight
 each

61.5kg

 Order Code
KEN-595
-5500K
PRODUCTS ARE ONLY AVAILABLE VIA YOUR DISTRIBUTOR

GROUP
595

TOOL KITS

KENNEDY
PROFESSIONAL

208 Piece Apprentice Engineer's Tool Kit - AET200

208
PIECES



Supplied in a three drawer professional roller cabinet and a three drawer top chest. Manufactured from heavy gauge steel with double wall construction side panels and welded joints for added rigidity. Coated in a hard wearing epoxy powder. Fully opening drawers for extra accessibility. Quick release smooth running ball bearing drawer slides with double sliders on base drawer. Supplied with top mat and drawer liners. Fully locking. 125 x 50mm heavy duty extra strong castors, fitted with two brakes. Overall dimensions: 890 x 690 x 460mm. Castors are rated to 100kg capacity standing load per castor. Drawer loads should be evenly distributed.

3 Drawer Top Chest

Top compartment size: 89 x 661 x 150mm.

Drawer sizes: 1@ 51 x 591 x 282.5mm.

2@ 102 x 591 x 282.5mm.

3 Drawer Roller Cabinet

Internal drawer dimensions

Bottom compartment size: 610 x 432 x 356mm.

Drawer sizes: 3@ 591 x 410 x 102mm.

Contents:

- 25 piece HSS drill set 1 - 13.00mm x 0.5mm.
- Six piece 200mm double cut engineer's file set.
- Six piece 16cm cut 2 assorted needle file set.
- 25 x 230 x 280mm assorted abrasive sheet.
- 200mm chrome vanadium steel adjustable spanner.
- 6 x 150mm flat cold chisel.
- 19mm x 33m black pvc insulation tape.
- 76mm, 18 blade combination feeler gauge set.
- 4.8mm square head centre punch.
- 150mm/6" stainless steel rule c/w pocket clip.
- 178mm double ended Engineers' scriber.
- Eye loupe.
- Adjustable telescopic 30mm dia. inspection mirror (expands to 180mm).
- Six piece parallel pin punch set: 2.4, 3.2, 4.0, 4.8, 5.5 and 6.4mm.
- 150mm/6" engineer's square - **BS 939 grade B**.
- Tap wrenches 1.5 - 6.4mm and 6.4 - 19mm.
- Magnetic telescopic pick-up tool extends to 550mm.
- 29 piece engineer's bit set. All 6mm hex x 25mm overall length, complete with magnetic spinner handle, 6mm hexagon bit adaptor and 6mm square socket adaptor. Hexagon: 2, 3, 4, 5, 6, 7 and 8mm; flat 3, 4, 5, 5.5, 6.5 and 8mm; $\frac{3}{32}$ ", $\frac{1}{8}$ ", $\frac{5}{32}$ ", $\frac{3}{16}$ ", $\frac{1}{4}$ ", $\frac{7}{32}$ " and $\frac{9}{16}$ "; crosspoint No.1, 2 and 3; Pozidriv® No.1, 2 and 3.
- 450g (1lb) ball pein hammer wood shaft.
- 7.5m/25ft steel tape.
- Snap-off eight segment blade economy knife.
- Retractable trimming knife with five blades.
- Junior hacksaw frame.
- 300mm lightweight professional hacksaw frame.
- Six off 12" x $\frac{1}{2}$ " x 18tpi HSS hacksaw blades.
- 20 junior hacksaw blades.
- Two plastic handle household scissors.
- 150mm snipe nose plier with side cutter.
- 150mm diagonal cutting nipper.
- 150mm Engineers' combination pliers with side cutter.
- 250mm curved jaw high strength grip wrench.
- Eight piece Pro-Torq screwdriver set: crosspoint No.1 x 75, No.2 x 100; pozidriv® No.2 x 100; flared 6.3 stubby, 6.3 x 100, 8.0 x 200; parallel 5.0 x 75, 5.0 x 150.
- 14 piece combination spanner set: 6, 7, 8, 9, 10, 11, 12, 13, 14, 15, 16, 17, 18 and 19mm.
- 25 piece metric socket set $\frac{1}{2}$ " square drive sockets: 8, 9, 10, 11, 12, 13, 14, 15, 16, 17, 18, 19, 22, 24, 27, 30 and 32mm. Spark plug sockets: M10 and M14. Accessories: quick release ratchet handle, sliding T-handle, universal joint, 75, 125 and 250mm extension bars.
- Nine piece metric hex key set 1.5 - 10mm.



Set contents may vary slightly according to product development and availability.

HAND TOOLS

Order Code
KEN-595
-0550K

608

PRODUCTS ARE ONLY AVAILABLE VIA YOUR DISTRIBUTOR

© 2018



KENNEDY PROFESSIONAL 300 Piece Engineer's Professional Tool Kit

Supplied in a five drawer professional roller cabinet and a three drawer top chest. Manufactured from heavy gauge steel with double wall construction side panels and welded joints for added rigidity. Coated in a hard wearing epoxy powder. Fully opening drawers for extra accessibility. Quick release smooth running ball bearing drawer slides with double sliders on base drawer. Supplied with top mat and drawer liners. Fully locking. 125 x 50mm heavy duty extra strong castors, fitted with two brakes.

Overall dimensions: 890 x 690 x 460mm.
Castors are rated to 100kg capacity standing load per castor. Drawer loads should be evenly distributed.

3 Drawer Top Chest

Top compartment size: 89 x 661 x 150mm.

Drawer sizes: 1@ 51 x 591 x 282.5mm,
2@ 102 x 591 x 282.5mm.

5 Drawer Roller Cabinet

Internal drawer dimensions:

4@ 591 x 460 x 102mm.

1@ 591 x 410 x 204mm.

Contents:

- Set of 25 HSS drills 1 - 13.00mm x 0.5mm.
- Eight piece 200mm (8") double cut Engineers' file set.
- Six piece 16cm cut 2 assorted needle file set
- 20x 150mm (6") junior hacksaw blades.
- 10x 12" x 1/2" x 18TPI HSS all hard hacksaw blade.
- 25x 230mm x 280mm assorted abrasive sheets.
- 200mm (8") soft grip phosphate adjustable wrench.
- 6mm 150mm flat cold chisel.
- 3" 18bade metric/inch comb feeler gauge set.
- 4" x 3/16" (4.8mm) square head centre punch.
- Set of 6 parallel pin punches.
- 150mm/6" inch/metric rigid rustless rule.
- 300mm/12" rigid rustless rule - round end.
- 150mm (6") Engineer's square.
- 300mm (12") Engineer's square.
- 7" double ended engineers scribe.
- 1 1/4" focal length eye loupe.
- Adjustable telescopic 1 1/4" mirror.
- Set of two: 1/16" - 1/4" and 1/4" - 3/4" tap wrenches.
- 1lb ball pein hammer - wood shaft.
- 16oz black rubber mallet - wood shaft.
- 5 1/2" plastic handle household scissors.
- 8 1/2" plastic handle household scissors.
- 5m/16" professional ABS steel tape.
- Snap-off 8 seg-blade heavy duty knife.
- Snap-off 13 seg-blade mini knife.
- Retractable trimming knife c/w five blades.
- Beaver style junior hacksaw.
- Professional 'plus' cushion grip hacksaw.
- Magnetic pick-up tool.
- Set of four Pro-Torq pliers.
- 10" curved jaw grip wrench
- 12 piece Pro-Torq screwdriver set.
- 64 piece 1/4" hexagon bit set.
- 1/4" hex bit driver.
- Seven piece box spanner set 6 - 19mm c/w tommy bars.
- Combination wrenches: 10 - 19mm.
- 50 piece metric 3/8" square drive socket set.
- 8" straight blade tinsnip.
- Three drawer professional tool chest.
- Metal tote tray
- Five drawer professional roller cabinet.
- Eight piece metric Pro-Torq hex wrench set on clip.
- Nine piece inch Pro-Torq hex wrench set on clip.
- 19mm x 33m black PVC insulation tape.

Order Code
KEN-595

-3080K

TOOL KITS

**GROUP
595**



**300
PIECES**



HAND TOOLS

Set contents may vary slightly according to product development and availability.

PRODUCTS ARE ONLY AVAILABLE VIA YOUR DISTRIBUTOR

609

GROUP
595

TOOL KITS

YAMOTO 100 Piece Mechanic's Starter Tool Kit

Contents:

- 8" and 12" satin chrome adjustable wrench set.
- 5m/16ft locking tape rule.
- Lightweight hacksaw frame.
- 400cc lever type steel grease gun.
- 150mm long nose pliers.
- 200mm long nose pliers.
- 150mm diagonal nippers.
- 150mm linesman's combination pliers.
- 200mm linesman's combination pliers.
- 250mm waterproof pliers.
- 12 piece mechanic's pattern screwdriver set.
- Seven piece 6 - 19mm chrome vanadium open ended spanner set.
- 14 piece 6 - 19mm chrome vanadium combination spanner set.
- 55 piece 3/8" drive socket and bit set.
- Six drawer red tool chest.

**100
PIECES**



Weight each
34.0kg

Order Code
YMT-595
-3500K

52 Piece Mechanic's Tool Kit

Specifically designed for mechanics on the move.

Contents include: 582 x 298 x 255mm metal toolbox with tote tray, adjustable wrenches, pocket knife, pliers, screwdrivers, spanners and sockets.

**52
PIECES**



Set contents may vary slightly according to product development and availability.

Order Code
YMT-595
-2600K

HAND TOOLS

SENATOR 90 Piece Engineer's Workshop Tool Kit

Contents:

- Top chest.
- 24 piece 1/2" drive metric socket set.
- Six piece 16cm cut 2 assorted needle file set.
- 10x 12" x 1/2"x 18tpi all hard hacksaw blades.
- 8"/200mm chrome vanadium adjustable spanner.
- 12" rule - walled.
- Metric/inch feeler gauge 60mm blade length.
- 1 1/2lb ball pein hammer- hickory shaft.
- 16oz black rubber mallet - wood shaft.
- 5m/16ft locking tape rule - chromed case.
- Eight segment 18mm heavy duty snap-off blade knife.
- Retractable trimming knife.
- DIY hacksaw.
- 2x 50mm G-clamps.
- 2x 100mm G-clamps.
- 6" snipe nose plier/side cutter.
- 8" straight blade tinsnip.
- 6" diagonal cutting nipper.
- 7" linesman's pliers.
- 10" multiple slip joint pliers.
- 10" straight jaw high strength grip wrench.
- 16 function 10-blade tool.
- 15 piece duel grip screwdriver set.
- 14 piece 6 - 19mm drop forged. combination spanner set.

**90
PIECES**



Set contents may vary slightly according to product development and availability.

Order Code
SEN-595
-1000K

610

PRODUCTS ARE ONLY AVAILABLE VIA YOUR DISTRIBUTOR

© 2018

KENNEDY PROFESSIONAL 62 Piece Workshop Tool Kit

Five compartment cantilever tool box with specially moulded trays to facilitate enhanced Tool Control and padlock hole for additional security.

Contents:

- Sockets: 8 - 32mm, M10 and M14 spark plug
- 250mm sliding T-handle
- 125mm and 250mm extensions, 75mm wobble extension
- Quick release 72T rubber hatchet handle
- 375mm/15" jointed knurl gripped swivel handle
- Universal joint
- Combination spanners: 6 -22mm.
- Pro-Torq screwdrivers: 5.5 x 100mm, 6.5 x 150mm and 8 x 200mm flat, No.0, No.2 and No.3 cross point
- Pro-Torq pliers: 180mm/7" combination, 150mm/6" snipe nose and 165mm/6" diagonal
- Metric L-wrench ball driver set - 1.5 - 10mm

**62
PIECES**

Order Code
KEN-595
-0050K

Specially Moulded Trays
KENNEDY QUALITY INDUSTRIAL TOOLING 107 Piece Apprentice Engineer's Tool Kit

Contents:

- Toolbox
- 6 piece Pro-Torq screwdriver set: crosspoint No.1 x 75 and No.2 x 100mm; flared 6.3 x 100 and 8.0 x 250mm; parallel 5 x 100 and 5 x 200mm
- 6 piece screwdriver set: crosspoint PH0 and PH1; parallel 1.4, 2.0, 2.4, and 3.0mm
- 6 - 19mm 14 piece metric combination spanner set.
- 9 piece metric hex key set: 1.5 - 10mm
- 8 piece 2nd cut file set: one each flat, hand, round, half round, 3 square and square
- 12 piece 2nd cut needle file set: 1 each hand, flat, knife, round, half round, square, 3 square, crossing, round edge joint, slitting, warding and barrette
- 2 of each grade 0, 1 and 2 emery sheets
- 200mm/8" adjustable wrench
- 18 blade metric/inch feeler gauge
- Magnetic pick-up tool extends to 650mm
- 7.5m/25ft locking tape rule
- Snap-off blade knife
- Junior hacksaw
- 20 junior hacksaw blades
- 300mm (12") hacksaw frame
- 6 hacksaw blades
- Shears
- 3 piece professional plier set
- 255mm straight jaw grip wrench
- 6 x 150mm flat cold chisel
- 1lb ball pein hammer
- 175mm engineer's scriber
- 30mm diameter inspection mirror (extends to 650mm)
- Centre punch
- 150mm (6") engineer's square
- 150mm (6") pocket rule
- 100cc grease gun
- Eye loupe

**107
PIECES**

Set contents may vary slightly according to product development and availability.

Model Number	Weight each	Order Code
AET100	4.2kg	KEN-595 -0500K

SENATOR QUALITY TOOLING 162 Piece Power Bit Set

Containing the most commonly used screwdriver bits, nut spinners, Torx bits, drills and adaptors. Supplied in a moulded carry case.

Dimensions (W x D x H): 455 x 178 x 297mm.

Contents includes:

- 32x 25mm (1") driver bits consisting of: slotted, crosspoint, square, pozi and torx.
- 24x 50mm (2") screwdriver bits consisting of: slotted, crosspoint and torx.
- 5x300mm (12") extra length masonry drills plus 11x standard length masonry drills.
- 18x nut driver bits.
- 1x screw finder.
- 9x flat wood bits.
- 17x woodworking drills.
- 5x holesaw with mandrel.
- 1x ruler. 1x centre punch.
- 1x ratcheting bit driver.
- 4x drill bit depth stop.
- 1x countersink.
- 1x carpenter's pencil.

**162
PIECES**

Weight each
3.4kg

Order Code
SEN-595
-3180K

PRODUCTS ARE ONLY AVAILABLE VIA YOUR DISTRIBUTOR

**KENNEDY
PROFESSIONAL**
**49 Piece Computer
Technician's Tool Kit**

The kit is supplied in a Kennedy® professional tool and lap top bag.

Contents:

- Hexagon wrench set 1.5 to 6mm.
- Precision nut driver set 3.0 to 5.0mm.
- Flat blade precision tweezers 170mm.
- Sharp nose precision tweezers 115mm.
- 3-in-1 multimeter.
- Micro diagonal nipper 110mm.
- Automatic wire stripper 0.2 to 6mm capacity.
- Insulated VDE screwdriver set: parallel: 2.5 x 85mm, 4.0 x 100mm, 5.5 x 125mm, 6.5 x 150mm; crosspoint: No.0 x 75mm, No.1 x 100mm, No.2 x 100mm.
- Crimping tool, capacity 8P8C/RJ-45, 6P/RJ-12, RJ-11 and 6P2C.
- Cable ties, black, 2.5 x 160mm packet of 100.
- Precision screwdriver set (in zip case): parallel 1.4 x 40mm, 2.0 x 40mm, 2.4 x 75mm, 3.0 x 75mm and 4.0 x 100mm blade length; crosspoint PH0-3 x 40mm, PH0-2 x 75mm, PH-0 x 75mm and PH1 x 100mm blade length.
- ESD long nose pliers 130mm.
- ESD bent nose pliers 140mm.
- ESD flat nose pliers 130mm.
- Edison™ aluminium torch.
- Black PVC insulation tape 19mm x 33m.
- Air duster 400ml.
- Absorbent wipes (pack of 50).
- Screen wipes (2x pack of 20).
- 1x pair Polyco® pure dex anti-static gloves.
- Non-contact AC voltage detector.
- Retractable blade knife.
- Brushes: No.6 and No.10 flat fitch.

**49
PIECES**

Order Code
KEN-595
-3200K



Set contents may vary slightly according to product development and availability.

122 Piece 'Deluxe' Service Engineer's Tool Kit

This superb kit contains all the necessary tools for the service engineer in a sturdy aluminium case partitioned to keep tools organised and readily accessible.

Contents:

- Aluminium tool case.
- Six piece 16cm needle file set.
- 150mm adjustable wrench.
- Digital multimeter.
- 125/250V mains tester.
- 19mm x 33m insulation tape: black, red and green/yellow PVC.
- 25W soldering iron.
- Cable stripping knife.
- Desoldering gun.
- 60/40 cored solder.
- Butane soldering torch.
- Centre punch 2.4 x 3.2mm.
- 2x parallel pin punches.
- 150mm/6" flexible rustless rule.
- Machinists scribe.
- Sharp nose tweezers.
- Flat blade tweezers.
- Eye loupe.
- Telescopic inspection mirror.
- Magnetic pick up tool (extends to 550mm).
- 225g (½lb) ball pein hammer.
- 3½ oz cross pein hammer.
- 7.5m/25ft steel tape.
- Aluminium pocket torch.
- Retractable knife.
- Auto return utility knife.
- Junior hacksaw and blade.
- 10 junior hacksaw blades.
- 150mm flat nose plier.
- 150mm insulation and wire stripping plier.
- 150mm wire crimper/stripper.
- 160mm snipe nose plier.
- 160mm diagonal cutting nipper.
- 160mm combination plier.
- 4 piece circlip plier set.
- 177mm locking pliers.
- 115mm precision flat nose pliers.
- 115mm precision long nose pliers.
- 115mm precision nippers.
- 115mm precision end cutting pliers.
- 165mm soft touch pliers.
- Pro-Torq grip screwdrivers with chrome vanadium blade: slotted 100 x 6mm; crosspoint 76mm x No.0 and No.1, 6mm x No.2; supadriv 76mm x No.0 and 1, 4" x No.2; electrician's parallel 150 and 200 x 5mm.
- Offset screwdrivers: 5mm x No.1, 6mm x No.2.
- Insulated screwdrivers: parallel 4 x 100mm, 1000V VDU, slotted 5.5 x 125mm.
- Torx screwdrivers: T6, T8 and T10.
- 11 piece screwdriver and tool set.
- Nine piece 5.5 - 13mm combination spanner set.
- Seven piece electronic screwdriver set.
- Six piece 0 - 11 BA open ended spanner set.
- Multi-purpose snips.
- Seven piece metric hexagon key set.
- Multi-purpose oil.
- 20mm sash tool.
- 100 cable ties.
- Scissors.

**122
PIECES**

Weight
each
14.0kg

Order Code
KEN-595
-3040K

Set contents may vary slightly according to product development and availability.



KENNEDY PROFESSIONAL 102 Piece Service Engineer's Tool Kit

Contents

- Hi-impact mobile tool case.
- Six piece 16cm cut 2 needle file set.
- 150mm chrome finish adjustable wrench.
- 150mm mains tester range 125/250V.
- 19mm x 33m insulation tape: black, red and green/yellow pvc.
- Soldering iron 25W 240V.
- Desoldering gun.
- Cable stripping knife.
- 17g 1.0mm diameter 60/40 cored solder.
- Square head centre punch 3.2 x 100mm.
- 150mm/6" flexible rustless rule.
- Precision tweezers: 115mm sharp nose, 120mm flat blade. • Eye loupe.
- 30mm dia. telescopic inspection mirror (handle expands to 480mm).
- 225g (1/2lb) ball pein hammer.
- 7.5m/25' steel tape.
- 13 segment blade mini autolock retractable knife.
- Junior hacksaw frame c/w hardened blade.
- 10 junior hacksaw blades for metal.
- 215mm plastic handle scissors.
- Magnetic pick up tool.
- 160mm snipe nose pliers.
- 160mm diagonal cutting nippers.
- 160mm combination pliers with side cutter.
- 150mm insulation and wire stripping pliers.
- 115mm precision flat nose pliers.
- 115mm precision long nose pliers.
- 115mm precision nippers.
- 115mm precision end cutting nippers.
- Pro-Torq grip screwdrivers with chrome vanadium blade: slotted 100 x 6mm; crosspoint 76mm x No.0 and No.1, 6mm x No.2; supadriv 76mm x No.0 and No.1, 100mm x No.2; electricians': parallel 150 and 200 x 5mm.
- Offset screwdrivers: 5mm x No.1 and 6mm x No. 2.
- 1000V VDU insulated screwdrivers: parallel 4 x 100mm; slotted 5.5 x 125mm.
- Torx screwdrivers: T6, T8 and T10.
- 11 piece screwdriver and tool set: parallel 1, 1.2, 1.4, 1.8, 2.4 and 3mm; crosspoint PHO-2, PHO and PH1, fine point awl and tweezers.
- Seven piece electronic screwdriver set: parallel 1.4, 2, 2.4 and 3mm; crosspoint PHO-3, PHO-2 and PHO.
- Six piece chrome vanadium steel 0 - 11 BA open ended spanner set.
- 20mm diameter sash tool.
- Nine piece hex key set 1.5 - 10mm.
- Chrome vanadium combination spanners: 5.5, 6, 7, 8, 9 and 10mm.

Set contents may vary slightly according to product development and availability.



Weight each
13.0kg

Order Code
KEN-595
-3020K

56 Piece Standard Service Tool Kit

Suitable for use by service engineers, electricians and tradesmen. All Kennedy industrial quality tools carry a quality guarantee.

Contents:

- 430 x 340 x 160mm ABS plastic, aluminium reinforced, tool case.
- 150mm chrome adjustable wrench.
- 19mm x 33m black PVC insulation tape.
- 150mm mains tester range 125/250V.
- Soldering iron 25W/240V.
- Desoldering gun.
- 17g 1.0mm diameter 60/40 cored solder.
- 115mm sharp nose precision tweezers.
- 30mm diameter inspection mirror (handle extends up to 480mm).
- 7.5m/25ft steel tape.
- 13 segment-blade mini autolock retract knife.
- Junior hacksaw frame and blade.
- Magnetic pick up tool (extends to 550mm).
- 160mm snipe nose pliers.
- 160mm diagonal cutting nippers.
- 160mm engineer's combination pliers with side cutter.
- 150mm insulation and wire stripping pliers.
- 115mm precision nippers.
- 115mm precision end cutting nippers.
- Chrome vanadium blade screwdrivers: crosspoint No.0, 1 and 2pt; slotted 6mm; supadriv No.0, 1 and 2pt.
- Offset screwdrivers: 5mm slot x No.1pt, 6mm slot x No.2pt.
- Insulated screwdrivers: parallel 4 x 100mm 1000V VDU, slotted 2.5 x 85mm.
- 20mm sash tool.
- 11 piece screwdriver and tool set: parallel 1, 1.2, 1.4, 1.8, 2.4 and 3mm; crosspoint PHO-2, PHO and PH1; fine point awl and tweezers.
- 9 piece hex key set 1.5 - 10mm.
- Chrome vanadium combination spanners: 5.5, 6, 7, 8, 9 and 10mm.

Set contents may vary slightly according to product development and availability.



Weight each
6.8kg

Order Code
KEN-595
-3000K

56
PIECES

PRODUCTS ARE ONLY AVAILABLE VIA YOUR DISTRIBUTOR

KENNEDY PROFESSIONAL 16 Piece Electrician's VDE Tool Bag & Kit

Heavy duty tear-resistant tool bag with Hook-n-Loop fastening flap. Double webbed shoulder strap fixed with metal release clasps. Two removable tool boards inside which have a unique tool storage securing system built in. All tools are VDE approved.

Contents:

- Electrician's tool bag (320 x 340 x 125mm).
- 150mm euro tester will detect 'live' electricity supply. Suitable for AC to 125 - 250V, 3mm wide tip. Conform to **VDE 0630 Part 4**.
- 145mm (5¾") Pro-Torq grip diagonal nippers, 1000V insulated.
- 160mm (6¾") Pro-Torq snipe nose pliers, 1000V insulated.
- 165mm (6½") Pro-Torq engineer's combination pliers, 1000V insulated.
- 170mm (6¾") Pro-Torq wire strippers, 1000V insulated.
- 7 piece VDE dual grip screwdriver set: No.0 x 60, No.1 x 80 and No.2 x 100mm, 2.5 x 75, 4.0 x 100, 5.5 x 125 and 6.5 x 150mm.
- 180mm (7") insulated cable knife, curved blade.
- 2x small parts storage boxes.



**16
PIECES**

Width (mm)	Depth (mm)	Height (mm)	Order Code
320	125	340	KEN-595 -3400K

17 Piece 'Live Line' VDE Tool Kit

Contents:

- Tear-resistant tool roll (600 x 300mm).
- 190mm euro tester - will detect 'live' electricity supply. Suitable for AC to 125 - 250V. 3mm wide tip. Conform to **VDE 0630 Part 4**.
- 145mm (6¼") Pro-Torq grip diagonal nippers, 1000V insulated.
- 160mm (6¾") wire strippers.
- Engineer's combination pliers and snipe nose pliers, 1000V insulated.
- 240mm (9½") water pump box joint pliers, 1000V insulated.
- 200mm adjustable wrench 1000V insulated.
- 7 piece insulated VDE screwdriver set: parallel: 2.5 x 85, 4.0 x 100, 5.5 x 125 and 6.5 x 150mm; crosspoint: No.0 x 75, No.1 x 100 and No.2 x 200mm.
- 180mm (7") insulated cable knife curved blade.
- 210mm (8¼") cable cutter.



Both rolls have a riveted carry handle on the outside.



**17
PIECES**

Width (mm)	Depth (mm)	Height (mm)	Order Code
320	125	340	KEN-595 -3420K

10 Piece 1000V Dual Grip Screwdriver & Plier Set



Fully insulated professional high grip dual material handles that are VDE tested up to 1000V. Screwdrivers have magnetic tips, chrome vanadium steel blades and a hanging hole. Pliers have chrome vanadium steel double polished head and joint heads.

Contents:

Screwdrivers:

- Crosspoint:**
- No.0 x 60mm,
 - No.1 x 80mm,
 - No.2 x 100mm.

Parallel:

- 2.5 x 75mm,
- 4.0 x 100mm,
- 5.5 x 125mm,
- 6.5 x 150mm.

Pliers:

- 6¾" Pro-Torq snipe nose pliers,
- 6¼" Pro-Torq grip nipper pliers,
- 6½" Pro-Torq engineering combination pliers.



**10
PIECES**

Weight each
1.4kg

Order Code
KEN-595
-1600K



KENNEDY QUALITY INDUSTRIAL TOOLING 7 Piece Maintenance Tool Kit



MTK7

Contents:

- Chrome adjustable wrench.
- Slotted electrician's VDE screwdriver.
- Slip joint pliers.
- High tensile diagonal cutting nippers.
- Universal combination pliers.
- No.2 crosspoint engineer's screwdriver.
- Flared slotted engineer's screwdriver.
- PVC tool roll.

**7
PIECES**

Weight each
1.3kg

Order Code
KEN-595
-0070K



SENATOR QUALITY TOOLING 33 Piece Home Handyman Kit
HHK32

Supplied in a robust Tuff-E toolbox with a tote tray for carrying tools to the job and a multi-compartment storage box with lid.

Contents:

- 18 piece wood, metal and masonry drill set, 6x wood drills 3, 4, 5, 6, 8 and 10mm; 6x masonry drills 3, 4, 5, 6, 8 and 10mm; 6x HSS drills 3, 4, 5, 6, 8 and 10mm.
- 8 piece fluted handle screwdriver set: flared: 6mm stubby, 3 x 100mm and 8 x 200mm; parallel: 3.2 x 75mm and 4 x 150mm; pozidriv: No.2 stubby, No.1 x 75mm and No.2 x 100mm.
- Diagonal cutting nippers 150mm/6".
- Snipe nose pliers with side cutter 150mm/6".
- Linesman's pliers 180mm/7".
- 8 segment snap-off blade knife with a contour moulded grip.
- 3m/10ft locking tape rule in a tough plastic case.

Set contents may vary slightly according to product development and availability.

**33
PIECES**

 Weight each
6.41kg

 Order Code
SEN-595
-0500K

51 Piece Home Handyman Tool Kit
HHK51

Supplied in a robust Tuff-E double latched toolbox.

Contents:

- 8 piece fluted handle screwdriver set: flared 6mm stubby, 3 x 100mm and 8 x 200mm; parallel 3.2 x 75mm and 4 x 150mm; pozidriv No.2 stubby, No.1 x 75mm and No.2 x 100mm.
- 10 piece screwdriver bit set: 6mm quick release hex bit adaptor; flat 3, 4, 5, 6 and 8mm; crosspoint No.0, 1, 2 and 3mm.
- 200mm (8") chrome vanadium adjustable spanner.
- 225mm (9") hi-vis magnetic boat level. • 600mm (24") hi-vis girder section level. • 150mm mains tester, range 125/250V.
- 19mm x 33m black PVC insulation tape. • Adjustable telescopic 300mm dia inspection mirror. • 450g (16oz) claw hammer wood shaft. • 3m/10ft hi-vis locking tape. • 13 seg 9mm standard snap-off blade knife. • Retractable trimming knife c/w 5 blades.
- 150mm (6") junior hacksaw blade for metal (10).
- 300mm (12") DIY hacksaw frame.
- 177mm (7") plastic handle household scissors.
- 63mm (2½") half tang filling knife. • 76mm (3") half tang scraper.
- Magnetic pick-up tool extends to 650mm.
- 150mm (6") linesman's pliers.
- 125mm (5") snipe nose pliers.
- 125mm (5") diagonal cutting nippers.
- 255mm (10") straight jaw grip wrench.
- Bradawl.
- 600 piece wall plug set.

Set contents may vary slightly according to product development and availability.

**51
PIECES**

 Weight each
7.0kg

 Order Code
SEN-595
-0520K

61 Piece Home Handyman Tool Kit
HHK61

Supplied in a robust double latched toolbox.

Contents:

- Tool box with tote and wheels.
- 8 piece fluted handle screwdriver set: flared 6mm stubby, 3 x 100mm and 8 x 200mm; parallel 3.2 x 75mm and 4 x 150mm; pozidriv No.2 Stubby, No.1 x 75mm and No.2 x 100mm.
- 10 piece screwdriver bit set: 6mm quick release hex bit adaptor; flat 3, 4, 5, 6, and 8mm; crosspoint No.0, 1, 2 and 3mm.
- 18 piece wood, metal and masonry drill set 3, 4, 5, 6, 8 and 10mm bits.
- IDH013 240V 13mm impact drill.
- 200mm (8") chrome vanadium adjustable spanner.
- 225mm (9") hi-vis magnetic boat level.
- 600mm (24") hi-vis girder section level.
- 19mm x 33m black PVC insulation tape.
- 150mm euro tester range 125/250V.
- Adjustable telescopic 300mm diameter inspection mirror.
- Magnetic pick-up tool extends to 650mm.
- Bradawl.
- 450g (16oz) claw hammer wood shaft.
- 3m/10ft Senator hi-vis locking tape.
- 13 segment 9mm standard snap-off blade knife.
- Retractable trimming knife c/w 5 blades.
- Junior hacksaw frame c/w hardened blade.
- DIY hacksaw frame.
- 177mm (7") plastic handled multi-purpose household scissors.
- 63mm (2½") half tang filling knife.
- 76mm (3") half tang scraper.
- 150mm (6") linesman's pliers.
- 125mm (5") snipe nose pliers.
- 125mm (5") diagonal cutting nippers.
- 255mm (10") straight jaw grip wrench.
- 22" x 8pts homesaw hand saw.

Set contents may vary slightly according to product development and availability.

**61
PIECES**

 Weight each
16kg

 Order Code
SEN-595
-0540K

PRODUCTS ARE ONLY AVAILABLE VIA YOUR DISTRIBUTOR

615

© 2018

GROUP 595 TOOL KITS

SENATOR QUALITY TOOLING 23 Piece Builder's Construction Tool Kit



- 9" (225mm) hi-vis magnetic boat level.
- 24" (600mm) hi-vis girder section level.
- 6" London pattern pointing trowel.
- 11" board heel brick trowel.
- 11½" x 4½" plasterer's finishing trowel.
- 1½" ball pein hammer with hickory shaft.
- 16oz claw hammer with wooden shaft.
- 3m/10ft hi-vis locking tape with yellow casing.
- 30m/100ft fibre glass measuring tape.
- 13 segment 9mm standard snap-off blade knife.
- Retractable trimming knife.
- 6" diagonal cutting nippers.
- 8" linesman's pliers.
- Eight piece fluted handle screwdriver set.
- 10" straight blade tinsnips.
- 24" canvas tool bag.

**23
PIECES**

Set contents may vary slightly according to product development and availability.

new



Weight each **Order Code**
4.2kg **SEN-595**
-1500K

22 Piece Plumber's Kit

Supplied in a robust toolbox c/w double latch.

Contents:

- Tool box. • 255mm (10") stillson wrench.
- 3 - 22mm capacity tubing cutter.
- 3 - 41mm tube deburrer.
- 9.5 - 32mm basin wrench.
- 300mm girder section spirit level.
- Telescopic inspection mirror.
- Junior hacksaw frame c/w hardened blade.
- Pad saw.
- 255mm groove slip joint waterpump plier.
- 6 piece flat wood bit set 9.5 - 25mm.
- 12mm x 12m PTFE thread sealing tape to **BS6920**.
- 100g fluxite paste.
- Powerflow lead free solder 3.25mm 250g.
- 3 row plastic handle wire scratch brush.
- 450g grade 2 wire wool.
- Blow lamp and 2175 gas cartridge.

**22
PIECES**



Order Code
KEN-595
-4010K

HAND TOOLS

47 Piece Engineer's Workshop Tool Kit

- Six piece 16cm cut 2 assorted needle file set. • 10x 12 x ½" x 18T all hard hacksaw blades.
- 8" (200mm) C/V adjustable spanner. • 6" (150mm) stainless steel rule with pocket clip.
- Metric and inch feeler gauge, blade length: 60mm.
- 1lb ball pein hammer with hickory shaft.
- 16oz black rubber mallet with wooden shaft.
- 5m/16ft locking tape rule with chrome casing.
- 8 segment 18mm heavy duty snap-off blade knife.
- Retractable trimming knife.
- 12" DIY hacksaw.
- 6" heavy duty snipe nose pliers with side cutter.
- 6" diagonal cutting nippers.
- 7" linesman's pliers.
- 10" multiple slip joint pliers.
- 10" straight blade tinsnips.
- 10" straight jaw high strength grip wrench.
- 8 piece fluted handle screwdriver set.
- 7 piece 6 - 19mm drop forged open-ended spanner set.
- 21" five tray cantilever toolbox.



**47
PIECES**



Weight each **Order Code**
6.4kg **SEN-595**
-0700K

Set contents may vary slightly according to product development and availability.

KENNEDY PROFESSIONAL 29 Piece Pro-Torq Maintenance Tool Bag & Kit
Contents:

- Electrician's tool bag (320 x 340 x 125mm).
- 2x small bits organiser cases.
- One tool board unique system to secure tools whilst in transit.
- 140mm (5½") autoloader and lock knife - 13 segment snap-off blade.
- 165mm (6½") Pro-Torq diagonal nippers.
- Pro-Torq diagonal nippers.
- 150mm (6") Pro-Torq snipe nose pliers with side cutter.
- 150mm (6") Pro-Torq combination pliers.
- Six piece Pro-Torq screwdriver set: crosspoint No.1 x 75, No.2 x 100; flared 6.3 x 100, 8.0 x 200; parallel 5.0 x 75, 5.0 x 150mm.
- Seven piece Pro-Torq precision screwdriver set: parallel tips 1.4, 2.0, 2.4 and 3.0mm; crosspoint tips PH0-3, PH0-2 and PH-0.
- 200mm (8") soft grip phosphate adjustable wrench.
- Eight piece Pro-Torq hex wrench set on clip 1.5 - 8.0mm.

**29
PIECES**

Width (mm)	Depth (mm)	Height (mm)	Order Code
320	125	340	KEN-595 -3440K

25 Piece Decorator's Preparation Kit
Contents:

- 5x dust masks.
- 5x sheets grade 0 glass paper and grade 2 glass paper.
- 50mm half tang scraper.
- 75mm half tang scraper.
- 38mm chisel point half tang putty knife.
- 200mm half tang combination shavehook.
- Window scraper.
- Sanding block - fine and medium.
- 310ml cartridge of decorator's acrylic caulk.
- 310ml cartridge gun - plastic.
- 460mm canvas tool bag.

**25
PIECES**
new

 Order Code
KEN-595
-4100K
45 Piece Pro-Torq Maintenance Tool Roll Kit
Contents:

- Tear-resistant tool roll (600 x 300mm).
- 140mm auto-load and lock knife - 13 segment snap-off blade.
- Telescopic magnetic pick-up tool extends to 550mm (22").
- 150mm (6") Pro-Torq snipe nose pliers with side cutter.
- 165mm (6") Pro-Torq diagonal nippers.
- Six piece Pro-Torq screwdriver set: crosspoint No.1 x 75, No.2 x 100; flared 6.3 x 100, 8.0 x 200; parallel 5.0 x 75, 5.0 x 150mm.
- 14 piece chrome vanadium combination spanner set 6 - 19mm.
- Three piece offset screwdriver set: No.1 crosspoint x 3/16" parallel, No.2 crosspoint x 3/4" parallel and No.3 crosspoint x 5/16" parallel.
- Seven piece Pro-Torq precision screwdriver set: parallel tips 1.4, 2.0, 2.4 and 3.0mm; crosspoint tips PH0-3, PH0-2 PH-0.
- 200mm (8") soft grip phosphate adjustable wrench.
- Eight piece Pro-Torq hex wrench set on clip 1.5 - 8.0mm.

**45
PIECES**

Roll has a riveted carry handle on the outside.



Width (mm)	Height (mm)	Order Code
330	600	KEN-595 -3460K

KENNEDY QUALITY INDUSTRIAL TOOLING 18 Piece Decorator's Painting Kit
Contents:

- 2x 25mm industrial paint brush.
- 13, 50, 75 and 100mm industrial paint brushes.
- 240mm economy paint tray - plastic.
- 230mm wide birdcage (jumbo) paint roller.
- 230mm long pile polyester roller refill.
- 230mm medium pile polyester roller refill.
- 230mm wide foam paint roller refill.
- Long pile radiator roller complete.
- Long pile radiator roller refill.
- Metal telescopic handle.
- General purpose masking tape 19mm x 50m and 50mm x 50m.
- 460mm canvas tool bag.
- Dust sheet.

**18
PIECES**
new

 Order Code
KEN-595
-4140K
PRODUCTS ARE ONLY AVAILABLE VIA YOUR DISTRIBUTOR

617

GROUP 595 CYCLE TOOLS

SENATOR CYCLONE Cycle Work Stand

CWS152

Quick to set up, this fold-away cycle work stand has telescopic height adjustment, and plastic jaw clamps to securely grip the frame or seat post.

Specifications:

Construction: light alloy and tough ABS Plastic, rubber feet.

Dimensions: closed: 23 x 22 x 102cm,
open: 70 x 100 x 164cm.

Jaw opening: min: 25mm diameter, max: 75mm diameter.

Weight: 5.3kg.



Cycle not included



Product Number
CWS152

Order Code
SEN-595
-4480K

15 Piece Cycle Repair Kit

This comprehensive kit is ideal for cycle repairs at home, comes in its own wallet and measures 90 x 200 x 40mm. Large than the multi-tools but still small enough to carry in a ruck sack or pannier for those touring holidays.

Contents:

- 2x 'Y' box wrenches: 8, 9, 10mm and 12, 13 and 14mm.
- 150mm (6") adjustable wrench 20mm max. opening.
- Hook spanner with 15 and 16mm open ended cone wrench.
- Screwdriver handle: crosspoint No.1 and No.2.
- Slotted bits: 4 and 6mm.
- 3x hex key wrenches: 4, 5, 6 and 8mm hex adaptor.
- 1x forged steel 'O' spoke adjuster: 10, 11, 12, 13, 14 and 15 G.E. 3x tyre levers.

15
PIECES



Order Code
SEN-595
-4460K



These specialist products are made from quality materials to give high levels of performance and durability. Whether you are doing emergency roadside repairs or general maintenance, the **SENATOR CYCLONE** range is all that you would expect from a top supplier of industrial tools.

Cycle Multi-Tools

CMT091 - One of the smallest multi tools on the market. Comfortable in the hand, or in the pocket. It has chrome vanadium steel blades and a matt coated frame.

Includes:

- Hex keys, 2, 2.5, 3, 4, 5 and 6mm.
- Torx key T25.
- No.1 crosspoint bit.
- 5mm slotted bit.

9-in-1



Product Number
CMT091

Order Code
SEN-595
-4420K

CMT161 - Another very compact multi tool from **SENATOR CYCLONE** range with 16 useful chrome vanadium blades and chain rivet extractor.

Includes:

- Hex keys: 2, 2.5, 3, 4, 5 and 6mm.
- Adaptor for 8mm hex key.
- 1x 10mm spanner.
- 1.2mm and No.1 crosspoint bits.
- 1.2mm and 5mm slotted bits.
- 1x tyre lever.
- 2x spoke wrenches: 14 and 15 G.E.
- 1x chain rivet extractor.

16-in-1



Product Number
CMT161

Order Code
SEN-595
-4400K

HAND TOOLS

KENNEDY PROFESSIONAL Tool Tethers, Lanyards & Accessories
Any Tool, Tether IT!

Dropped tools are a major cause of workplace injury and fatalities – most of which could be avoided with the correct tethering and use of tools. Safe use of tools at height begins with the tool tether, which acts as a secure attachment point for lanyards and ultimately tool belts and harnesses. Utilising a patented system developed by Tool@rest, a pioneering name in the field of tethered tools, Kennedy can Retr@fit almost all new and existing hand tools with a certified, statistically fail-safe tether. This means you can enjoy industry leading tether safety without buying new tools and Retr@fitting can be carried out on your site or in a factory setting in a matter of seconds. And it doesn't stop there. Kennedy can now offer a complete solution to help prevent tools from falling, including securing of the tools-in-waiting (tools in the work belt or holster) and those in active use.

Lifting Buckets

Rugged, tested and large enough for multiple tools and applications. With eight internal carabiners stitched in to secure tools-in-waiting. 250mm diameter.

Safe working load: 34kg.

CE Certified with serial number for LOLER traceability.

TBB-34C

Standard bucket with open top.

TBB-34T

Toggle drawstring type - recommended for use in situations where untethered fasteners or sockets are being worked with. Closing the drawstring ensures that these loose items are prevented from falling in the event of a bucket tip or drop.



Product Number	Type	Order Code KEN-596
TBB-34C	Open Top	-1442B
TBB-34T	Toggle Closing	-1445E

Retr@ct 360 Retracting Lanyard

High-impact resistant polyamide casing. Self cleaning re-wind brake and release mechanism. 360° rotational capability. Patent pending. SP30 cord tensile strength 260kg.

Length: 1.2m (fully extended).

TLR-135

Standard lanyard with snap hook carabiner and single harness buckle.

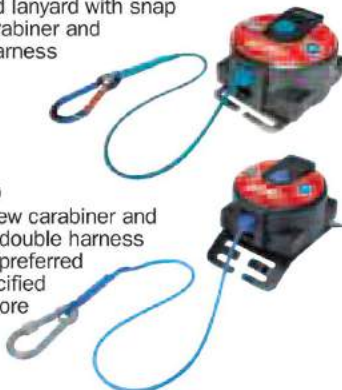
TLR-130

With screw carabiner and non-slip double harness buckle - preferred and specified by off-shore users

Product Number	Max. Working Capacity	Order Code KEN-596
TLR-135	2.5kg	-3020K
TLR-130	2.5kg	-3010K

Wrist Lanyards

Supplied complete with wrist wraps and swivel tail. Toggle style tails are also available - see below.



Product Number	Max. Working Capacity	Order Code KEN-596
TWS-20C	2kg	-1574D

Lanyard Tails

Wrist lanyard tails for use with Kennedy wrist wraps.



Product Number	Max. Working Capacity	Order Code KEN-596
TTW-20S	2kg	-1544D
TTW-20T	2kg	-1546F

Power Tool WR@P

For use with Li-Ion and Ni-Cad 18V power tools only. High strength nylon webbing. Innovative, patent-pending design.



Product Number	Max. Working Capacity	Order Code KEN-596
TPW-18L	2.5kg	-1506F

Quick Change Belt Loops

Snap-fit tool belt anchor point for securing tool lanyards.



Product Number	Max. Working Capacity	Order Code KEN-596
TBL-25Q	2.5kg	-1452B

Quick Change Tool Lanyard

Stretchable cord surrounded by tubular polyester webbing. Available with a range of tails for easy application on different tools.



Product Number	Max. Working Capacity	Order Code KEN-596
TLE-1QC	2.5kg	-1482B

Quick Change Tool Lanyard Tails

For use with Kennedy quick change tool lanyard only.



Product Number	Max. Working Capacity	Order Code KEN-596
TTQ-25C	2.5kg	-1524D
TTQ-25T	2.5kg	-1526F

Webbing Lanyards

100cm webbing lanyard. Durable polyester webbing construction. Complete with two stainless steel carabiners.



Product Number	Max. Working Capacity	Order Code KEN-596
TLW-1C2	2.5kg	-1486F

HAND TOOLS
PRODUCTS ARE ONLY AVAILABLE VIA YOUR DISTRIBUTOR



KENNEDY Masonry Saws

Hardened and tempered steel blades with carbide teeth. Light Concrete Saw. Suitable for cutting cement based building blocks. 17 tungsten carbide tips on alternate teeth.



Blade Duty	Blade Length	Teeth per inch	Weight each	Order Code
Heavy	700mm	2	890g	KEN-597 -5720K

SITESAFE

Hardpoint Compass Saw

Flexible spring blade. Set and sharpened teeth. High impact moulded plastic handle. For cutting apertures and curves in a wide range of materials.



Can also be used as a pruning saw.

Blade Length	Teeth per inch	Order Code
300mm (12")	8	SSF-597 -5340K

KENNEDY Pad Saw

Heavy-duty foam grip for maximum comfort. Accepts 1/2" deep hacksaw blades. Suitable for use in areas of awkward access.



Overall Length	Weight each	Order Code
210mm (8 1/4")	130g	KEN-538 -1000K

Pad Saw

For use in confined spaces.



Blade Length	Weight each	Order Code
230mm (9")	140g	KEN-597 -5270K
Spare Blade		KEN-597 -5280K

Plasterboard Saw

Suitable for rapidly cutting holes in plasterboard. Hardened and tempered carbon steel blade with polished rosewood handle and brass ferrule. 7TPI.



Blade Length	Weight each	Order Code
150mm (6")	105g	KEN-597 -5660K

KENNEDY Coping Saw

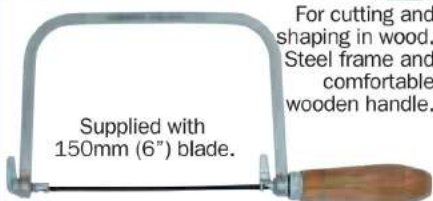

For cutting and shaping in wood. Steel frame and comfortable wooden handle.

Supplied with 150mm (6") blade.

Overall Length	Weight each	Order Code
290mm	200g	KEN-538 -2100K

Spare Coping Saw Blades (to suit above):

Teeth per inch	Pack Quantity	Order Code
14	10	KEN-040 -1020K

Steel Back Gent's Saws

Suitable for precise flush cutting. Sprung alloy steel blade with rigid steel back, polished rosewood handle and brass ferrule.

Blade width: 60mm (2 1/4").



Blade Length	Weight each	Order Code
150mm (6")	180g	KEN-597 -5460K
200mm (8")	200g	KEN-597 -5480K

Brass Back Dovetail Saw

Alloy steel blade, tensioned with hardened and ground teeth. Heavy rigid brass back and polished rosewood handle. Securely fastened with two brass screws. 20TPI.



Blade Length	Weight Per 10	Order Code
200mm (8")	500g	KEN-597 -5420K

Professional Tenon Saw

Manufactured from hardened and ground steel with glazed and polished blade, tensioned and fully sprung. Highly polished brass back and handle. Supplied in wallet with tooth guard. **15 points per inch.**



Blade Length	Weight Per 10	Order Code
250mm (10")	6.0kg	KEN-597 -4600K

KENNEDY Beechwood Sawing Blocks

Mitre box and block pre-cut at 45° and 90°. **Mitre Box**



Internal Size (mm)	Order Code
230 x 76	KEN-597 -6090K

Mitre Block

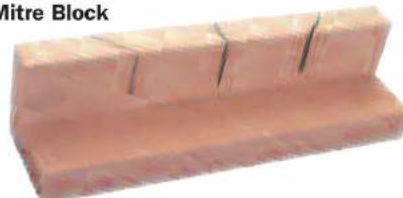

Internal Size (mm)	Order Code
230 x 76	KEN-597 -6190K

Bench Hook

Manufactured from the quality beech wood. Hooks into the edge of the bench allowing the workpiece to be held firmly against one end whilst cutting or marking out. Universal - left and right handed.



Internal Size (mm)	Order Code
230 x 150	KEN-597 -6290K

SITESAFE

Hardpoint Veneer Saw

Curved end allows cutting up to skirts and corners. Set and sharpened teeth. High impact moulded plastic handle. Hardened and tempered spring steel blade. 14TPI. **15 points per inch.**



Blade Length	Teeth per inch	Order Code
330mm (13")	14	SSF-597 -5620K

KENNEDY Corner Clamp

Ideal for use with wood, angle and tubing. Clamping jaws swivel to accept various widths. Die cast aluminium body with bench mounting.

Base :
158 x 158mm.
Jaw depth: 36mm.
Slot width: 10mm.



Maximum Clamping	Weight each	Order Code
70 x 70mm	1.40kg	KEN-597 -6000K

HAND TOOLS

KENNEDY Folding Saw Horse - Twin Pack

The Kennedy Saw Horse is designed for supporting wooden planks and boards and is recommended for use in pairs. It has spreader bars for extra stability and features a support bar on the top with metric and inch scale and end stops to secure the workpiece in place. Folds flat for easy transportation and storage.

- Non-slip rubber inserts, prevent work piece slipping
- Folds flat for easy transportation and storage
- Suitable for on site and workshop use
- Rated to 100kg per pair
- Metric and inch scale on the top
- Waterproof

Spreader Bars
Securing End Stops

Dimensions (open) L x W x H (cm)	Dimensions (closed) L x W x H (cm)	Max Load per pair	Order Code KEN-597
52 x 61 x 79.5	5.5 x 61 x 82.5	100kg	-8140K



KENNEDY PROFESSIONAL Meteor Hand Saw

High quality hardened and tempered steel blade with specially hardened teeth.

8 points per inch (7tpi)



Blade Length	Teeth Per Inch	Order Code KEN-597
550mm (22")	7	-4900K
550mm (22")	11	-4920K

Reversible Gent's Saw

Suitable for flush cutting in the most awkward corners on the left or right hand side. Reversible offset alloy steel blade cranked and polished with rigid back. Rosewood handle with brass ferrule. 15TPI.



Blade Length	Weight each	Order Code KEN-597
250mm (10")	305g	-5400K

SITESAFE Hardpoint Hand Saw

Hardened and tempered blade. Designed to cut chipboard, blockboard, timber, plywood, hardboard, plasterboard and laminates. Specially hardened teeth to stay sharp longer. Tough handle with fingerline for comfort and accuracy. 8TPI.



Blade Length	Teeth per inch	Order Code SSF-597
560mm (22")	8	-4780K

Mini Gent's Saws

Suitable for light duty precise cutting. Narrow blade width allows use in confined areas. Polished rosewood handle with brass ferrule.

Blade width: 40mm (1½").



Blade Length	Weight each	Order Code KEN-597
150mm (6")	160g	-5560K

KENNEDY PROFESSIONAL Flexi Flush Cutting Saw

Suitable for precise cutting in confined areas or around obstructions. Flexible alloy steel blade, which cuts on the pull stroke. Polished rosewood handle with brass ferrule. 20TPI.



Blade Length	Weight each	Order Code KEN-597
155mm (6")	120g	-5520K

KENNEDY PROFESSIONAL Professional Hand Saw

Hardened and ground steel with glazed and polished blade, tensioned and fully sprung. Supplied in wallet with tooth guard.



Blade Length	Teeth per inch	Order Code KEN-597
560mm (22")	9	-4700K

KENNEDY PROFESSIONAL Hardpoint Tenon Saw

Has file sharpened teeth with plain hardened cutting edges. Impact resistant handle. High quality.

13 points per inch.



Blade Length	Weight Per 10	Order Code KEN-597
250mm (10")	3.8kg	-4620K

PRODUCTS ARE ONLY AVAILABLE VIA YOUR DISTRIBUTOR

© 2018

Using Your Plane

- Always hold the plane firmly to ensure optimum balance and control. Ensure the workpiece is secure and stand behind the plane - never pull a plane towards your body.
- When planing end-grain, plywood, blockboard or difficult/curlly grain, the direction of the cut is extremely important. A 'slice' action is advised or splitting may occur. This is achieved by holding the plane at an angle as shown.
- Splitting can generally be prevented in several ways:
 - 1) By planing towards the centre of the workpiece
 - 2) Bevel the corner of the workpiece before planing
 - 3) Clamp scrap wood level with the edge of the surface being planed and plane it straight across.



Maintaining Your Plane

- A plane is a precision tool, therefore it should always be treated with care. Always store the plane on its side - this will avoid unnecessary damage to the blade.
- Always sharpen the blade before use. This will make it easier, and safer to use and produce a superior surface finish.
- Before sharpening the blade take the blade out of the plane and remove the cap iron. Always lay the blade cap iron flat on a firm surface before taking out the screw.
- Sharpen your blade using an oilstone. Best results are achieved by using a honing guide - this will give the ideal angle at the cutting edge of the blade.
- Use machine oil to keep the surface of the stone wet but remove excess before use. This is to prevent dust and metal particles from clogging the stone.
- Remove any burrs by laying the front of the blade flat on the oilstone and work it in a "figure-eight" motion.
- Painted surfaces should be sanded or stripped back before planing in order to avoid clogging of the blade and damage to the timber.
- Never plane over nails, this will damage the blade.
- Always wipe the blade with a cloth before replacing it.
- Candle wax applied to the sole of the plane may reduce friction, especially on freshly cut timber.

HAND TOOLS

SENATOR QUALITY TOOLING **Block Plane**

No. 200

Suitable for any single handed operation in particular for end-grain work. The low angle plane cutter ensures minimal vibration giving an excellent finish on many man made materials such as plastic laminates. Adjustable 40mm width steel cutting blade with ground base and sides for smooth planing. Large screw for accurate adjustments.



Cast iron body with adjustable cutter depth and alignment.

Model Number	Length (mm)	Iron Width	Weight each	Order Code
200	178	41mm	0.80kg	SEN-597 -0990K

Smoothing Plane

No. 4

Used for general purpose smoothing and final finishing. Featuring a robust level cap designed to lock down on three points for secure location of the cutting iron. High performance carbon steel blade, hardened and tempered to retain a keen cutting edge to cut even the hardest of woods. Impact resistant ABS resin handle and knob are extremely robust and contoured to fit comfortably in the hand, for maximum control and reduced user fatigue. Suitable for single and two handed operations. Traditional adjusting nut for fine setting.



Model Number	Length (mm)	Iron Width	Weight each	Order Code
4	247	51mm	1.93kg	SEN-597 -0940K

Jack Plane

No. 5

Fully adjustable metal plane for stock removal and truing up long edges or levelling wide boards. Kidney shaped lever cap screw hole prevents accidental slippage of cutter. High performance carbon steel blade, hardened and tempered to retain a keen cutting edge. Fully adjustable frog for all tasks and timber types. Virtually unbreakable polypropylene handle and knob shaped for comfort. Finger tip adjustment for depth of cut and cutter alignment. Tight fitting spring steel cap iron for optimum shaving flow. Cast fine grey iron base for stability and wear resistance. Precision ground base and sides ensure performance to the highest tolerances.



Model Number	Length (mm)	Iron Width	Weight each	Order Code
5	355	51mm	3.2kg	SEN-597 -0920K

With tough enamelled alloy bodies and high carbon heat treated steel blades.

Flat File - Straight Handle

For straight filing with flat blade as standard. Plastic handle.

Block Plane

For single handed use, giving compactness and precision filing.

Plane

For conventional plane type filing. With flat blade as standard. Black plastic handle.

Shaver Tool

With plastic holder.

Round File - Straight

For convex and concave surface shaping. Wooden handle.



Tool Style	Blade Length	Blade Width	Overall Length	Weight each	Order Code KEN-597
Flat File	255mm	40mm	395mm	400g	-1010K
Plane	255mm	40mm	285mm	400g	-1070K
Block Plane	140mm	40mm	140mm	130g	-1110K
Shaver Tool	63mm	40mm	185mm	60g	-1150K
Round File	255mm	16mm	360mm	125g	-1240K

Replacement Blades

To Suit	Blade Type	Weight each	Order Code KEN-597
Flat File or Plane	Flat	40g	-2020K
Block Plane	Half-Round	40g	-2040K
Shaver Tool	Flat	30g	-2060K
Round File	Curved	10g	-2080K
	Round	40g	-2100K

Sanding Sheets

Industrial aluminium oxide sanding paper is 'glue' bonded and suitable for use with hand sanding blocks and orbital sanders.



Grit	Weight per 25	Order Code KEN-200
1/3 Sheet (93mm Wide x 230mm Long)		
P80 Med	290g	-9150K
P50 Cse	330g	-9190K
1/2 Sheet (115mm Wide x 280mm Long)		
P120 Fine	400g	-9410K
P80 Med	380g	-9450K
P50 Cse	570g	-9490K

1/4 Sheet Hand Sanding Pad

Made from compound rubber. With curved and flat sides. Complete with locating spikes.



Suitable for all types of coated abrasive sheets. Accepts a standard 230 x 280mm sheet split down into quarters across the width, as shown.

Width x Length x Height (mm)	Weight each	Order Code KEN-280
70 x 125 x 35	360g	-4100K

Cabinet Scraper Set

For fine surface finishing of intricate contour surfaces. Used to manually remove small amounts of material and excels in tricky grain areas where hand planes would cause tear out. They will stand up to any heavy-duty scraping task with minimum tear out. For best results, these scrapers should be burnished to a razor sharp edge.

**3
PIECES**

Weight Set	Order Code KEN-597
170g	-7400K



**Bevel Edge
Wood Chisels**

Craftsman

Hammer-blow resistant handles. For craftsmen and joiners. Designed to give a life-time of high performance. Chrome vanadium alloy blades, hardened, tempered, ground and polished. 'CAB' (Cellulose Acetate Butyrate handles).



Blade mm	Width Inch	Weight per 12	Order Code KEN-597
6	1/4"	1.90kg	-2800K
10	3/8"	2.20kg	-2820K
13	1/2"	2.35kg	-2840K
16	5/8"	2.50kg	-2860K
19	3/4"	2.60kg	-2880K
25	1"	3.00kg	-2900K
38	1 1/2"	3.85kg	-2940K



Set No. of Pieces	Contents	Weight each	Order Code KEN-597
4	6, 13, 19, & 25mm	880g	-2980K

Professional

'Classic' pattern. For professional carpenters.



Blade mm	Width Inch	Weight per 12	Order Code KEN-597
6	1/4"	1.90kg	-2160K
10	3/8"	2.10kg	-2240K
13	1/2"	2.20kg	-2320K
16	5/8"	2.40kg	-2400K
19	3/4"	2.50kg	-2480K
25	1"	2.80kg	-2640K
38	1 1/2"	3.70kg	-2680K



Set No. of Pieces	Contents	Weight each	Order Code KEN-597
4	6, 13, 19, & 25mm	800g	-2970K



**Carpenter's
Chisel Set**

Made from quality materials and complete with its own canvas storage wallet. Bevel edged chrome vanadium blades, hardened, tempered, ground and polished. Comfortable bi-material handles with impact resistant end caps.

Contents: 6mm (1/4"), 13mm (1/2"), 19mm (3/4") and 25mm (1") chisels.

**4
PIECES**



Order Code
SEN-597
-2970K



**Turning
Tool Set**

Contents: three straight gouges, two skew chisels, one V-parting tool, one round nose and one diamond point. HSS steel blades. All supplied in a wooden presentation case.

Blade length: 125mm.
Handle length: 250mm.

**8
PIECES**



Weight each
2.25kg

Order Code
SEN-597
-3940K

Wood Carving Tool Set

Contents: four straight gouges, two square chisels, two skew chisels, two V-parting tools, one veiner and one spoon bit. Alloy steel blades. All supplied in a quality wooden presentation case.

Blade length: 110mm.
Handle length: 95mm.

**12
PIECES**



Weight each
1.30kg

Order Code
SEN-597
-3960K

KENNEDY Hand Drill

Double pinion drill with die cast body and three jaw keyless chuck. Plastic handle with plastic grips and screw top, for bit storage. Used for small drilling operations.



Double Pinion



Group 279

Overall Length	Weight per 6
215mm	2.80kg



Extra Grip

8mm Chuck

Order Code
KEN-597
-0600K

WOODWORKING TOOLS

GROUP 597

Heavy Duty Breast Drill

Heavy duty two speed breast drill with a heavy cast construction and enclosed gearing. Fitted with a three jaw keyless 13mm chuck and supplied with two removable wooden handles. The plate is pressed against the chest to force the drill point into the work.



Folds flat for storage

13mm Chuck

Overall Length	Weight each	Order Code
330mm	1.10kg	KEN-597
		-0640K

Beechwood Mallet

Traditional carpenter's pattern.



Head Size	Weight each	Order Code
114mm (4 1/2")	520g	KEN-597
		-6450K

Marketry Punch

Beechwood handle, for piercing holes in veneer and thin wood.



Length x Diameter	Weight each	Order Code
65 x 3mm	25g	KEN-597
		-7250K

Adjustable Hole Cutter

For use on metal, wood, plastics, laminates and leather etc.

Cutting diameter can be infinitely varied within range. Graduated scale with locking screw. For use in three jaw chucks (6.4mm shank).

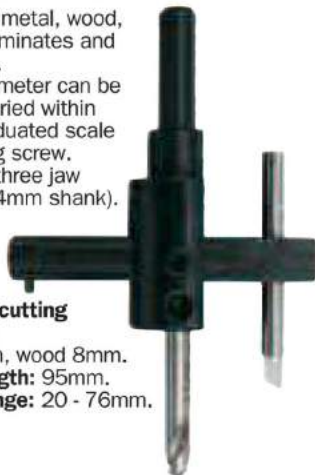

Maximum cutting thickness:
metal 2mm, wood 8mm.
Overall length: 95mm.
Cutting range: 20 - 76mm.

Weight per 6	Order Code
950g	KEN-597
	-4520K

Tacklifter

Beechwood handle, V-cut.



Length	Weight each	Order Code
195mm	100g	KEN-597
		-7150K

SENATOR 18 Piece Drill Set

Supplied in 'dial a drill' case for easy selection.

Sizes: 3, 4, 5, 6, 8 and 10mm.



18
PIECES

6x each drills
Wood, Masonry and HSS



Weight each	Order Code
452g	SEN-025
	-9500K

PRODUCTS ARE ONLY AVAILABLE VIA YOUR DISTRIBUTOR

GROUP
597

WOODWORKING TOOLS

KENNEDY Auger Bits
QUALITY INDUSTRIAL TOOLING



American pattern with solid single twist. Spur point and hexagon shank for use with hand and power tools.



7
PIECES

Boxed Set
Set contents: 6, 9, 13, 16, 19, 22 and 25mm.

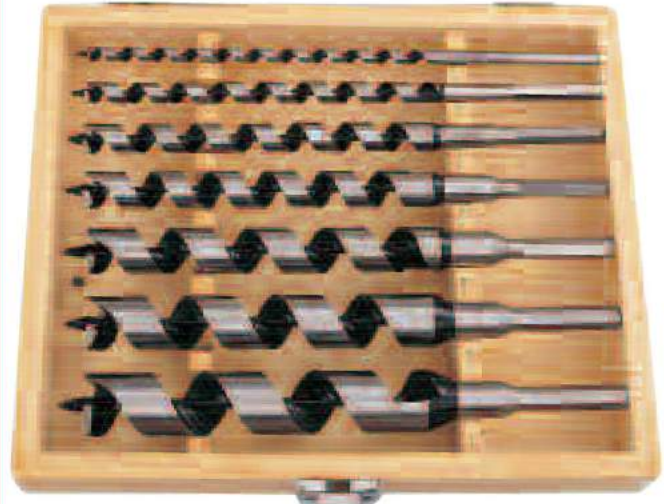

Cutting Dia. (mm)	(Inch)	Overall Length (mm)	Weight each	Order Code KEN-597
6mm Hexagon Shank				
6	1/4"	230	60g	-3030K
7mm Hexagon Shank				
9	3/8"	230	40g	-3070K
13	1/2"	230	130g	-3110K
16	5/8"	230	110g	-3150K
8mm Hexagon Shank				
19	3/4"	230	240g	-3190K
9mm Hexagon Shank				
22	7/8"	230	300g	-3230K
25	1"	230	260g	-3280K

Weight each
860g

Order Code
KEN-597
-3300K

HAND TOOLS

SENATOR Forstner Bits
QUALITY TOOLING

For precision hole boring. Self piloting point combined with trepanning style cutting action will produce overlapping holes in any direction. Ideal for scroll and scalloping applications. Suitable for use in bench and pillar drills to bore a wide range of timber, plastics and other materials.



Boxed Sets
Contents:
5 Piece: 1x each 15, 20, 25, 30 and 35mm.
15 Piece: 1x each 10, 12, 15, 16, 18, 20, 25, 26, 28, 30, 35, 40, 45 and 50mm.

5
PIECES

15
PIECES



Diameter (mm)	Overall Length (mm)	Weight each	Order Code SEN-597
10	90	45g	-5100K
12	90	45g	-5120K
15	90	60g	-5150K
16	90	65g	-5160K
18	90	65g	-5180K
20	90	70g	-5200K
22	90	70g	-5220K
25	90	90g	-5250K
26	90	90g	-5260K
28	90	95g	-5280K
30	90	105g	-5300K
35	90	120g	-5350K
40	90	165g	-5400K
45	90	180g	-5450K
50	90	200g	-5500K

Number of Pieces Weight each Order Code
SEN-597

5 0.70g **-5650K**
15 2.30g **-5670K**

626

PRODUCTS ARE ONLY AVAILABLE VIA YOUR DISTRIBUTOR

SENATOR QUALITY TOOLING 162 Piece Power Bit Set

These Senator® multi-purpose power tool bit set contains a truly comprehensive range of the most commonly used screwdriver bits, nut spinners, Torx bits, drills and adaptors that are suitable for use with hand and power tools. They are supplied in a moulded plastic carry case that has individually storage slots for each piece to ensure you can locate the bit you require easily.

Overall dimensions (W x H x D): 455 x 178 x 297mm.

Set includes:

- 32x 25mm (1") driver bits consisting of: slotted, crosspoint, square, pozi and torx.
- 24x 50mm (2") screwdriver bits consisting of: slotted, crosspoint and torx.
- 18x nut driver bits.
- 5x300mm (12") extra length masonry drills.
- 11x standard length masonry drills.
- 1x screw finder.
- 9x flat wood bits.
- 17x woodworking drills.
- 5x holesaw with mandrel.
- 1x ruler.
- 1x centre punch.
- 1x ratcheting bit driver.
- 4x drill bit depth stop.
- 1x countersink.
- 1x carpenter's pencil.

**162
PIECES**

Weight each	Order Code
3.4kg	SEN-595
	-3180K

SENATOR QUALITY TOOLING Sidewinder Drill

Titanium nitride (TiN) coated for increased tool life and performance. Standard 118° drill point. 6mm shank diameter suitable for use in electric and air powered drills.



The side cutting teeth allow the drill to be used for producing any size or shape of hole in wood or plastic.



Diameter (mm)	Overall Length	Weight each	Order Code
6	90mm	150g	-7500K
8	97mm	150g	-7550K

KENNEDY QUALITY INDUSTRIAL TOOLING Flat Bits

Forged from high quality tool steel with chip clearance groove and hollow ground point. Centerless ground and true running. Ground spade bit head. For cutting holes in laminates and wood. 6mm hexagon shank to prevent slipping at speed.



Cutting Dia. mm	inch	Overall Length	Weight each	Order Code
9	3/8"	160	50g	-4070K
13	1/2"	160	50g	-4110K
16	5/8"	165	55g	-4150K
19	3/4"	170	55g	-4190K
22	7/8"	170	60g	-4230K
25	1"	170	60g	-4280K
32	1 1/4"	170	60g	-4290K

Flat Bit Set

Supplied in wallet.

Contents:

- 9 (3/8"), 13 (1/2"), 16 (5/8"), 19 (3/4"), 22 (7/8") and 25mm (1").

**6
PIECES**

Weight each	Order Code
280g	KEN-597
	-4300K

Adjustable Flat Bits

For cutting holes in wood, plastics etc. Cutting diameter can be infinitely varied within range. Graduated scale with locking screw. For use in three jaw chucks. 9.6mm hexagon shank.

Overall length: 170mm.



Cutting Range	Weight Per 12	Order Code
25 - 45mm	1.8g	-4400K
40 - 76mm	2.8g	-4450K

PRODUCTS ARE ONLY AVAILABLE VIA YOUR DISTRIBUTOR