

# PRODUCT TECHNICAL DATASHEET

# BE20/200/HS

Encoder 

24V 

Brushless 



CODICE	DESCRIZIONE	PZ/PALLET
<b>BE20/200/HS</b>	Electromechanical actuator BRUSHLESS HIGH SPEED, low voltage, super intensive use, with native encoder onboard, irreversible, ideal for swing gates with leaf up to 2,5 mt length, with mechanical stopper in opening and closing.	50

SPECIFICHE TECNICHE PRODOTTO	
Power line supply	230V AC - 50Hz
Motor power supply	36V
Power rating	200W
Frequency of use	Intensive use
Thrust	100 - 2200N
Operating temperature	-20 C° +55 C°
Protection level	IP43
Reductor Type	Irreversible
Manoeuvre speed	3 cm/s
Opening time at 90°	10-15 s
Stroke	400 mm
Limit switch	Mechanical stopper in opening and closing
Encoder	Digital native encoder SENSORLESS 48 PPR
Operating cycles per day (opening/closing - 24 hours no stop)	800
Maximum dimension product in mm (L x W x H)	867 x 105 x 155
Product weight packed (Kg)	8
Number items per pallet	50

# DIMENSIONI

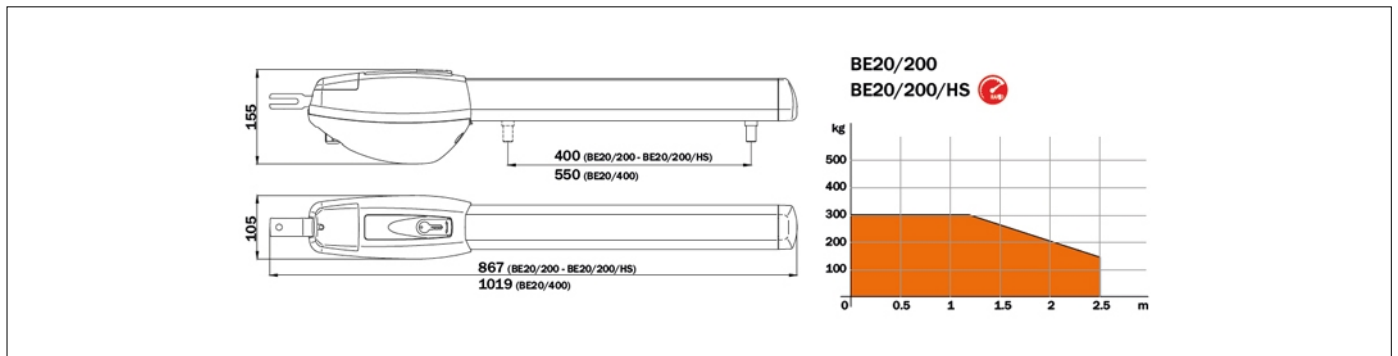

DIMENSIONS

# PREDISPOSIZIONI INSTALLAZIONE STANDARD

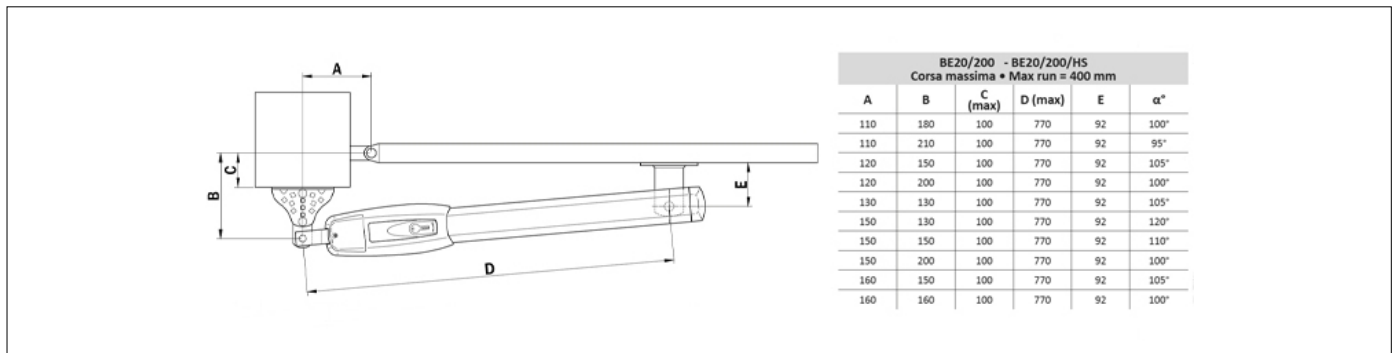

PREDISPOSITION FOR STANDARD INSTALLATION

# PRODOTTI ACCESSORI

<b>MC781</b> Kit 2 mechanical stop BR20, BE20 series, R20/300MS and R20/500MS.	<b>KT202</b> Short front hinge plate, to weld.	<b>KT204</b> Short rear hinge plate, to weld.	<b>KT206</b> Kit 3 hinge plates short, to weld.	<b>KT206/R</b> Kit of screw-adjustable short rear bracket and screw-welded short front bracket.	<b>R99/C/001</b> Signboard Automatic Opening*.