

Fixed Displacement Vane Pump

HV and HVQ Series



Features

- HV / HVQ Series are fixed displacement and balanced type vane pumps. Available in both 12 vanes design for industrial application with quiet operating and 10 vanes design for mobile application with higher pressure and wider range of speed.
- The vane design with self compensation for wear and clearances makes volumetric efficiency of pump nearly constant over the service life. (the vane always adjust its orbit to contact with the cam ring, even though wear occurs between the cam ring and vane tip)
- With a balanced intra-vane design, outlet pressure is continuously applied only to the area between the vane and insert. This area is small and thrust is correspondingly light. Top and bottom areas of the vane are subject to either inlet or outlet pressure, depending on the vane's location during rotor rotation. The valving of pressure to and from the bottom area of the vane is through holes drilled in the rotor. This varying pressure under the vane reduces wear and increases pump efficiency.
- The vane pump is not damaged at low speed and high pressure operation because pumping action does not start until the speed is high enough for the vane to throw out.



- The inlet or outlet ports can be rotated through increments of 90° in relation to each other, providing application flexibility and easy installation.
- With the cartridge independent of the shaft, allowing for easy change of flow capacity and field servicing without removing the pump from its mounting.
- For the cartridge kit of HVQ Series, the flexible plates are inserted between the support plates and the rotor. The flexible plates are assembled with the bronze facing towards the rotor to improve cold start capability and compensate thermal expansion in the rotor. This makes HVQ Series particularly suited for mobile application.

Handling

- For maximum service life, the pump should be protected from contamination. Filtering fluid before filling and during operation to maintain or exceed ISO cleanliness code 16/13. Appropriately size suction filter, with cold start bypass, of 149 micron absolute (100 mesh) and 10 micron absolute return line filter is recommended. Replaceable elements should be changed as filter supplier instructions
- The drive shaft must align with the power source shaft. Avoiding shaft end thrust and applications that impose radial loading.
- The start-up procedures should be as follows:
 - Check the rotation of power source to match with rotation of pump.

- Check inlet and outlet ports to assure all connections are properly installed and check all mounting bolts and flanges to assure all are tight and properly aligned.
- Fill pump with fluid through the outlet port if the pump is mounted above the fluid level. The spline shaft models also need to be lubricate with an anti-fretting grease or similar lubricant.
- Place all controls in the neutral position so the pump is unloaded during initial start-up.
- Prime the pump within a few second when the pump is started.
- Bleed off entrapped air from outlet circuit until a steady output flow is observed.

The products described herein, including without limitation, product features, specifications, designs, availability and pricing, are subject to change at any time without notice.

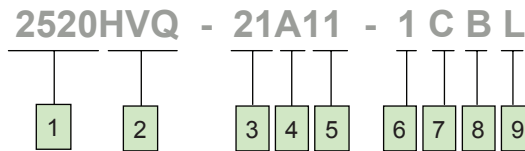

- 1** Model
2520, 3520, 4520
3525, 4525, 4535
- 2** Series
HV - Industrial
HVQ - Mobile
- 3** Shaft End Pump
Ring Size (USgpm)
2520HV/HVQ - 12, 14, 17, 19, 21
3525HV/HVQ - 21, 25, 30, 35, 38
4520, 4525, 4535HV/HVQ - 42, 47, 50, 57, 60
- 4** Port Connection
A - SAE 4-bolt with Inch threads
AM - SAE 4-bolt with Metric threads
- 5** Cover End Pump
Ring Size (USgpm)
2520HV/HVQ - 2, 5, 8, 9, 11, 12, 14
3525, 4525HV/HVQ - 12, 14, 17, 19, 21
4535HV/HVQ - 21, 25, 30, 35, 38
- 6** Shaft
1 - Straight keyed
11 - Splined
86 - Heavy duty straight keyed
- 7** Shaft End Outlet Port position
(Viewed from cover end)
A - Opposite inlet
B - 90° CCW from inlet
C - Inline with inlet
D - 90° CW from inlet
- 8** Cover End Outlet Port position
(Viewed from cover end)
For all models except 4535HV/HVQ
A - 135° CCW from inlet
B - 45° CCW from inlet
C - 45° CW from inlet
D - 135° CW from inlet
For 4535HV/HVQ
A - Opposite inlet
B - 90° CCW from inlet
C - Inline with inlet
D - 90° CW from inlet
- 9** Shaft Rotation
(Viewed from shaft end)
R - Turn right
L - Turn left

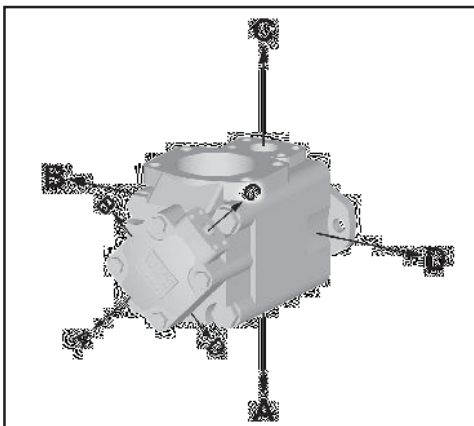

Port Positions for 2520HV/HVQ, 3520HV/HVQ
4520HV/HVQ, 3525HV/HVQ, 4525HV/HVQ

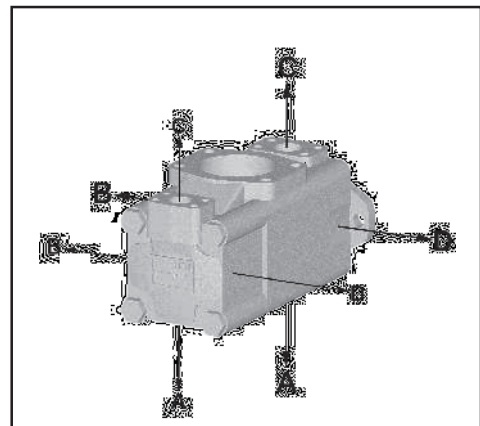

Port Positions for 4535HV/HVQ

Specifications
Double Pump HV Series

Model	Cartridge Position	Delivery at 1200 rpm & 7 bar (100 psi)	Displacement	Maximum Speed	Maximum Pressure	Typical Delivery at max speed & pressure	Typical Input Power at max speed & pressure	Weight
		USgpm	cm ³ /r (in ³ /r)	rpm	bar (psi)	L/min (USgpm)	kW (hp)	
2520HV	Shaft End	12	39 (2.47)	1800	172 (2500)	62.1 (16.4)	22.9 (30.8)	20 (45)
		14	45 (2.78)			69.6 (18.4)	25.7 (34.5)	
		17	55 (3.39)			86.3 (22.8)	29.8 (40.0)	
		19	60.8 (3.72)			91.6 (25.4)	32.5 (43.5)	
		21	67 (4.13)			106.0 (28.0)	34.0 (45.6)	
	Cover End	2	7.0 (0.42)	206 (3000)	11.3 (3.00)	5.2 (7.0)		
		5	18 (1.10)	206 (3000)	28.4 (7.5)	11.2 (15.0)		
		8	27 (1.67)	206 (3000)	45.4 (12.0)	17.0 (22.8)		
		9	30.2 (1.84)	206 (3000)	51.0 (13.5)	23.5 (31.5)		
		11	36 (2.22)	206 (3000)	56.8 (15.0)	22.6 (30.3)		
3520HV	Shaft End	21	68.3 (4.18)	1800	172 (2500)	106.3 (28.1)	33.9 (45.5)	34 (75)
		25	81 (4.94)			124.9 (33.0)	45.5 (61.0)	
		30	97 (5.91)			154.4 (40.8)	54.5 (73.0)	
		35	112 (6.83)			181.7 (48.0)	61.5 (82.4)	
		38	121 (7.37)			193.8 (51.2)	65.9 (88.3)	
	Cover End	2	7.0 (0.42)	206 (3000)	11.3 (3.00)	5.2 (7.0)		
		5	18 (1.10)	206 (3000)	28.4 (7.5)	11.2 (15.0)		
		8	27 (1.67)	206 (3000)	45.4 (12.0)	17.0 (22.8)		
		9	30.2(1.84)	206 (3000)	51.0 (13.5)	23.5 (31.5)		
		11	36 (2.22)	206 (3000)	56.8 (15.0)	22.6 (30.3)		
3525HV	Shaft End	21	68.3 (4.18)	1800	172 (2500)	106.3 (28.1)	33.9 (45.5)	34.5 (76)
		25	81 (4.94)			124.9 (33.0)	45.5 (61.0)	
		30	97 (5.91)			154.4 (40.8)	54.5 (73.0)	
		35	112 (6.83)			181.7 (48.0)	61.5 (82.4)	
		38	121 (7.37)			193.8 (51.2)	65.9 (88.3)	
	Cover End	12	39 (2.47)	206 (3000)	11.3 (3.00)	5.2 (7.0)		
		14	45 (2.78)	206 (3000)	28.4 (7.5)	11.2 (15.0)		
		17	55 (3.39)	206 (3000)	45.4 (12.0)	17.0 (22.8)		
		19	68.3 (3.72)	206 (3000)	51.0 (13.5)	23.5 (31.5)		
		21	67 (4.13)	206 (3000)	56.8 (15.0)	22.6 (30.3)		
4520HV	Shaft End	42	138 (8.41)	1800	172 (2500)	208.2 (55.0)	75.3 (101.0)	43 (94)
		47	151.4 (9.26)			244.1 (64.5)	82.5 (110.6)	
		50	162 (9.85)			253.6 (67.0)	87.3 (117.0)	
		57	183.6 (11.23)			295.0 (77.8)	94.0 (126.0)	
		60	193 (11.75)			310.4 (82.0)	103.7 (139.0)	
	Cover End	2	7.0 (0.42)	206 (3000)	11.3 (3.00)	5.2 (7.0)		
		5	18 (1.10)	206 (3000)	28.4 (7.5)	11.2 (15.0)		
		8	27 (1.67)	206 (3000)	45.4 (12.0)	17.0 (22.8)		
		9	30.2 (1.84)	206 (3000)	51.0 (13.5)	23.5 (31.5)		
		11	36 (2.22)	206 (3000)	56.8 (15.0)	22.6 (30.3)		
4525HV	Shaft End	42	138 (8.41)	1800	172 (2500)	208.2 (55.0)	75.3 (101.0)	46 (101)
		47	151.4 (9.26)			244.1 (64.5)	82.5 (110.6)	
		50	162 (9.85)			253.6 (67.0)	87.3 (117.0)	
		57	183.6 (11.23)			295.0 (77.8)	94.0 (126.0)	
		60	193 (11.75)			310.4 (82.0)	103.7 (139.0)	
	Cover End	12	39 (2.47)	206 (3000)	11.3 (3.00)	5.2 (7.0)		
		14	45 (2.78)	206 (3000)	28.4 (7.5)	11.2 (15.0)		
		17	55 (3.39)	206 (3000)	45.4 (12.0)	17.0 (22.8)		
		19	60.8 (3.72)	206 (3000)	51.0 (13.5)	23.5 (31.5)		
		21	67 (4.13)	206 (3000)	56.8 (15.0)	22.6 (30.3)		
4535HV	Shaft End	42	138 (8.41)	1800	172 (2500)	208.2 (55.0)	75.3 (101.0)	54 (118)
		47	151.4 (9.26)			244.1 (64.5)	82.5 (110.6)	
		50	162 (9.85)			253.6 (67.0)	87.3 (117.0)	
		57	183.6 (11.23)			295.0 (77.8)	94.0 (126.0)	
		60	193 (11.75)			310.4 (82.0)	103.7 (139.0)	
	Cover End	21	68.3 (4.18)	206 (3000)	11.3 (3.00)	5.2 (7.0)		
		25	81 (4.94)	206 (3000)	28.4 (7.5)	11.2 (15.0)		
		30	97 (5.91)	206 (3000)	45.4 (12.0)	17.0 (22.8)		
		35	112 (6.83)	206 (3000)	51.0 (13.5)	23.5 (31.5)		
		38	121 (7.37)	206 (3000)	56.8 (15.0)	22.6 (30.3)		

Specifications

Double Pump HVQ Series

Model	Cartridge Position	Delivery at 1200 rpm & 7 bar (100 psi)	Displacement	Maximum Speed	Maximum Pressure	Typical Delivery at max speed & pressure	Typical Input Power at max speed & pressure	Weight
		USgpm	cm ³ /r (in ³ /r)	rpm	bar (psi)	L/min (USgpm)	kW (hp)	
2520HVQ	Shaft End	12	40 (2.45)	2500	206 (3000)	87.1 (23.0)	41.0 (55.0)	20 (45)
		14	45 (2.77)			102.2 (27.0)	46.6 (62.5)	
		17	55 (3.37)			117.3 (31.0)	51.8 (69.5)	
		19	60.8 (3.72)			130.5 (34.50)	53.0 (71.0)	
		21	67 (4.12)			143.8 (38.0)	61.9 (83.0)	
	Cover End	2	7.0 (0.42)	2700	206(3000)	15.9 (4.2)	7.3 (9.8)	
		5	18 (1.10)		206 (3000)	37.9 (10.0)	16.4 (22.0)	
		8	27 (1.67)		206 (3000)	60.6 (16.0)	24.2 (32.5)	
		9	30.2 (1.84)		206 (3000)	71.5 (18.9)	32.9 (44.1)	
		11	36 (2.22)		206 (3000)	79.5 (21.0)	32.8 (44.0)	
3520HVQ	Shaft End	21	68.3 (4.18)	2500	206 (3000)	143.8 (38.0)	55.0 (73.9)	34 (75)
		25	81 (4.98)			145.7 (38.5)	66.4 (89.0)	
		30	97 (5.96)			177.9 (47.0)	77.6 (104.0)	
		35	112 (6.88)			208.2 (55.0)	89.5 (120.0)	
		38	121 (7.42)			223.3 (59.0)	97.0 (130.0)	
	Cover End	2	7.0 (0.42)	2500	206 (3000)	15.0 (4.0)	6.1 (8.2)	
		5	18 (1.10)		206 (3000)	37.9 (10.0)	16.4 (22.0)	
		8	27 (1.67)		206 (3000)	60.6 (16.0)	24.2 (32.5)	
		9	30.2 (1.84)		206 (3000)	67.8 (17.9)	27.5 (36.8)	
		11	36 (2.22)		206 (3000)	79.5 (21.0)	32.8 (44.0)	
3525HVQ	Shaft End	21	68.3 (4.18)	2500	206 (3000)	143.8 (38.0)	55.0 (73.9)	34.5 (76)
		25	81 (4.98)			145.7(38.5)	66.4(89.0)	
		30	97 (5.96)			177.9 (47.0)	77.6 (104.0)	
		35	112 (6.88)			208.2 (55.0)	89.5 (120.0)	
		38	121 (7.42)			223.3 (59.0)	97.0 (130.0)	
	Cover End	12	40 (2.45)	2500	206 (3000)	79.5 (21.0)	38.0 (51.0)	
		14	45 (2.77)			90.8 (24.0)	43.3 (58.0)	
		17	55 (3.37)			117.3 (31.0)	51.5 (69.0)	
		19	60.8 (3.72)			130.5 (34.50)	53.0 (71.0)	
		21	67 (4.12)			143.8 (38.0)	61.9 (83.0)	
4520HVQ	Shaft End	42	138 (8.46)	2200	172 (2500)	251.7(66.5)	91.4 (122.5)	43 (94)
		47	151.4 (9.26)			280.8 (74.2)	95.0 (127.3)	
		50	162 (9.90)			299.0 (79.0)	105.2 (141.0)	
		57	183.6 (11.23)			342.5 (90.5)	109.3 (146.6)	
		60	193 (11.80)			363.4 (96.0)	126.8 (170.0)	
	Cover End	2	7.0 (0.42)	2200	206 (3000)	13.6 (3.6)	5.6 (7.5)	
		5	18 (1.10)		206 (3000)	32.2 (8.5)	14.5 (19.5)	
		8	27 (1.67)		206 (3000)	51.1 (13.5)	21.3 (28.5)	
		9	30.2 (1.84)		206 (3000)	59.7 (15.7)	24.2 (32.5)	
		11	36 (2.22)		206 (3000)	68.1 (18.0)	28.7 (38.5)	
4525HVQ	Shaft End	42	138 (8.46)	2200	172 (2500)	251.7(66.5)	91.4(122.5)	46(101)
		47	151.4 (9.26)			280.8 (74.2)	95.0 (127.3)	
		50	162 (9.90)			299.0 (79.0)	105.2 (141.0)	
		57	183.6 (11.23)			342.5 (90.5)	109.3 (146.6)	
		60	193(11.80)			363.4(96.0)	126.8(170.0)	
	Cover End	12	40 (2.45)	2200	206 (3000)	68.1(18.0)	32.8 (44.0)	
		14	45 (2.77)			79.5 (21.0)	38.0 (51.0)	
		17	55 (3.37)			100.3(26.5)	45.5(61.0)	
		19	60.8 (3.72)			120.6 (31.8)	48.8 (69.5)	
		21	67 (4.12)			124.9(33.0)	54.5 (73.0)	
4535HVQ	Shaft End	42	138 (8.46)	2200	172 (2500)	251.7 (66.5)	91.4 (122.5)	54 (118)
		47	151.4 (9.26)			280.8 (74.2)	95.0 (127.3)	
		50	162 (9.90)			299.0 (79.0)	105.2 (141.0)	
		57	183.6 (11.23)			342.5 (90.5)	109.3 (146.6)	
		60	193 (11.80)			363.4 (96.0)	126.8 (170.0)	
	Cover End	21	68.3 (4.18)	2200	206 (3000)	128 (33.8)	51.9 (69.5)	
		25	81 (4.98)			145.7 (38.5)	66.4 (89.0)	
		30	97 (5.96)			177.9 (47.0)	77.6 (104.0)	
		35	112 (6.88)			208.2 (55.0)	89.5 (120.0)	
		38	121 (7.42)			223.3 (59.0)	97.0 (130.0)	

2520HV/HVQ for shaft, see 25HV/HVQ

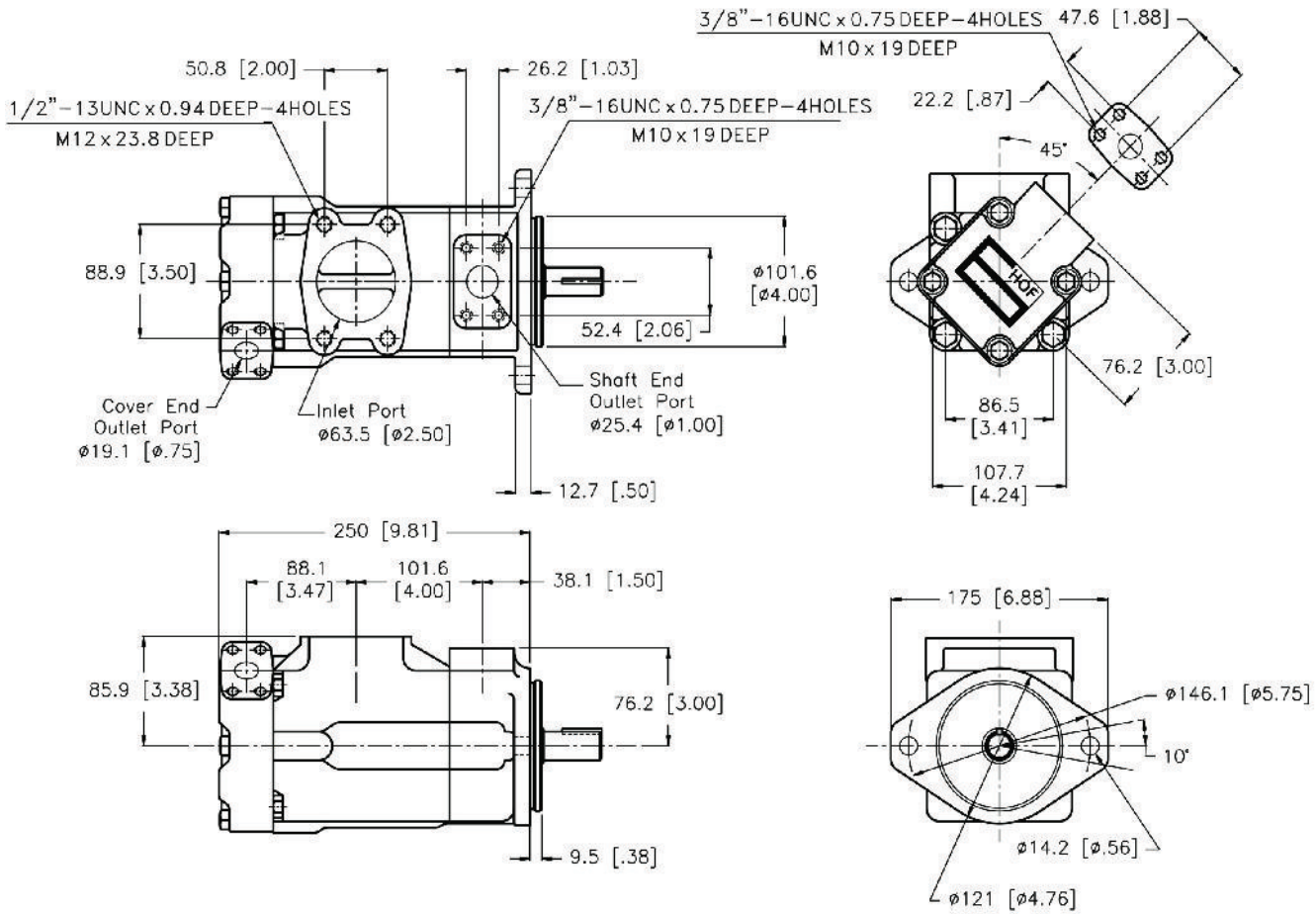

3520HV/HVQ for shaft, see 35HV/HVQ

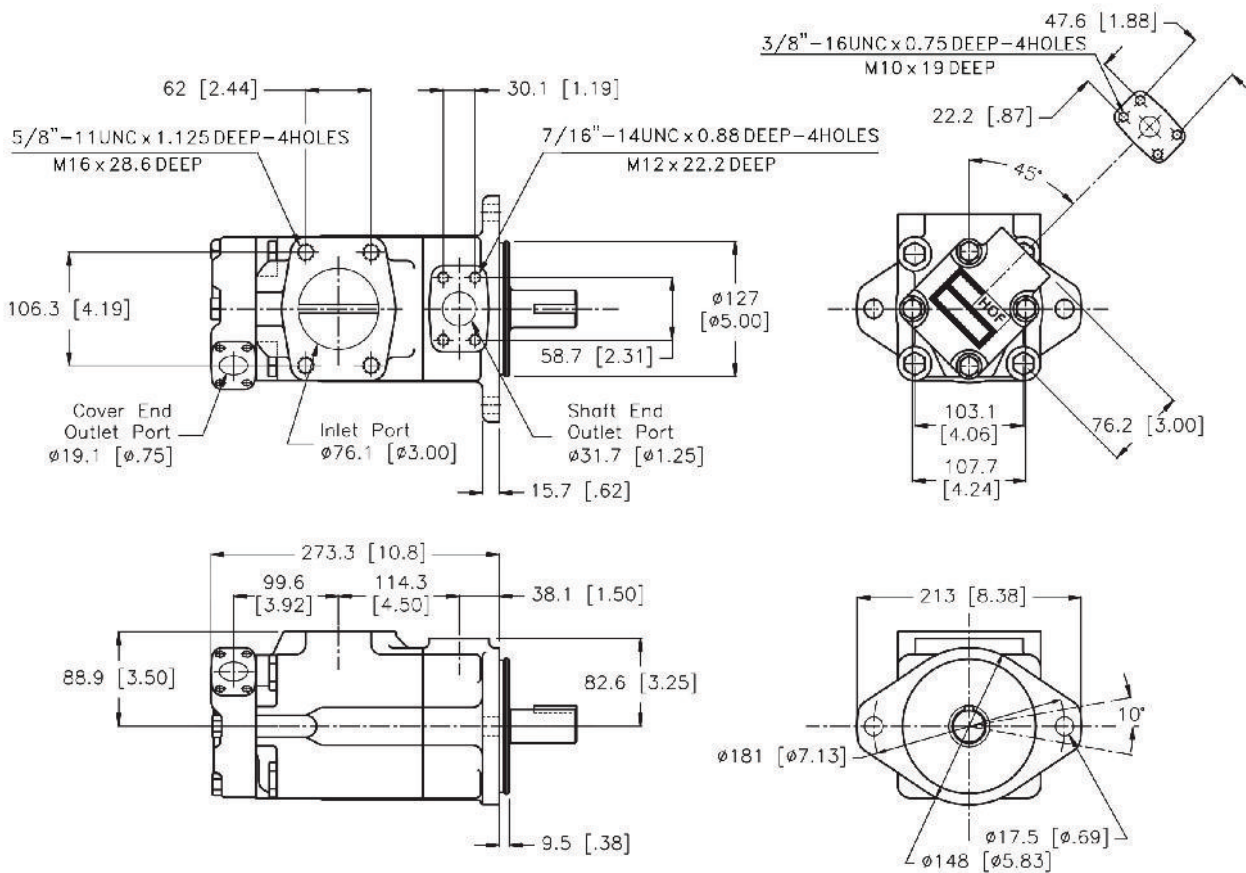

3525HV/HVQ for shaft, see 35HV/HVQ

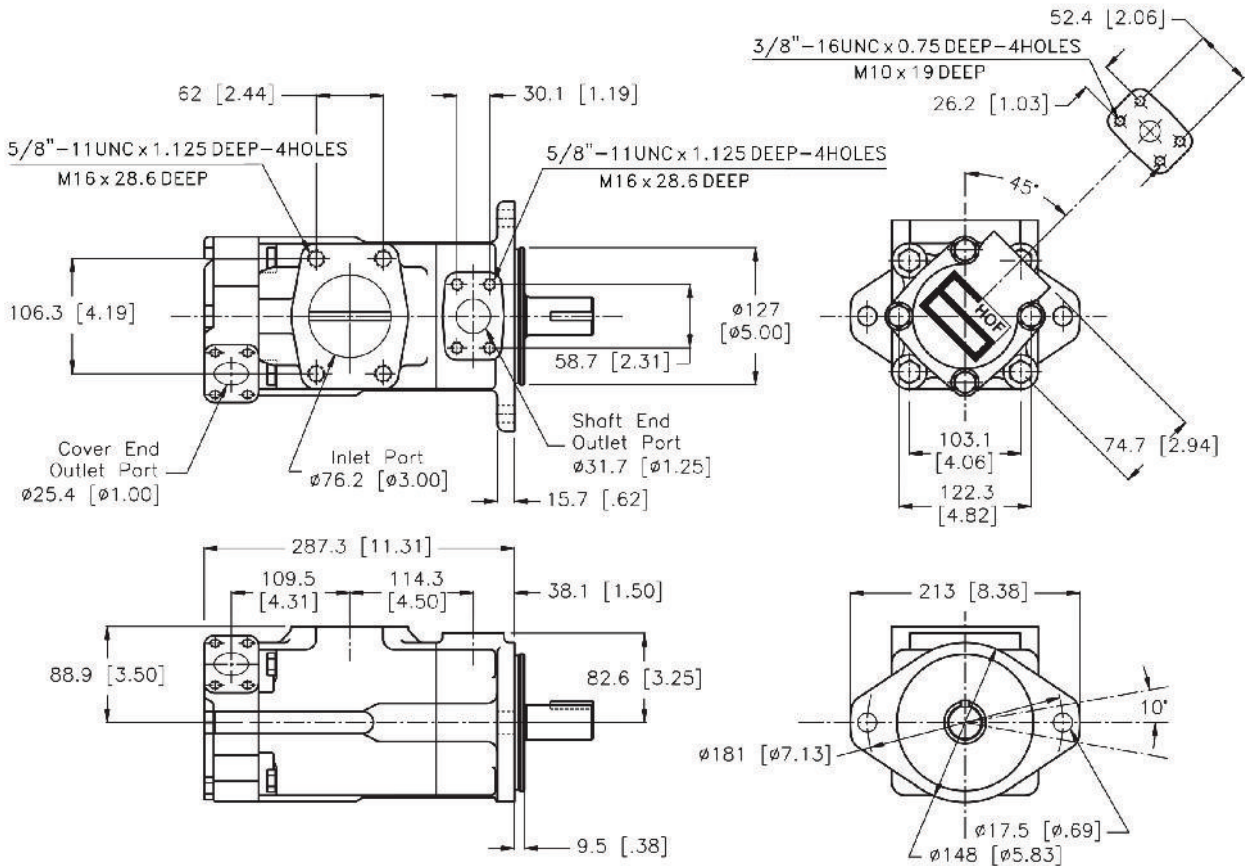

4520HV/HVQ for shaft, see 45HV/HVQ

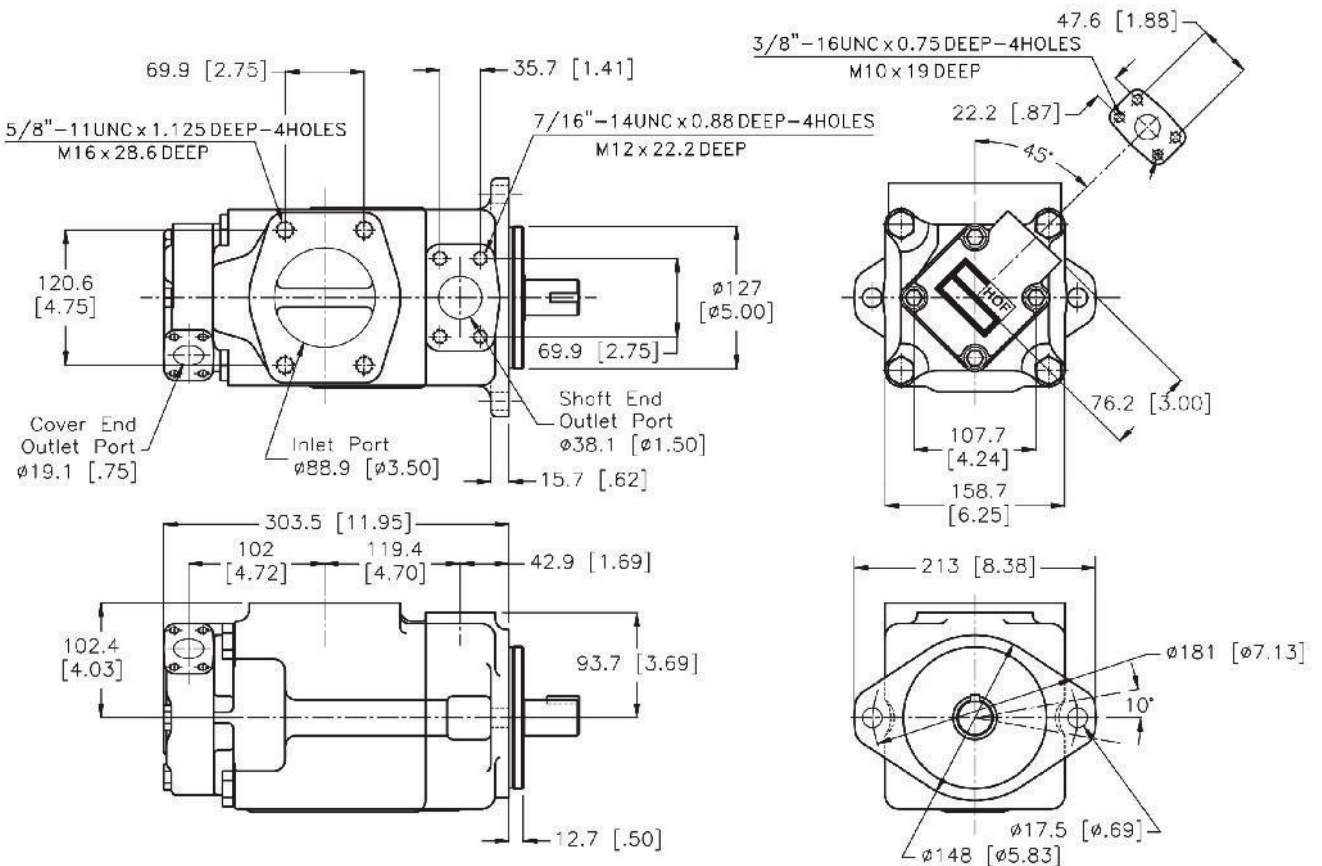

4525HV/HVQ for shaft, see 45HV/HVQ

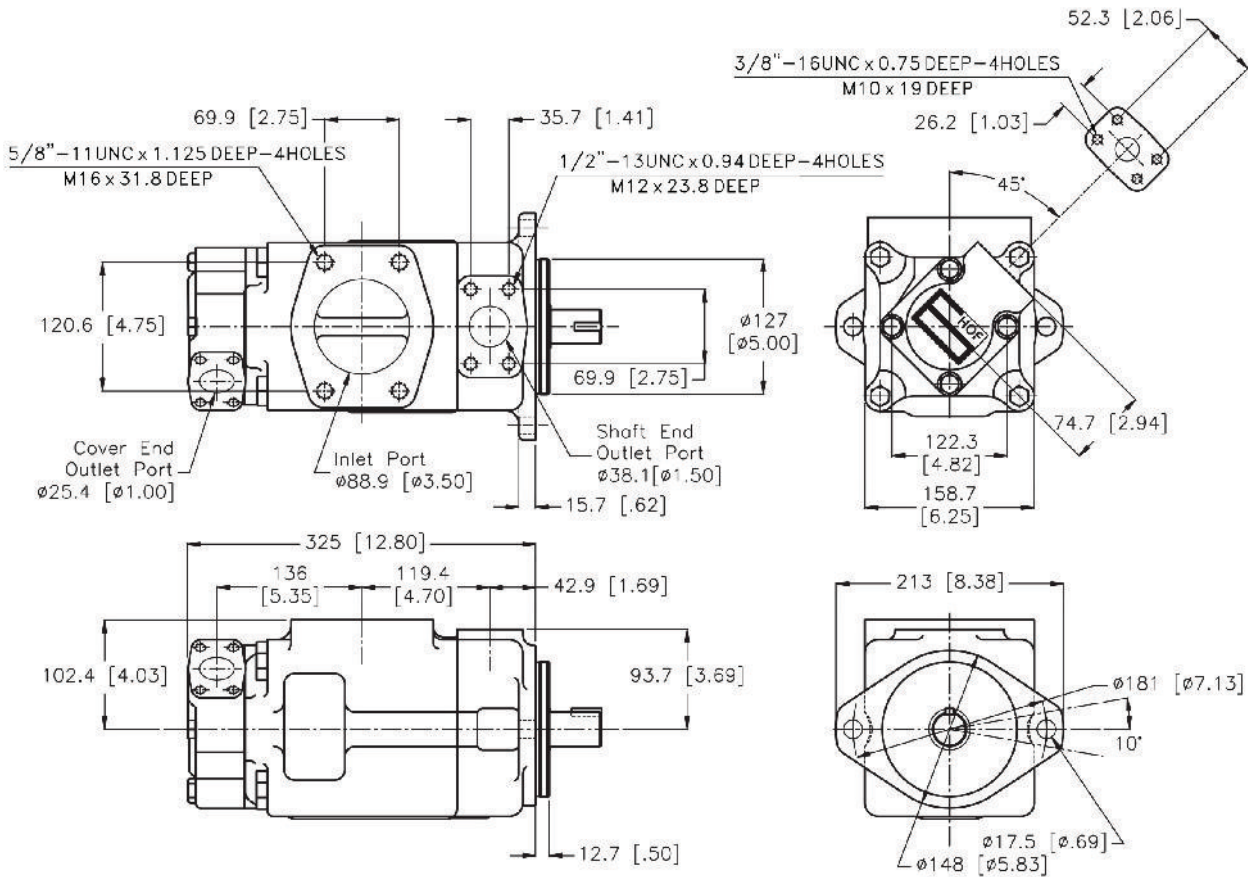

4535HV/HVQ for shaft, see 45HV/HVQ

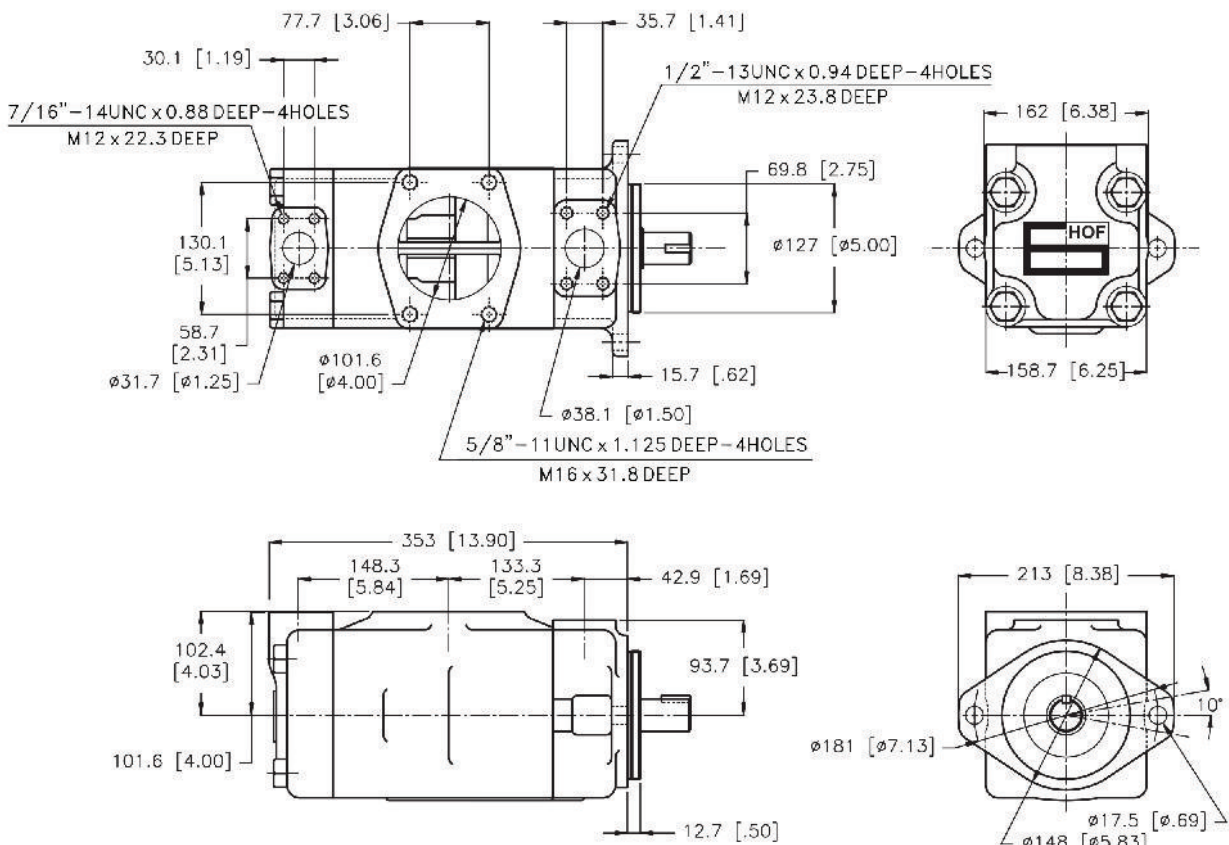

Based on SAE 10W Fluid at 50 °C (120 °F) and Pump inlet at 0 PSIG (14.7 PSIA)

At 1200 rpm

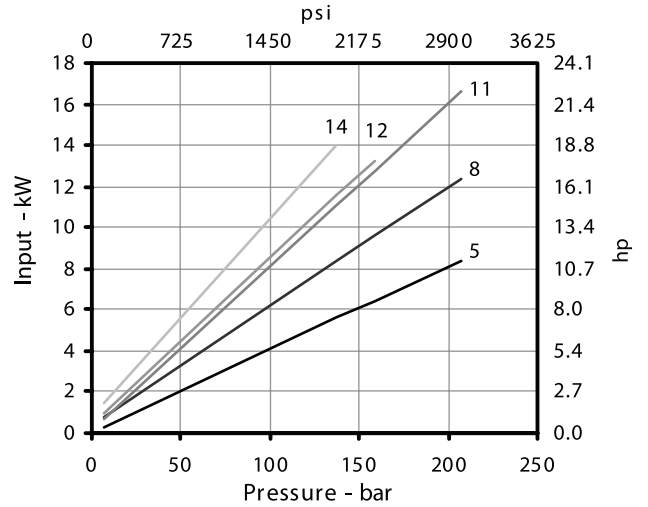
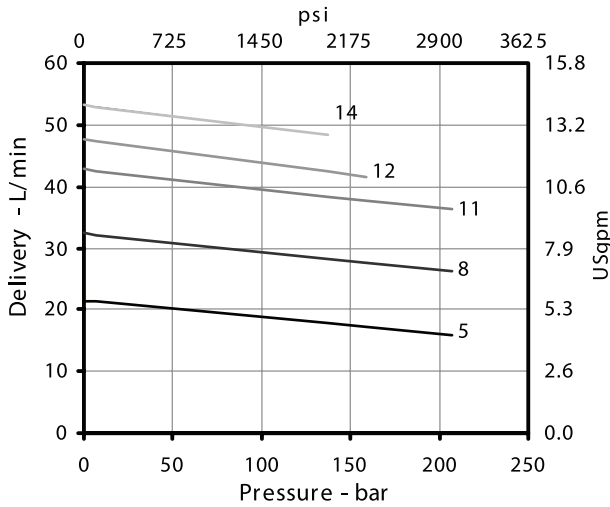

At 1500 rpm

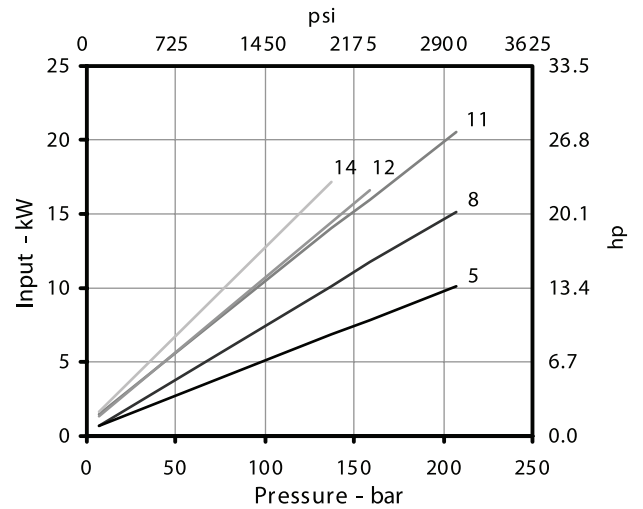
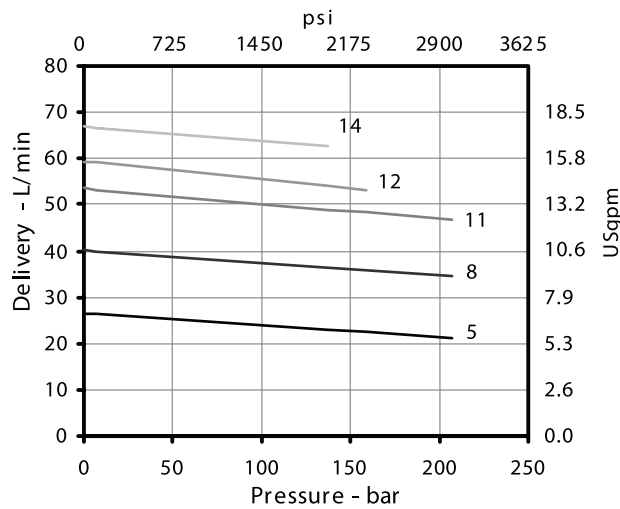

At 1800 rpm

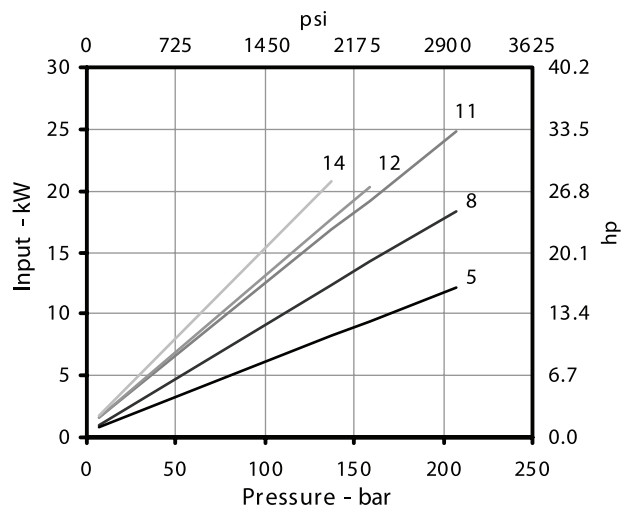
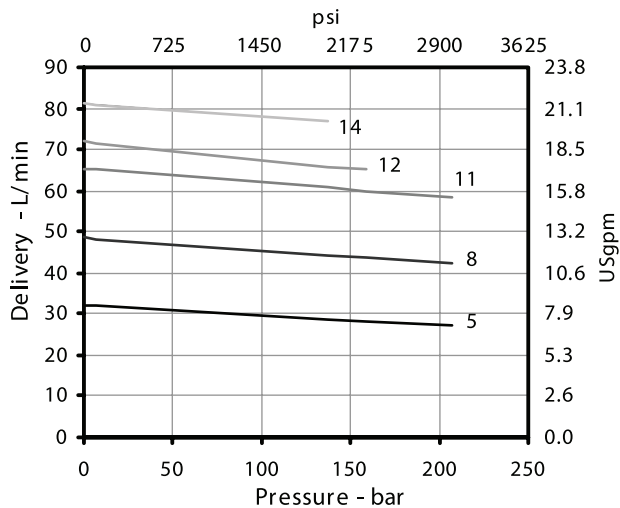

Based on SAE 10W Fluid at 50 °C (120 °F) and Pump inlet at 0 PSIG (14.7 PSIA)

At 1200 rpm

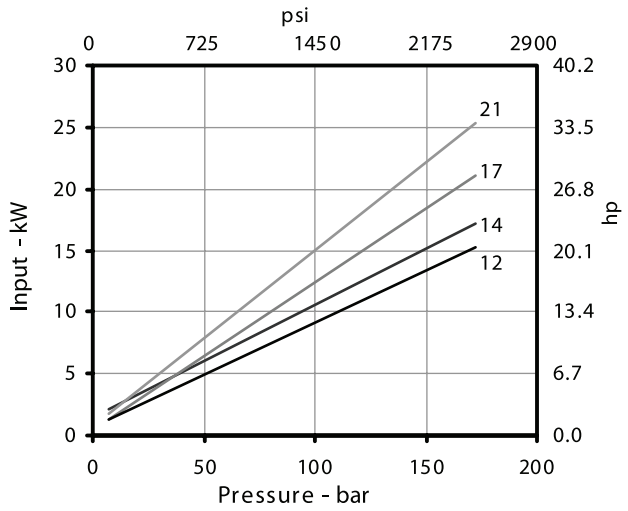
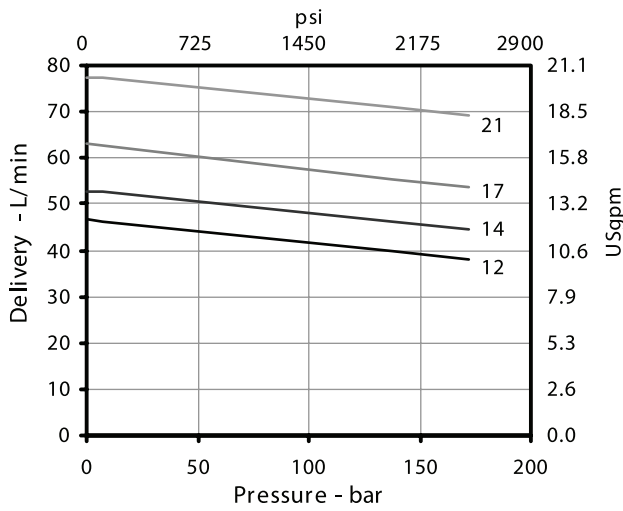

At 1500 rpm

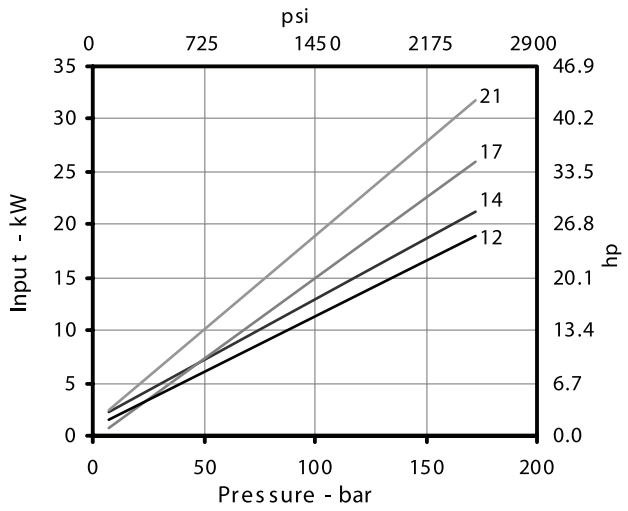
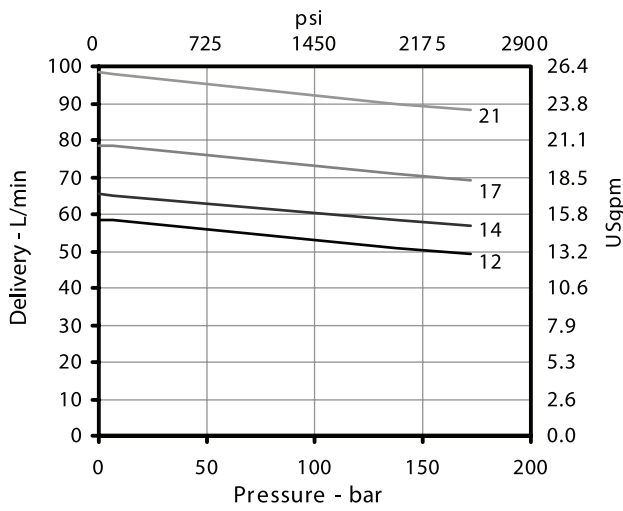

At 1800 rpm

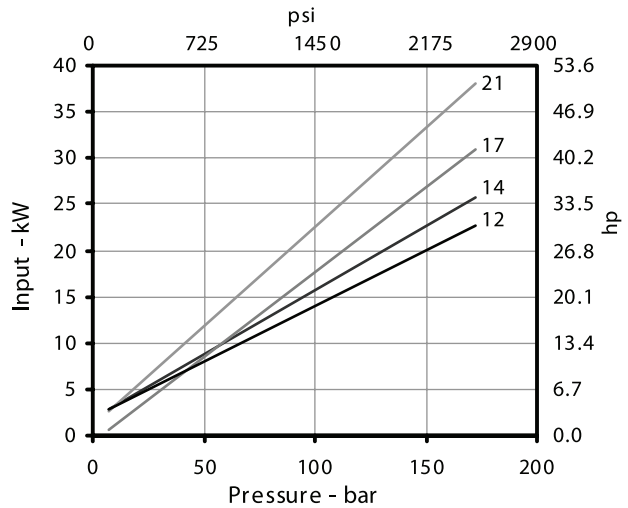
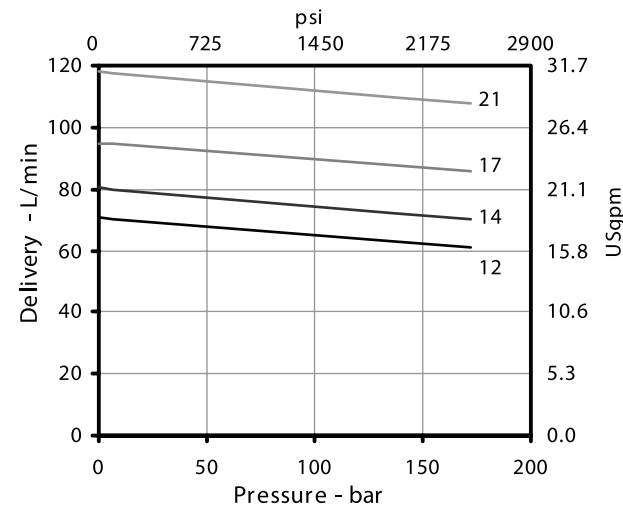

Based on SAE 10W Fluid at 50 °C (120 °F) and Pump inlet at 0 PSIG (14.7 PSIA)

At 1200 rpm

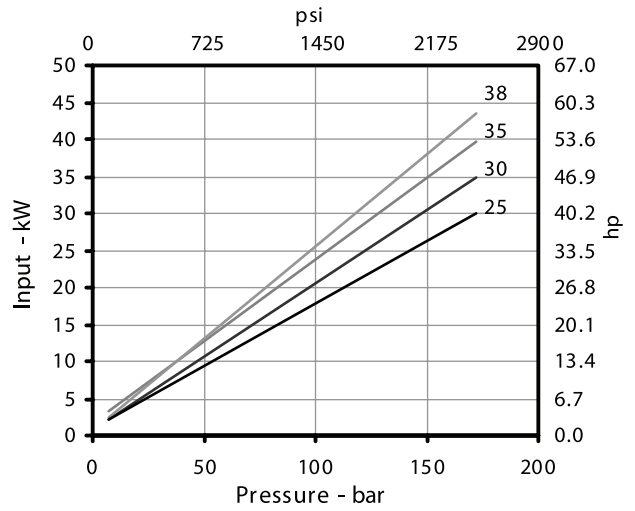
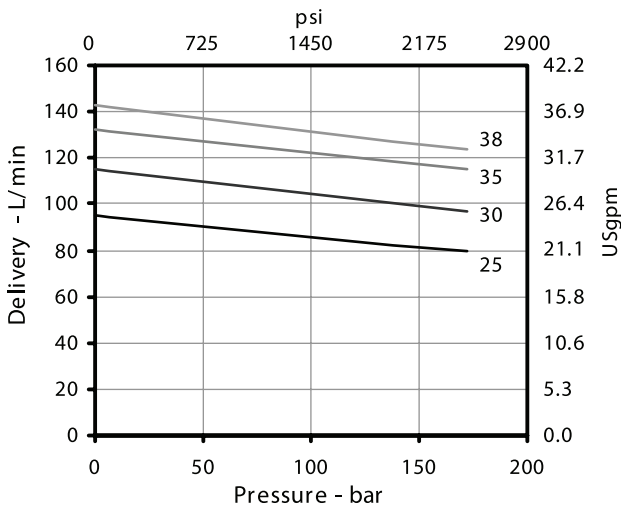

At 1500 rpm

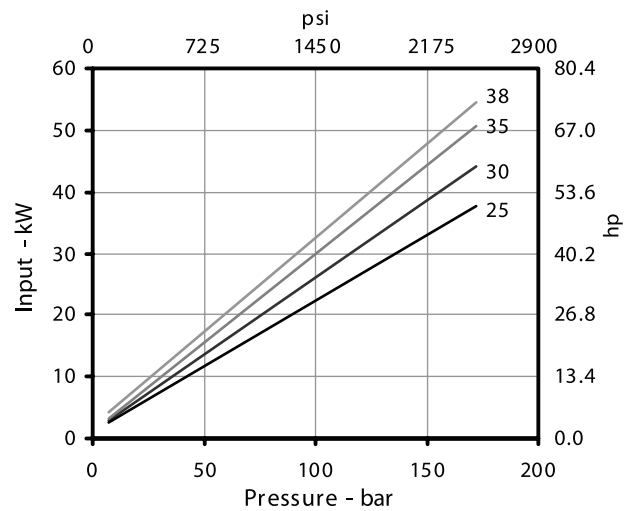
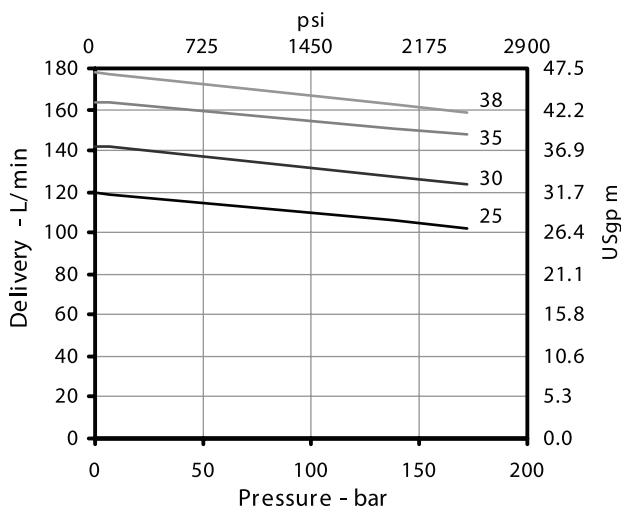

At 1800 rpm

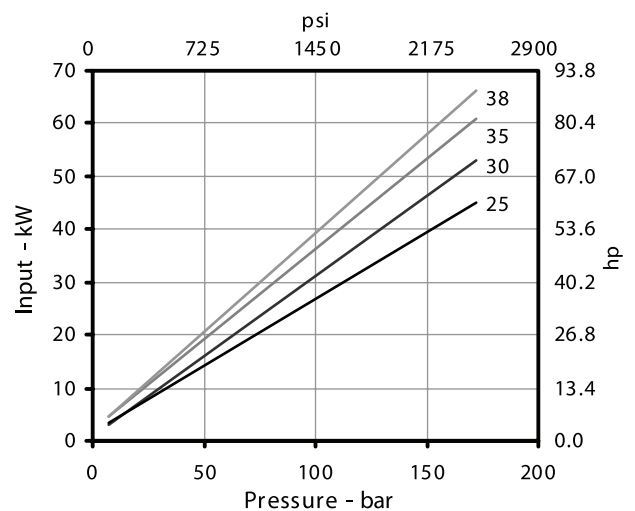
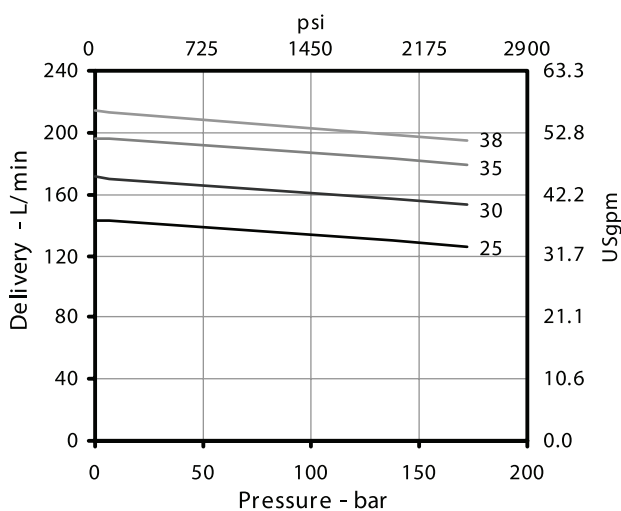

Based on SAE 10W Fluid at 50 °C (120 °F) and Pump inlet at 0 PSIG (14.7 PSIA)

At 1200 rpm

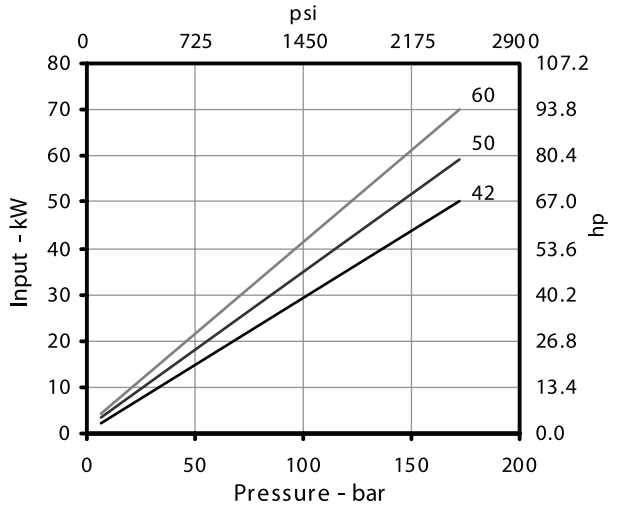
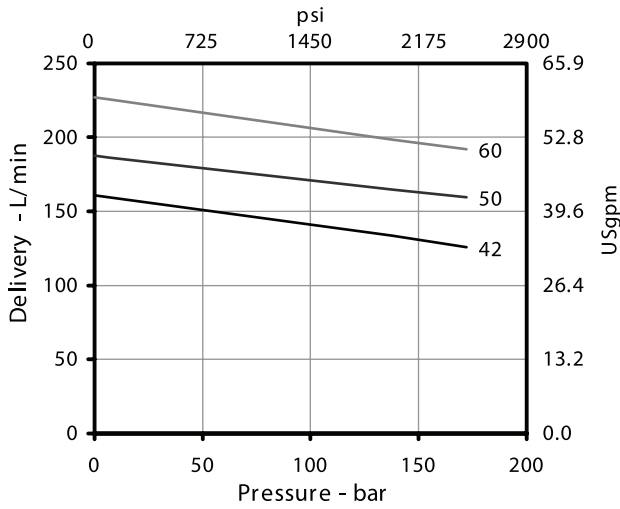

At 1500 rpm

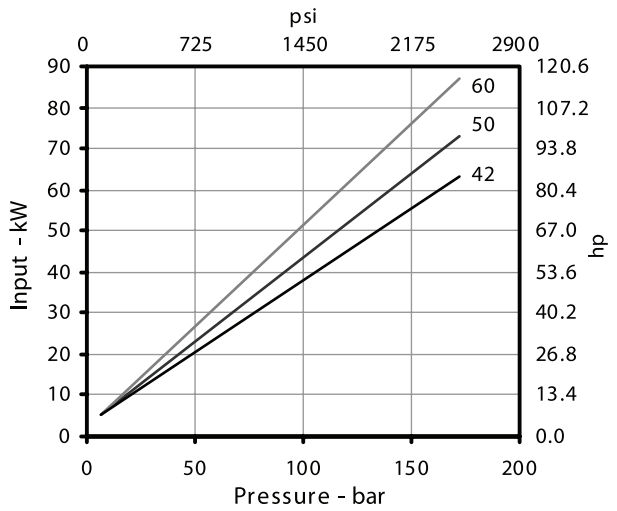
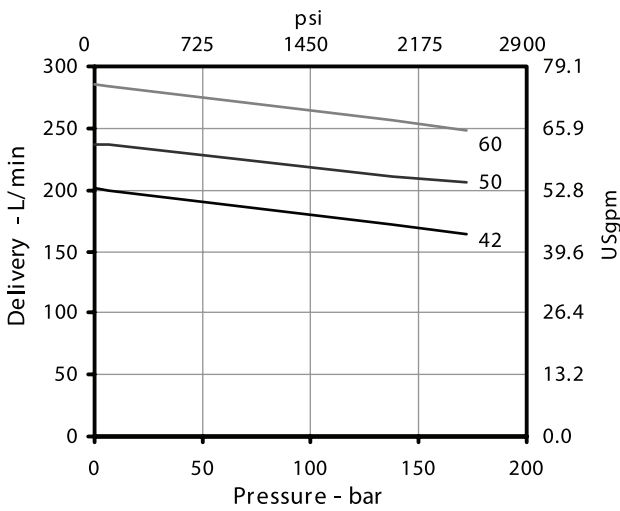

At 1800 rpm

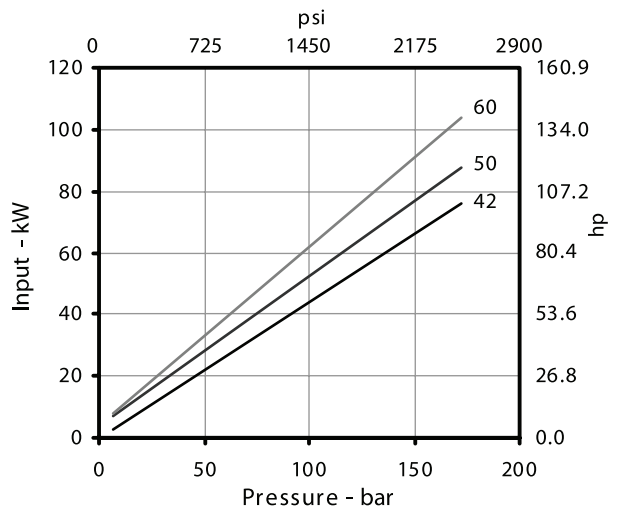
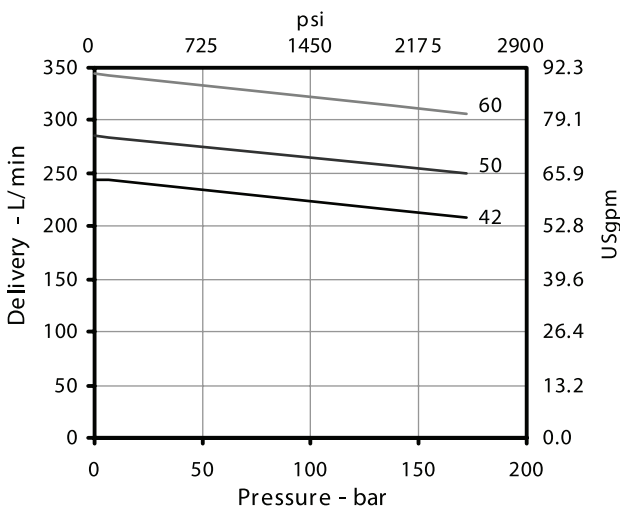

Based on SAE 10W Fluid at 82 °C (180 °F) and Pump inlet at 0 PSIG (14.7 PSIA)

Size 5, 8

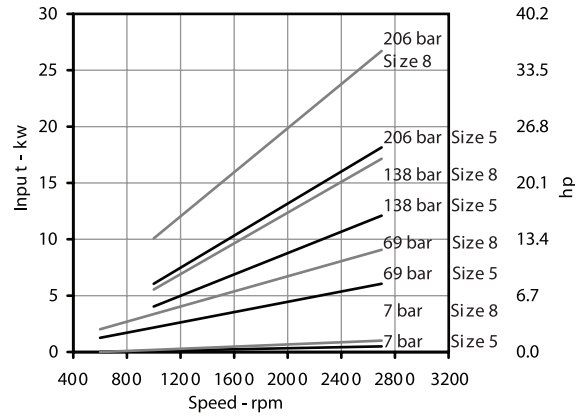
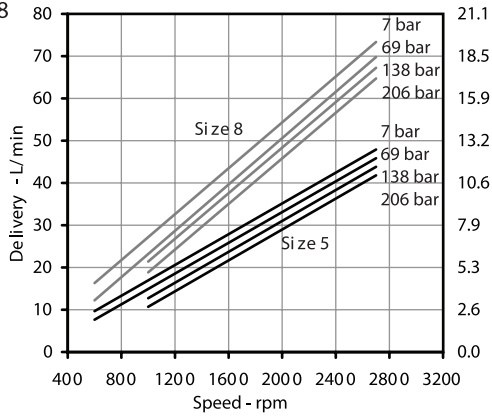

Size 11

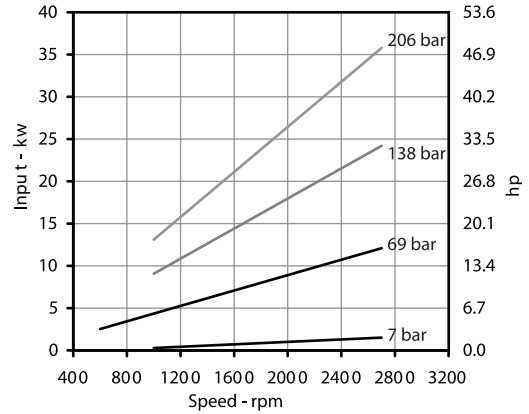
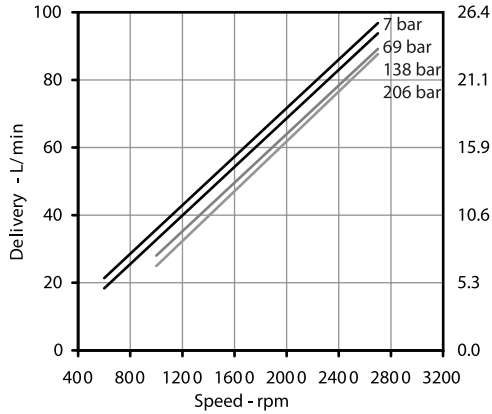

Size 12

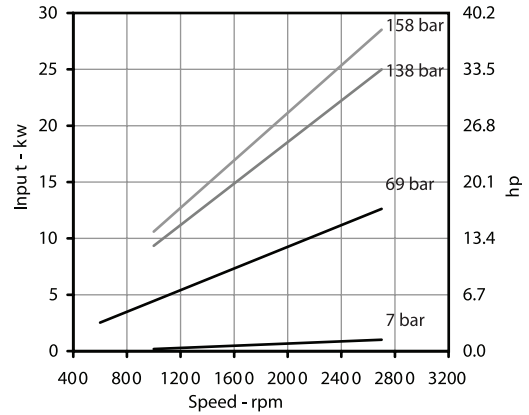
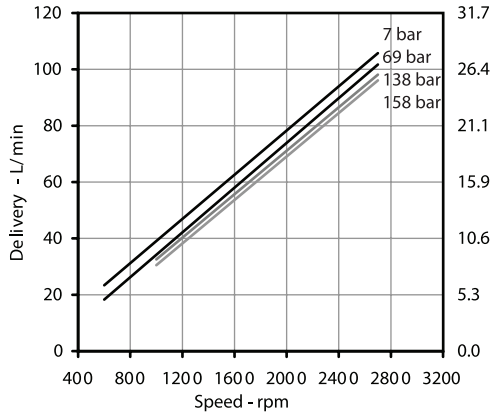

Size 14

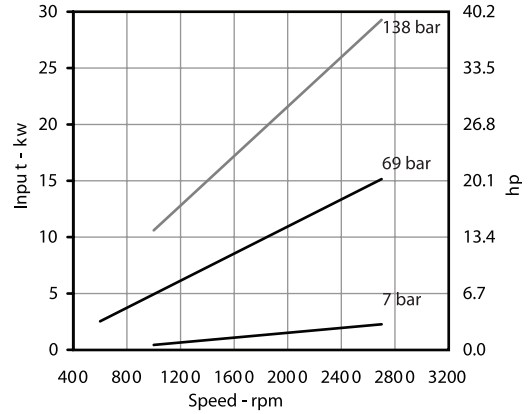
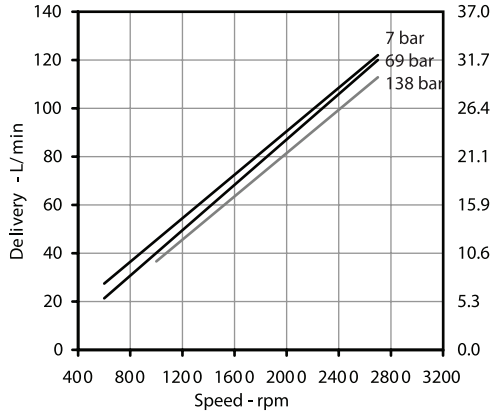

For the Cover End Cartridge, the speed could not exceed the maximum speed of the Shaft End Cartridge.

Based on SAE 10W Fluid at 82 °C (180 °F) and Pump inlet at 0 PSIG (14.7 PSIA)

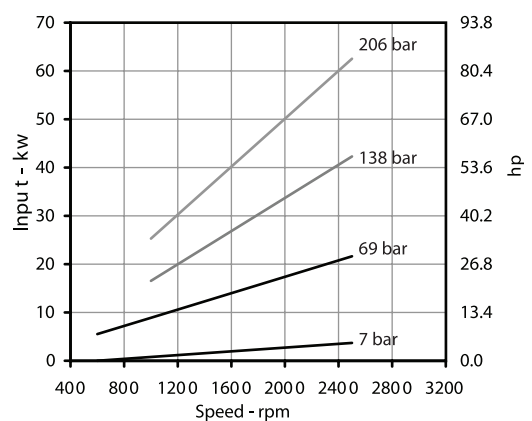
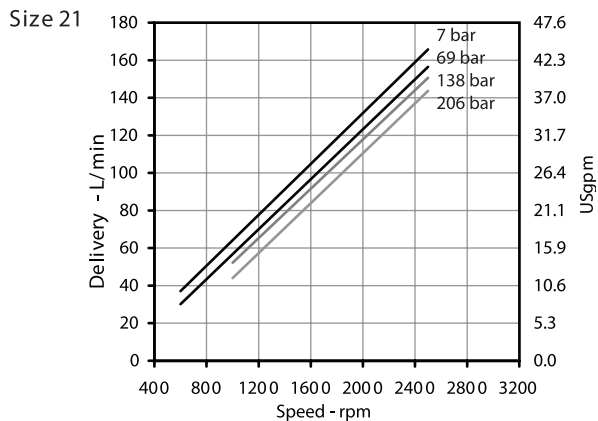
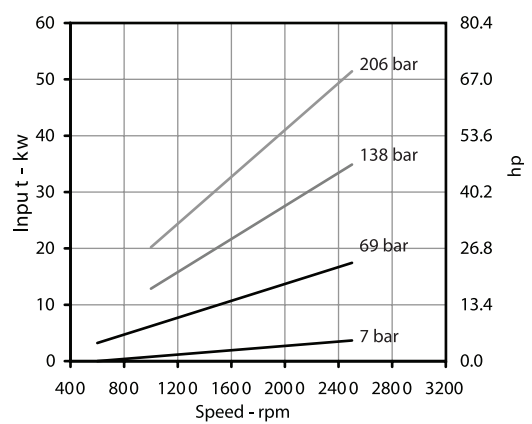
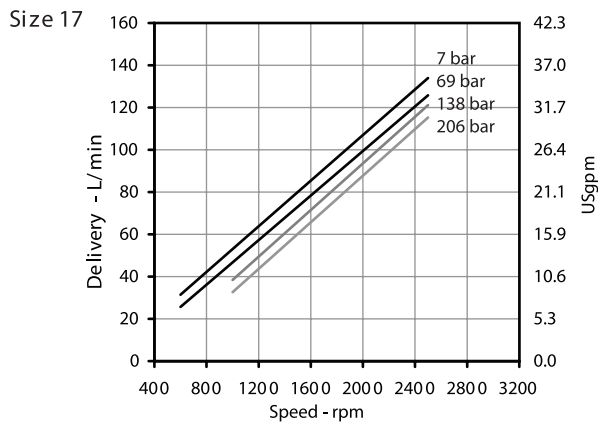
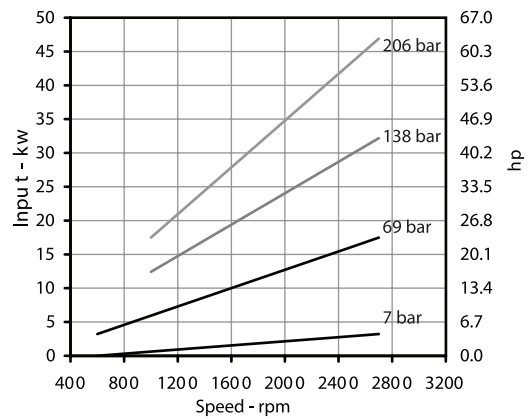
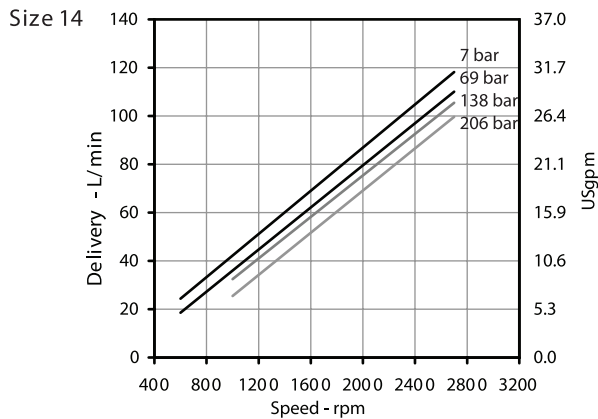
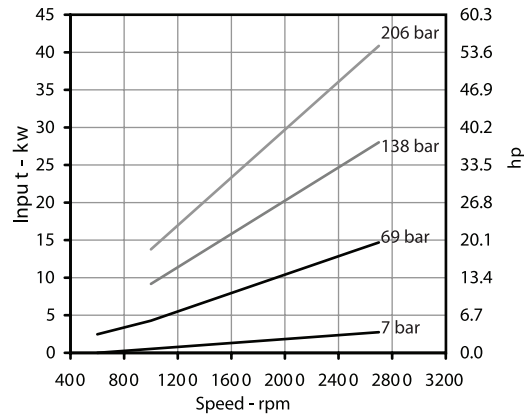
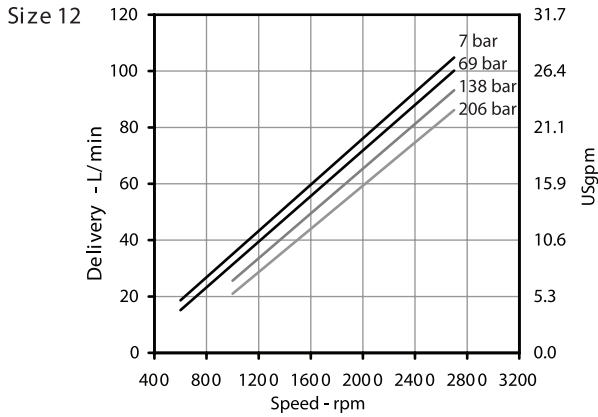

For the Cover End Cartridge, the speed could not exceed the maximum speed of the Shaft End Cartridge.

Based on SAE 10W Fluid at 82 °C (180 °F) and Pump inlet at 0 PSIG (14.7 PSIA)

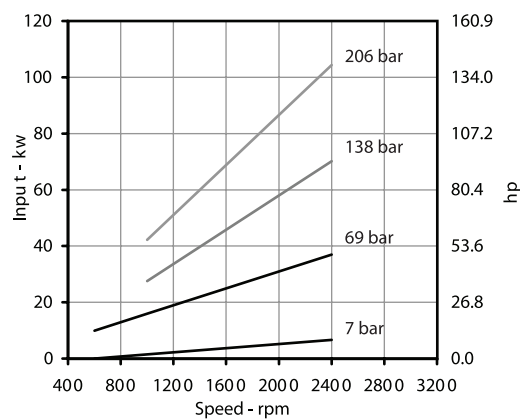
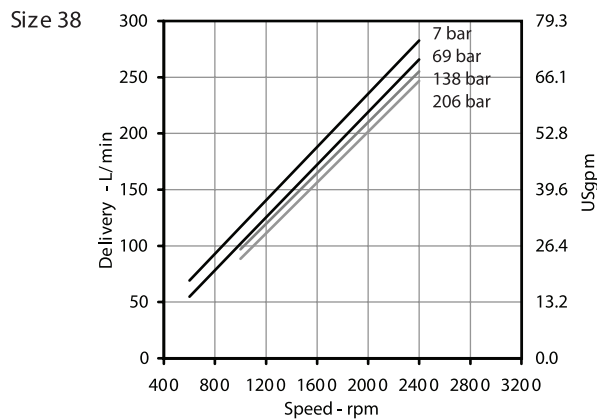
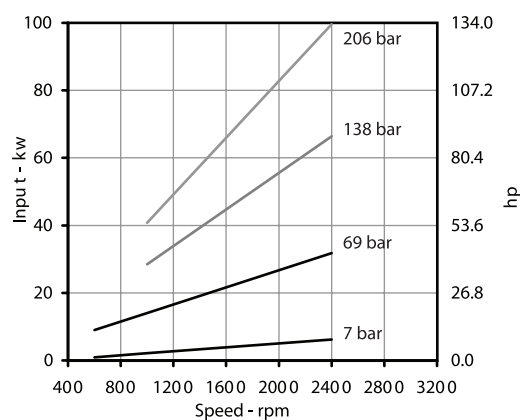
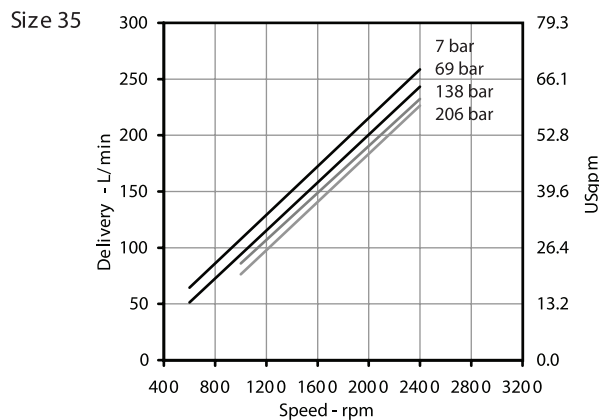
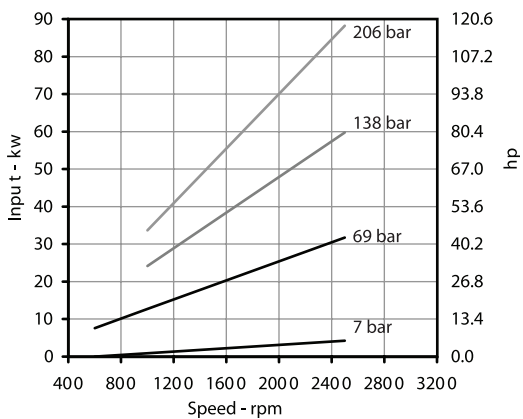
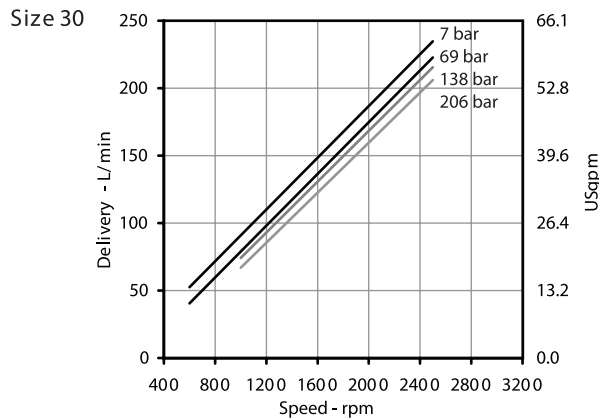
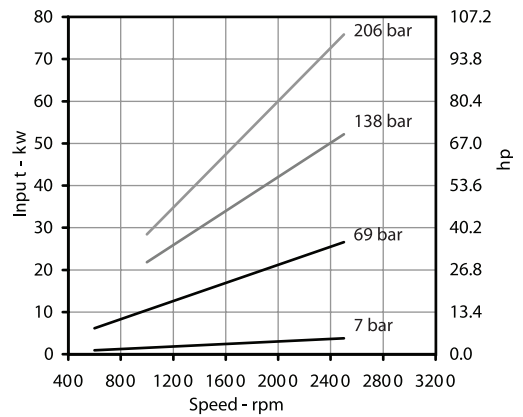
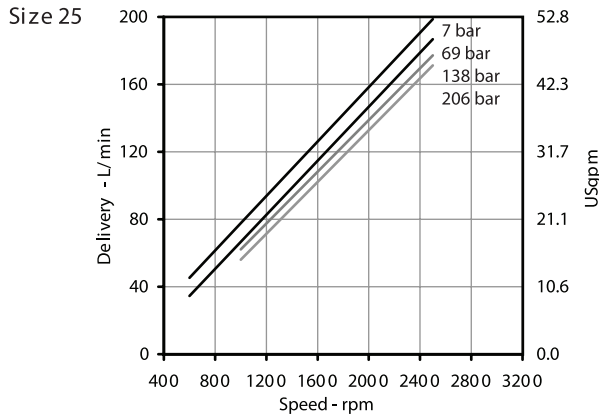

For the Cover End Cartridge, the speed could not exceed the maximum speed of the Shaft End Cartridge.

Based on SAE 10W Fluid at 82 °C (180 °F) and Pump inlet at 0 PSIG (14.7 PSIA)

