



ATI Robotic End Effectors.
Engineered Excellence.



Why the best manufacturers on Earth **choose ATI.**

In 1989, ATI set out to produce the best robotic productivity tools available. Our dedication to that quest has resulted in the most reliable and flexible line of Robotic End Effectors in the industry. Today, the mission continues as we develop leading-edge products that enhance robotic productivity. To that end, every resource at our disposal is devoted to making ATI products into the ultimate productivity tools.

Driven by engineering excellence.

The driving force behind our success is the ATI research and development team, the largest of its kind in the world for Robotic End Effectors. Our accomplished mechanical, electrical and software engineers continue to raise the bar in quality, innovation and productivity. Our dedication to engineering excellence has resulted in the most flexible and adaptable line of products on the market today for both standard and custom applications.



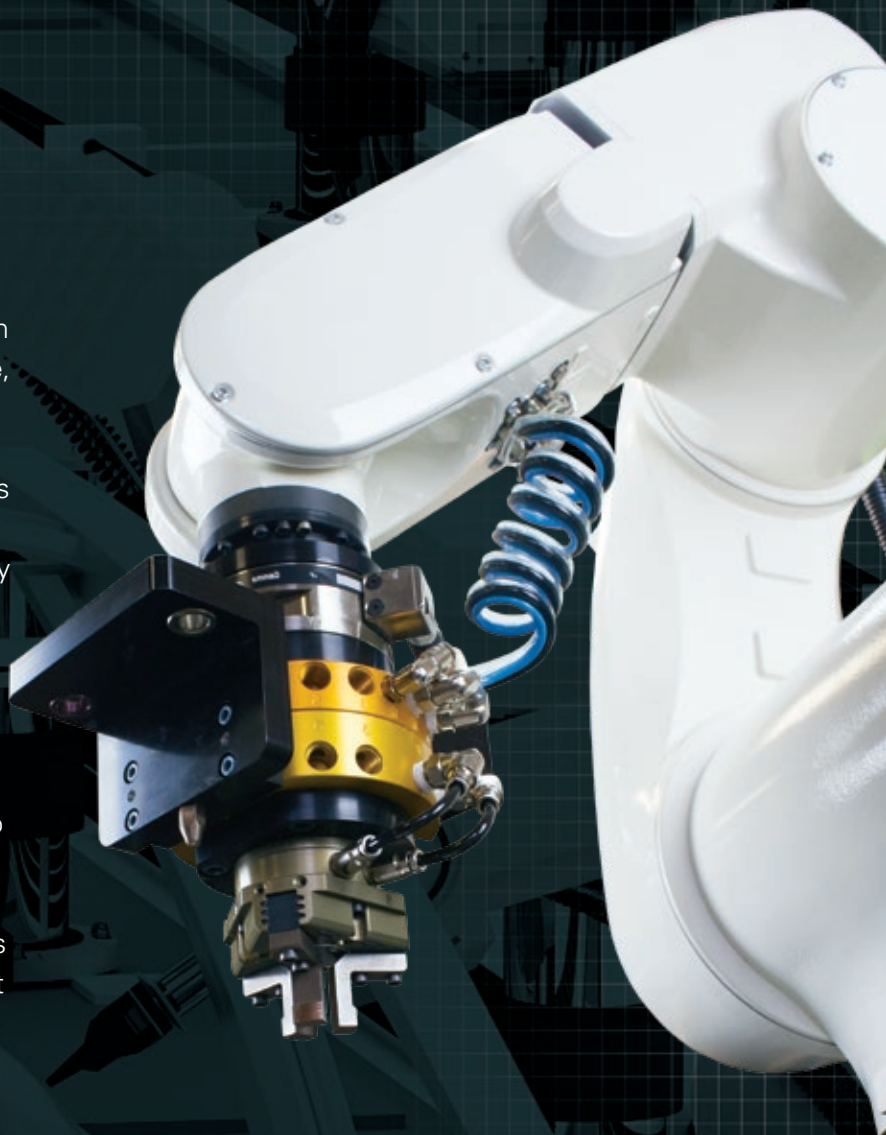

A world leader in Robotic End Effectors.

Recognized throughout the world for quality and reliability, ATI products are improving productivity in an array of industries, including Robotics, Aerospace, Biomedical, Automotive, Electronics, Applied Research, Academics, Nuclear and Governmental. Our ISO 9001 registration assures that ATI products meet the most stringent industry standards for quality. Each product is subjected to rigorous quality assurance and inspection guidelines before it can leave the factory.

ATI solutions. When nothing less will do.

If the quest for excellence in robotic productivity made us the industry leader, it is our dedication to the customer that has kept us there. Customer satisfaction is priority one at ATI, and it all begins with listening. Experienced ATI Account Managers work closely with your staff to achieve the perfect fit for your specific application. This consultative sales style, combined with our family of standard and customizable products, ensures that you always get the best product for your application. Your success is our top priority.

The following pages offer a brief look at the industry's most reliable Robotic End Effector products. But it's just the beginning. To learn more about how ATI can help you in your quest to improve robotic productivity, call **919.772.0115** to connect with an ATI Account Manager or visit **www.ati-ia.com**.

Contents

Robotic Tool Changers	4
Force/Torque Sensors	16
Material Removal Tools	22
Utility Couplers	28
Manual Tool Changers	32
Robotic Collision Sensors	34
Compliance Devices	38



Robotic Tool Changers Strong, secure, and safe.

Product Description

ATI's Robotic Tool Changers are robust pneumatic devices that connect end-of-arm tooling to a robot securely and promote a safer work environment. The Robotic Tool Changer brings flexibility to robot applications by allowing the robot to change end-effectors (e.g., grippers, vacuum cup tooling, pneumatic and electric motors, weld guns, etc.) automatically.



The Master plate is installed on the robot arm and locks to the

Tool plate with a pneumatically-driven locking mechanism. This locking mechanism features our patented multi-taper cam design and fail-safe ball-lock technology.

The Tool plate, mounted to the end-effector, interfaces with the Master plate's pneumatic locking mechanism to connect the tooling securely to the robot arm. Once the Master plate and Tool plate are coupled, utilities are passed through the Tool Changer to the robot tooling. One Master plate can interface with any number of Tool plates.

Why use a Robotic Tool Changer?

Advantages of using Robotic Tool Changer include:

- Increased productivity in robotic applications.
- Automatic exchange of end-effectors.
- Deployment of multiple end-effectors in one cycle.
- Hands-free changeover for increased operator safety.
- Flexibility to support a wide array of pass-through utilities.

ATI Robotic Tool Changers feature unique attributes such as:

Superior Fail-safe Locking: The locking mechanism includes a patented fail-safe feature that keeps the Tool plate secured to the Master plate in the event of pneumatic pressure loss. This fail-safe feature eliminates the need for a spring.

High Rigidity: Due to the locking piston's large diameter and aggressive cam taper, the Robotic Tool Changer has a high moment capacity to withstand vibration and high-inertia movement.

Unmatched Repeatability: The piston aligns the master and tool plates reliably and securely every time. Product durability has been proven by our customers through years of field observation and analysis.

No-Touch Locking: The No-Touch design allows robot operators to easily teach pick and drop points by overcoming small gaps and misalignments between the mating surfaces, thus minimizing wear and tear and eliminating the need for complicated tool storage systems.

Integrated Features: Tool stand hooks, lock and unlock sensors, and tool changer mounting patterns for common robot models, make the tool changer compact and easy to integrate.



ATI has a Tool Changer for any robot payload from 1.4 kg (QC-1) to 4080 kg (QC-1510).

ATI Tool Changer Locking Mechanism

Our patented fail-safe locking mechanism features a unique multi-tapered cam for superior performance that lasts.

ATI Tool Changers provide repeatable and reliable automatic tool changing under the rigors of industrial use. The unique No-Touch design simplifies robot teaching and minimizes wear and tear on the tool changer during payload pickup. The patented

Fail-Safe feature guarantees a secure connection of Master and Tool that withstands a loss of air pressure or significant moment loads.

The ATI Locking Mechanism features a pneumatic piston, a multi-tapered cam, and hardened steel locking balls. The following illustrations explain how the Locking Mechanism operates.

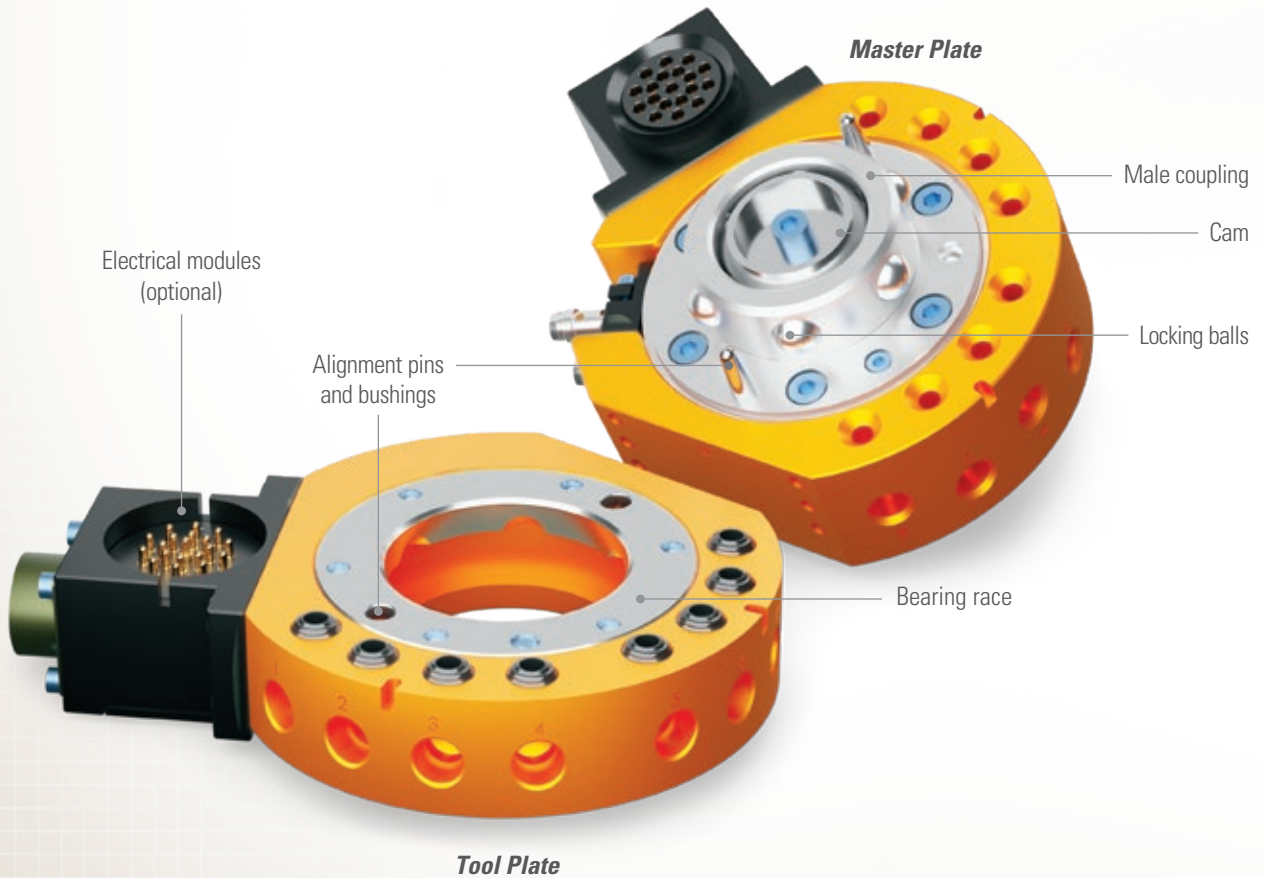

Pick-up (1st taper)

Hardened steel ball shown on the first taper of the cam. This taper allows for a slight separation of Master and Tool while locking.

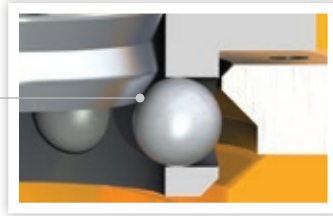

Close-up of locking mechanism components prior to locking

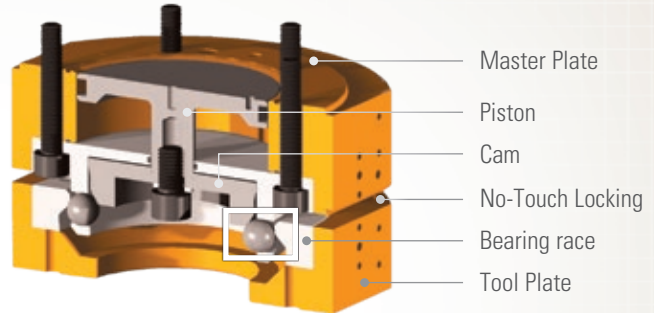

Section view of Tool Changer prior to locking

Locking (2nd taper)

Hardened steel ball moves to the second taper of the cam. This taper moves the locking balls outward as the piston drives the cam into place, creating extremely high locking forces.

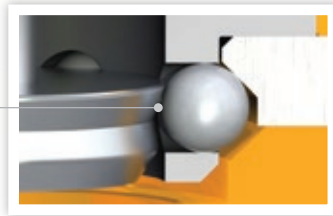

Close-up of locking ball in locked position

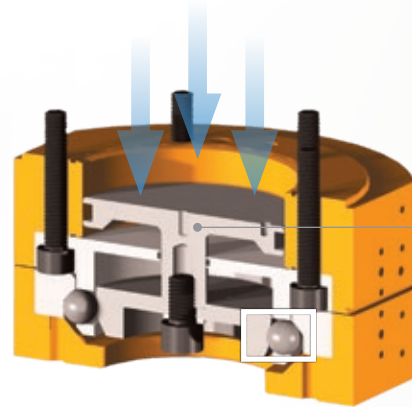

Section view of Tool Changer in locked position

Lock air pressure pushes the piston down, driving the balls out and under the bearing race, pulling the Tool plate up.

Fail-Safe (3rd taper)

Hardened steel ball rests on the Fail-Safe conical surface (reverse taper). In the event lock air pressure is removed, the locking balls are trapped by the cam, thus keeping Master and Tool plates attached securely. The Fail-Safe prevents the cam and piston from moving due to gravity, vibration, or acceleration.

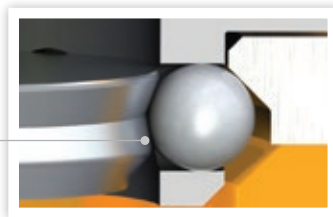

Close-up of locking ball while in Fail-Safe position

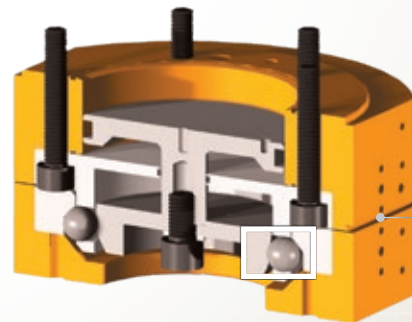

Section view of Tool Changer in Fail-Safe position

The Tool plate will not release from the Master plate unless unlock air pressure is applied.

ATI Robotic Tool Changers

ATI provides two distinct families of Tool Changers for robotic operations: Standard and Heavy Duty. Both feature similar locking mechanisms, but they have different body designs and payload abilities that suit different applications.

Standard Tool Changers

ATI Standard Robotic Tool Changers typically feature round bodies in a variety of sizes and payload capabilities. The style provides a compact tooling arrangement with an array of integrated pneumatic ports that often saves space for users. If additional electrical signals or other utilities need to be

passed through the tool changer, there are a wide range of add-on ATI Utility Modules that can be custom-configured. Additional accessories for Standard Tool Changers include sensors to indicate lock and unlock status, and highly customizable Tool Stand arrangements.



Standard Series Tool Changer QC-110

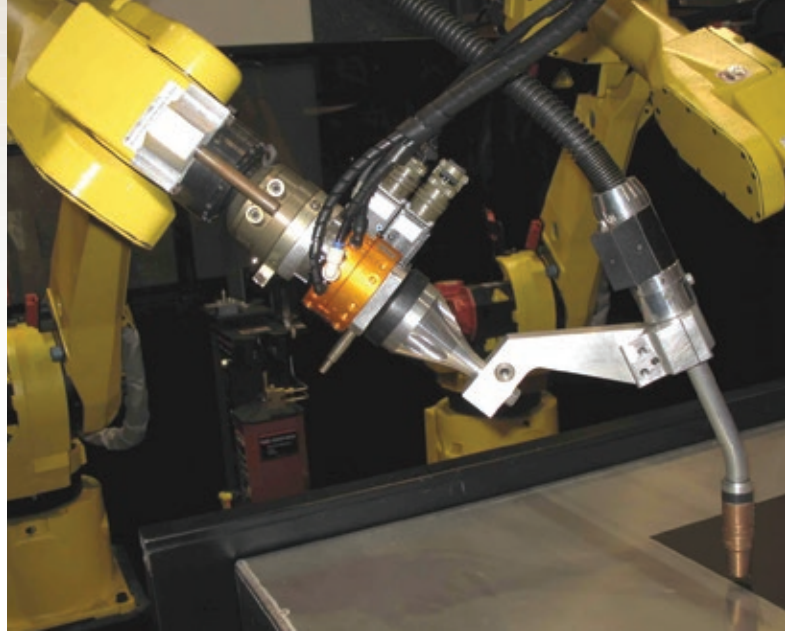

QC-20 Robotic Tool Changer utilized to exchange welding torches.

Specifications

MODEL	Suggested Payload Limit	Static Moment Capacity (X and Y)*	Static Moment Capacity (Z)*	Pneumatic Pass-Thru Ports (Qty) Size
QC-1	3 lb (1.4 kg)	8.7 lbf-in (0.983 Nm)	10.2 lbf-in (1.15 Nm)	(4) M5 or #10-32
QC-7	35 lb (16 kg)	180 lbf-in (20.3 Nm)	110 lbf-in (12.4 Nm)	(5) M5 or #10-32
QC-11	35 lb (16 kg)	180 lbf-in (20.3 Nm)	110 lbf-in (12.4 Nm)	(6) M5 or #10-32
QC-11 Hollow-Wrist	35 lb (16 kg)	180 lbf-in (20.3 Nm)	110 lbf-in (12.4 Nm)	See drawing
QC-20	55 lb (25 kg)	500 lbf-in (56.5 Nm)	690 lbf-in (78 Nm)	(12) M5 or #10-32
QC-20 Hollow-Wrist	55 lb (25 kg)	500 lbf-in (56.5 Nm)	690 lbf-in (78 Nm)	See drawing
QC-21	55 lb (25 kg)	500 lbf-in (56.5 Nm)	690 lbf-in (78 Nm)	(8) 1/8 NPT
QC-21 Hollow-Wrist	55 lb (25 kg)	500 lbf-in (56.5 Nm)	690 lbf-in (78 Nm)	See drawing
QC-22	55 lb (25 kg)	500 lbf-in (56.5 Nm)	800 lbf-in (90.4 Nm)	(6) 3/8 NPT
QC-40Q	110 lb (50 kg)	2000 lbf-in (226 Nm)	2000 lbf-in (226 Nm)	(8) 1/8 NPT
QC-41	110 lb (50 kg)	1390 lbf-in (157 Nm)	1910 lbf-in (216 Nm)	(6) 3/8 NPT; (4) 1/8 NPT
QC-46	110 lb (50 kg)	2000 lbf-in (226 Nm)	1330 lbf-in (150 Nm)	
QC-71	180 lb (79 kg)	3500 lbf-in (395 Nm)	3500 lbf-in (395 Nm)	(8) 1/4 NPT
QC-76	220 lb (100 kg)	4800 lbf-in (542 Nm)	6200 lbf-in (701 Nm)	(5) 3/8 NPT
QC-110	330 lb (150 kg)	6940 lbf-in (784 Nm)	6940 lbf-in (784 Nm)	(8) 3/8 NPT
QC-160	660 lb (300 kg)	24000 lbf-in (2710 Nm)	20000 lbf-in (2260 Nm)	(5) 3/8 NPT; (4) 1/2 NPT

* Dynamic ratings are higher than the published static ratings. Contact ATI for more information.

Heavy Duty Tool Changers

Heavy Duty Tool Changers are designed to handle both simple and complex applications such as material handling and welding and joining. The tool changer body is optimized to fit the largest, strongest locking mechanism possible. Each Heavy Duty Tool Changer features built in Lock/Unlock/Ready-to-Lock sensing for safe indication of tool changer status, as well as heavy-duty alignment pins for high repeatability. The Tool Changer body is designed

with a common Utility Module mounting pattern for flexible configuration and passage of multiple utilities such as pneumatics, fluid, electrical, fiber optic, weld current, and more. This unique series of heavy-duty Tool Changers is also compatible with a Tool Stand family that includes compliant drop-off points, Tool Shields, and a highly-customizable array of configurations.

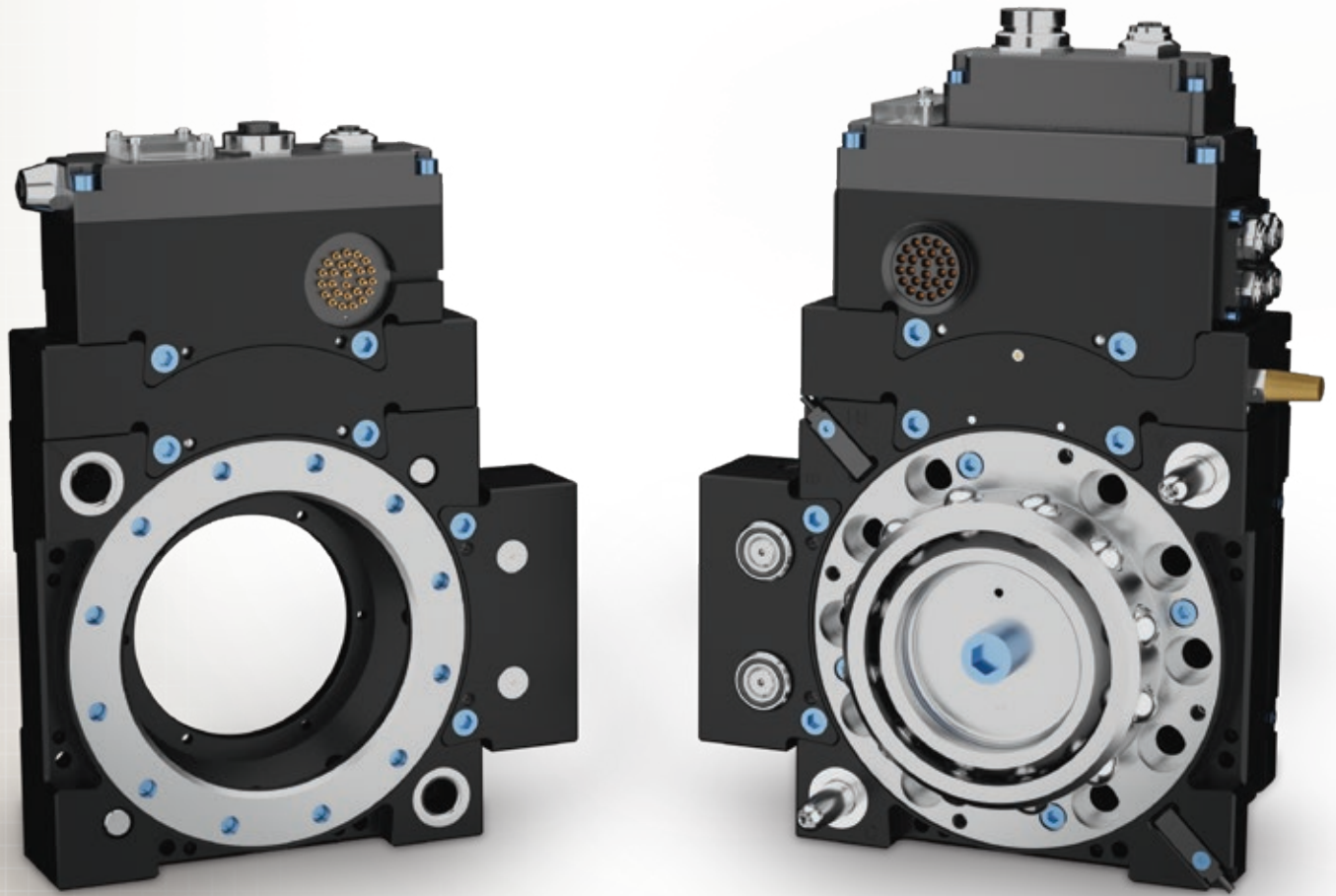

Heavy Duty Tool Changer QC-210 for material handling applications with integrated industrial Ethernet communications.

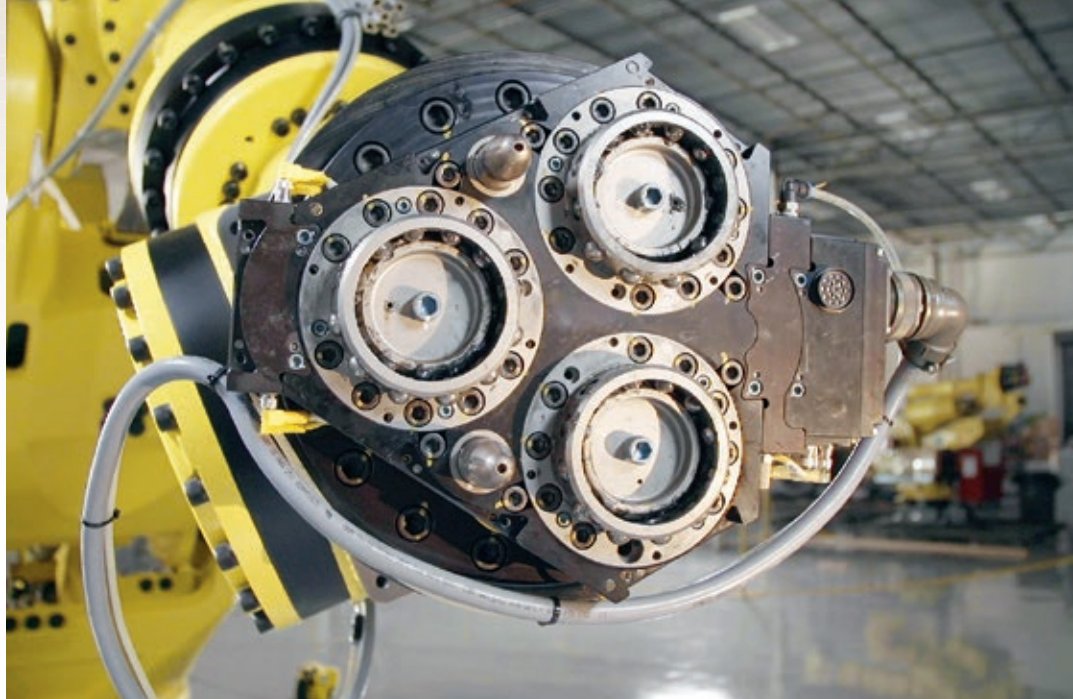

QC-1210 Heavy Duty Tool Changer

Specifications

MODEL	Suggested Payload Limit	Static Moment Capacity (X and Y)*	Static Moment Capacity (Z)*
QC-210	660 lb (300 kg)	24000 lbf-in (2710 Nm)	20000 lbf-in (2260 Nm)
QC-310	1100 lb (510 kg)	29100 lbf-in (3290 Nm)	28000 lbf-in (3290 Nm)
QC-510	1500 lb (700 kg)	43000 lbf-in (4860 Nm)	31000 lbf-in (3500 Nm)
QC-1210	2980 lb (1350 kg)	48000 lbf-in (5420 Nm)	48000 lbf-in (5420 Nm)
QC-1310	6600 lb (2990 kg)	97500 lbf-in (11000 Nm)	111000 lbf-in (12600 Nm)
QC-1510	9000 lb (4080 kg)	144000 lbf-in (16300 Nm)	123000 lbf-in (13900 Nm)

* Dynamic ratings are higher than the published static ratings. Contact ATI for more information.

Tool Changer Utility Modules

ATI Tool Changers are designed for flexibility and thrive in a wide variety of application environments. While ATI offers many different Tool Changer models, it is our vast array of compatible Utility Module offerings that unlock their versatility. ATI's Utility Modules attach directly to the Master and Tool plates and allow users to pass utilities such as electrical, pneumatic, fluid, control signals, servo, high-current and others through the tool changer to the end-of-arm tooling. The ability to integrate utilities into their robotic applications through the Tool Changer provides flexibility and freedom to configure the cable routing system in an optimal manner.

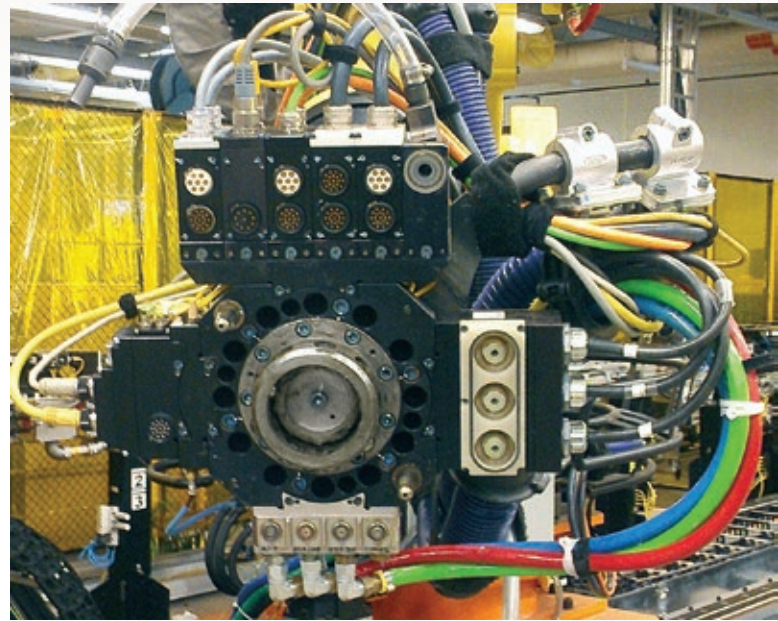

ATI Utility Modules mount directly to the tool changer body and allow the integration of a variety of utilities to the end-of-arm tooling.

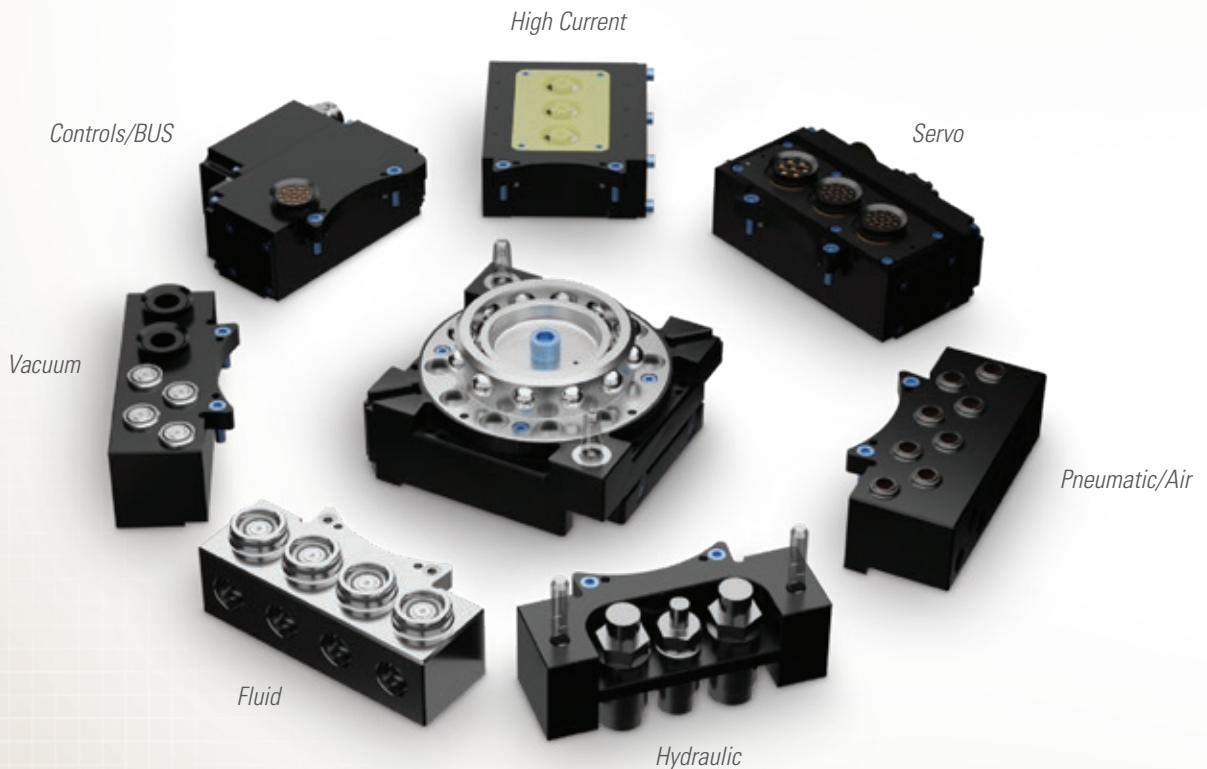

Tool Stands

ATI's Tool Changer product family includes a collection of Tool Stands that provide efficient storage for end-of-arm tooling with easy access to the robot. With ATI's Tool Stands, users have access to a modular system of tool storage options that can be configured to suit almost any application. Available in a variety of small, medium, and large sizes, ATI Tool Stands provide users a modular system of tool storage options that can be configured to suit almost any application.

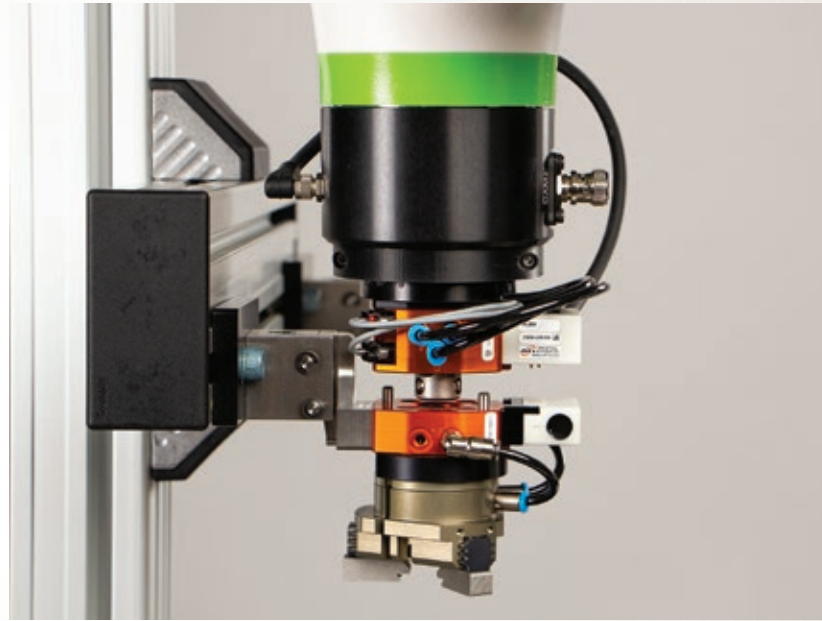

ATI Tool Stand systems can be configured for almost any type of application.

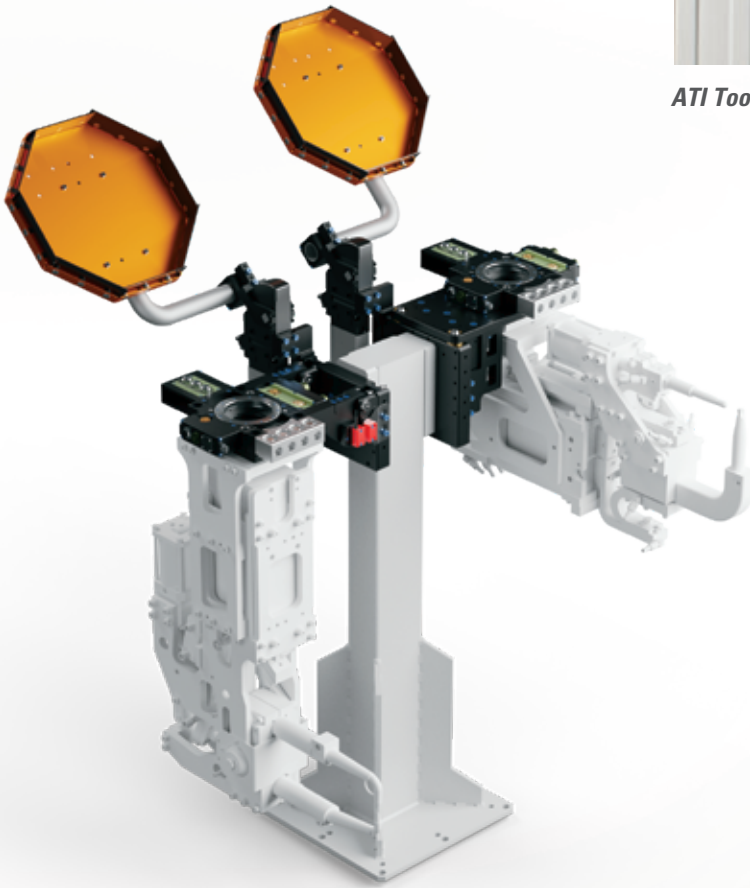

Tool Stand Large (TSL) Configuration Example



Tool Stand Small (TSS) Configuration Example

Choose the right ATI Tool Changer for your application

ATI Tool Changer models are differentiated by their payload and moment capacity. Payload capability refers to the amount of static weight a tool changer can handle and is often relative to the robot's rated payload. Moment capacity is the critical factor in determining the appropriate tool changer size and refers to the loading that occurs as the robot articulates dynamically through the process. For help choosing the right ATI Tool Changer, please visit www.ati-ia.com/ToolChangerSizing.

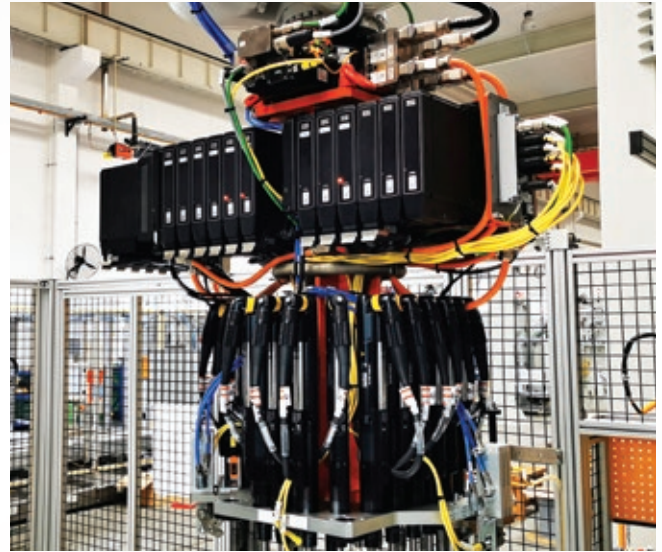

ATI QC-210 Heavy Duty Tool Changer utilized in complex nutrunner system.

Tool Changer Accessories offer even more value

Sensor Interface Plate (SIP)

Sensor Interface Plates (SIP) attach to the Master plate and feature integrated sensing to detect when the locking mechanism is in locked or unlocked positions, in order to provide input signals to the process controller.

Interface Plate (IP)

Interface Plates (IP) enable adaptation of the Robotic Tool Changer mounting patterns to various robot mounting patterns, or customer-specified patterns.

Dust Covers

In some application environments, it is advantageous to protect robot tooling when it's not in use. ATI offers Dust Covers that shield the mating face of the Tool plate and attached modules from debris.

Connector Mates and Cables

ATI offers a wide variety of standard options for connecting our electrical Utility Modules. Upon request, ATI can provide commercial mating cable assemblies and connector mates for customer-supplied cables.

Teaching Aids

ATI Teaching Aids help teach the robot to pick-up and drop-off the tool faster and reduce unnecessary wear resulting from improper alignment of the Tool and Master.

ATI can design a custom solution just for you

ATI Tool Changers are designed to increase flexibility and productivity in automated systems across a wide variety of industries. As these applications expand into new markets, ATI continues to pioneer new tool changing solutions for our diverse customers. With a vast team of mechanical, electrical, and software engineers ATI has developed specialized products for extreme applications ranging from metal casting foundries, to operation in clean room

environments for robotic surgery, to robotic systems in outer space. ATI partners with our customers to drive innovation forward. Whether it's a modification of an existing product or a completely new design, our engineering team is here to support your automation journey. For more information about custom tool changing solutions, contact ATI's Applications Team.



Custom Tool Changer developed for automated box opening system.

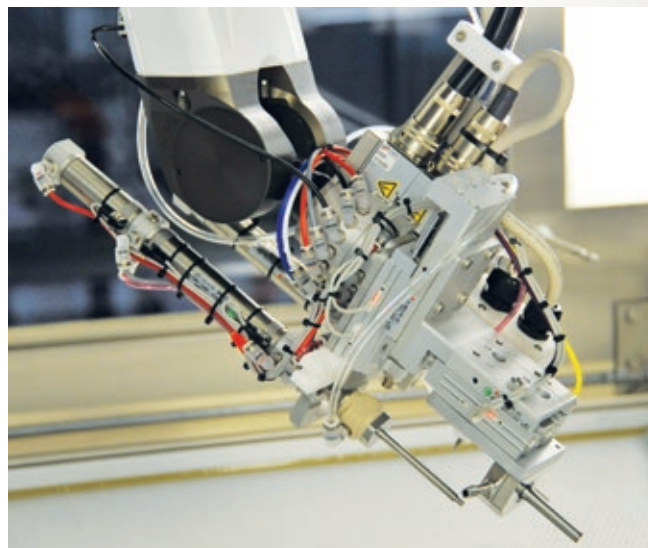

Custom Tool Changer utilized in sterile pharmaceutical laboratory.

Product and maintenance training services

ATI products are designed to last, and our goal is to empower our customers to take ownership of their automated solutions. ATI offers a comprehensive menu of product and application support services focused on optimizing the value of your ATI equipment. Reduce downtime, increase efficiency, and maximize the life of your ATI solution with personalized education and training packages.

Options for training include a broad range of product overview and support resources as well as plant floor services such as installation review, product health checks, preventative maintenance plans, and system debug. Whatever the application, ATI has the right product and the support services required to help your application thrive.



Force/Torque Sensors Automate complex tasks and measure with accuracy.

Product Description

For over 30 years, ATI has manufactured the highest performing Force/Torque Sensors. Our broad range of transducer sizes and electronic interfaces integrate seamlessly into any application. When used with robots, force sensing empowers precise applications such as product testing, process verification, industrial assembly, and other nuanced operations. The data output from the F/T Sensor can be collected for analysis, monitored, or used to control a process or task.

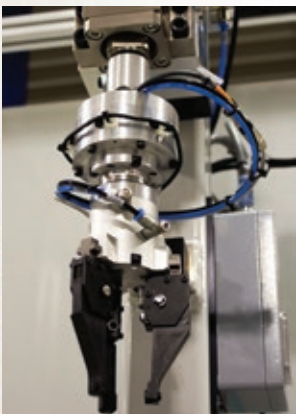

ATI F/T Sensors deliver the highest resolution and accuracy available and provide a comprehensive load profile across all axes of force and torque

(X, Y, Z). This is helpful for users who want to better understand the loads generated in a process. In other applications, like robotic circuit board assembly, data is captured in real-time to give users dynamic control of the process. Our proprietary instrumentation and calibration process creates a very accurate sensor by reducing cross talk between axes and minimizing hysteresis and non-linearity. Our F/T sensors provide extremely reliable data and allow users to precisely control robot movements to automate challenging tasks.

All ATI F/T Sensors are engineered for long lasting performance and high accuracy. Each sensor is calibrated and tested throughout its entire usable range and comes with a traceable calibration certificate ensuring it will perform to our exact specifications.

Force/Torque Sensor Applications

Force/Torque Sensor applications vary greatly, but can be loosely categorized in the following ways:

Industrial automation and manufacturing applications where the sensor data will be consumed as an input to programming. Examples include welding or grinding, assembly, end-of-line testing, or other applications taking place in a factory or manufacturing setting.



ATI F/T Sensor utilized in precision electronic assembly.

Research and development applications that require very accurate and precise data. Examples include accurate, high-resolution, high-speed, data logging applications conducted in labs and research facilities.

Custom force sensing applications utilize custom components deployed in extreme environments. Examples include custom-engineered force sensing systems for outer space, surgical robot, or radioactive applications.



ATI F/T Sensor used in automotive seat testing.

Interface Structure—high-strength alloy provides IP60, IP65, and IP68 environmental protection as needed

Sensing Beams and Flexures—designed for high stiffness and overload protection without compromising resolution

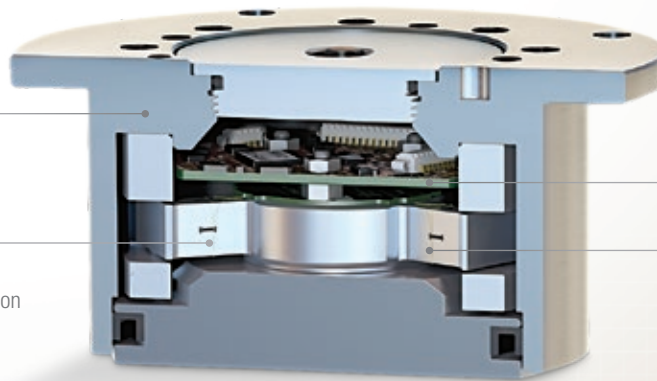

High-Speed Electronics—interfaces for Ethernet, PROFINET, EtherNet/IP, Analog, USB, CAN EtherCAT, Wireless, and more

Silicon Strain Gages—standard on all F/T models, provide high noise immunity, accuracy, and high factor-of-safety

Choose the right F/T Sensor for your application

ATI's Force/Torque Sensor systems include a pre-calibrated transducer that is mounted to a robot or fixture, shielded cabling, and interface electronics. Defining the application type, desired resolution and accuracy, and moment capacity is instrumental in selecting an F/T Sensor model and choosing the interface electronics.

The measurement range must account for the combined static and dynamic forces that are applied to the sensor, and includes not only the weight of the end-effector, but also the forces generated as the robot arm and tooling move through the opera-

tion. ATI F/T Sensors feature overload protection to account for unexpected forces beyond the measurement range.

Resolution is the smallest load change that can be detected by a Force/Torque Sensor System. Each sensor's calibration options and electronics package determine the system resolution.

ATI offers a wide variety of standard Force/Torque models and configuration options. For help choosing the correct F/T sensor for your process, visit our website at www.ati-ia.com/FTSizingGuide or reach out to our knowledgeable applications staff.

ATI F/T Sensor utilized in biomechanical research. Image courtesy of Cleveland Clinic BioRobotics Lab.

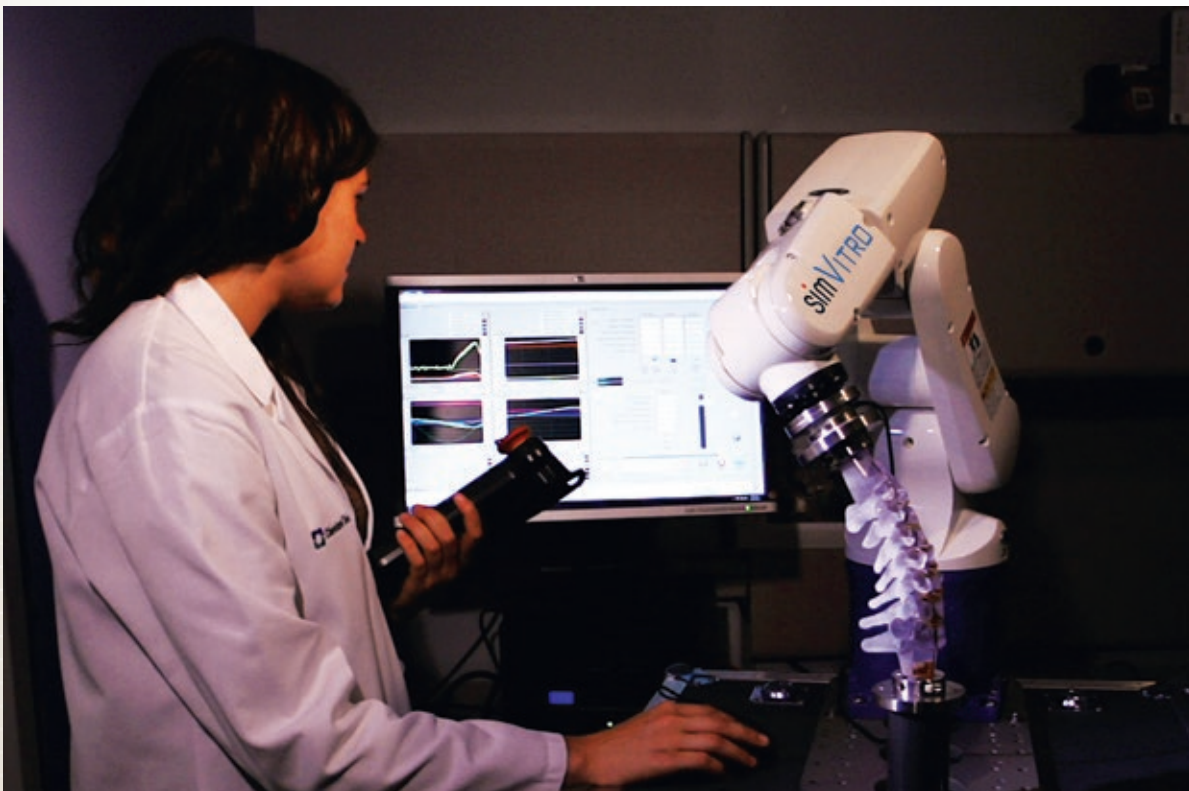

Specifications

MODEL	Measurement Range Fx,Fy	Measurement Range Fz	Measurement Range Tx,Ty,Tz	Minimum Force Resolution Fx,Fy,Fz	Minimum Torque Resolution Tx, Ty, Tz	Diameter*	Height*
Axia80-M8	±150 N	±470 N	±8 Nm	0.0400 N	0.0020 Nm	82 mm	25.4 mm
Axia80-M20	±500 N	±900 N	±20 Nm	0.1000 N	0.0050 Nm	82 mm	25.4 mm
Axia80-M50	±1200 N	±2000 N	±50 Nm	0.5000 N	0.0161 Nm	82 mm	25.4 mm
Nano17 Titanium	±32 N	±56.4 N	±200 Nmm	0.0015 N	0.0069 Nmm	17 mm	14.5 mm
Nano17	±50 N	±70 N	±500 Nmm	0.0031 N	0.0156 Nmm	17 mm	14.5 mm
Nano25	±250 N	±1000 N	±6 Nm	0.0208 N	0.0004 Nm	25 mm	21.6 mm
Nano43	±36 N	±36 N	±500 Nmm	0.0020 N	0.0250 Nmm	43 mm	11.5 mm
Mini27 Titanium	±80 N	±160 N	±4 Nm*	0.0150 N	0.0003 Nm	27 mm	18.2 mm
Mini40	±80 N	±240 N	±4 Nm	0.0050 N	0.0001 Nm	40 mm	12.2 mm
Mini45 Titanium	±240 N	±480 N	±12 Nm	0.0167 N	0.0003 Nm	45 mm	17.5 mm
Mini45	±580 N	±1160 N	±20 Nm	0.0625 N	0.0007 Nm	45 mm	15.7 mm
Mini58	±2800 N	±6800 N	±120 Nm	0.1667 N	0.0031 Nm	58 mm	30 mm
Mini85	±1900 N	±3800 N	±80 Nm	0.0804 N	0.0023 Nm	85.1 mm	29.8 mm
Gamma	±130 N	±400 N	±10 Nm	0.0063 N	0.0005 Nm	75.4 mm	33.3 mm
Delta	±660 N	±1980 N	±60 Nm	0.0313 N	0.0019 Nm	94.5 mm	33.3 mm
Theta	±2500 N	±6250 N	±400 Nm	0.2500 N	0.0125 Nm	155 mm	61.1 mm
Omega85	±1900 N	±3800 N	±80 Nm	0.0714 N	0.0023 Nm	85.1 mm	33.4 mm
Omega160	±2500 N	±6250 N	±400 Nm	0.2500 N	0.0125 Nm	157 mm	55.9 mm
Omega191	±7200 N	±18000 N	±1400 Nm	0.3750 N	0.0347 Nm	190 mm	64 mm
Omega250 IP60	±16000 N	±32000 N	±2000 Nm	1.0000 N	0.1250 Nm	295 mm	94.9 mm
Omega331	±40 kN	±88 kN	±6 kNm	0.0016 kN	0.0002 kNm	330 mm	107 mm

*Tz Range is 2Nm

Configuration Options

The mechanical interface determines how the F/T Sensor is mounted. Included in each Force/Torque Sensor system is an interface plate that will be used to mount the transducer to a robot or fixture. Select from a variety of bolt patterns, or choose a blank interface plate to machine a custom pattern.

ATI's Force/Torque sensors can be customized for special environments or include multiple calibrations. Most models are available with IP-60, -65, and -68 Ingress Protection ratings to safeguard against dusty applications like wood finishing, or wet environments such as polishing or underwater research.

Multiple calibrations enable users to pinpoint varied resolution requirements with the same sensor. Pairing a close-range high resolution with a longer range coarse resolution allows the robot to perform operations in different load ranges while ensuring the highest resolution data is being used.

The electronic interface is determined by the application parameters. ATI offers a wide array of interface options to allow users to integrate their F/T Sensor to any type of system. Beyond ATI's selection of standard interface electronics, specially-engineered electronic interfaces are available as well.

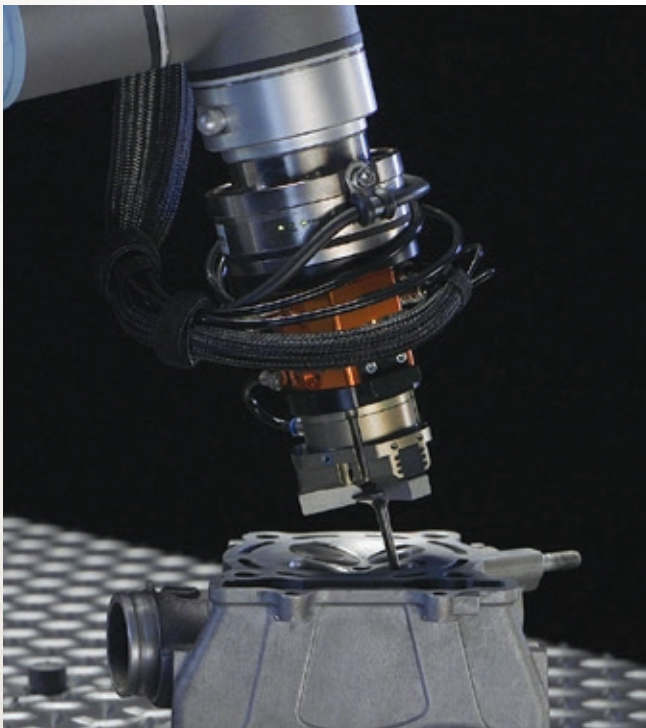

ATI F/T Sensor utilized in robotic valve insertion.

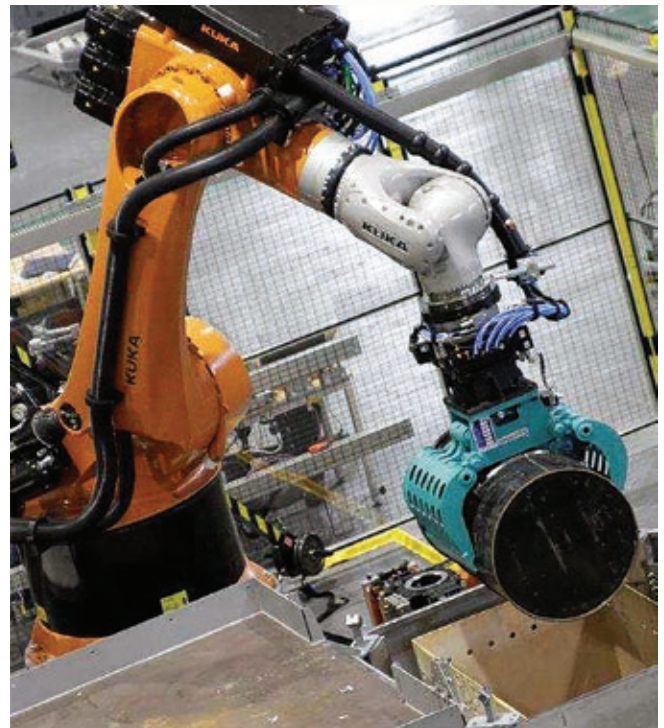

ATI F/T Sensor used in nuclear decommissioning.

Custom Force/Torque Sensing Solutions

The engineering team at ATI has developed a variety of custom designed Force/Torque sensors to suit unique application situations such as remote explo-

ration of Mars and surgical robotics. Visit www.ati-ia.com/CustomFT for more information about our Custom Force/Torque Sensor capabilities.



ATI Space-Rated F/T Sensor.



Mars 2020 Perseverance Rover.



Material Removal Tools **Compliant, robust, and reliable.**

Product Description

ATI's Material Removal Tools feature integrated compliance that enables consistent and repeatable processing that is quick and easy to program. These tools excel in a vast array of material removal tasks such as deburring, deflashing, edge-breaking, surface finishing, and more. Users can attach the end-effectors to a robot wrist for process-to-part operations, or mount to a bench or fixture for part-to-process setups. Many Material Removal Tools utilize



durable pneumatic- or electrical- powered motors and offer speed options and compliance ranges that suit a wide range of operations.



ATI RC-300 Deburring Tool utilized in automotive wheel deburring.

Multiple Product Categories to Suit Specific Applications

Compliant Deburring Blade

The Compliant Deburring Blade is the solution for automating hand-deburring tasks. Ideal for robotic and non-robotic applications, the motorless CDB is compatible with the same cutting media used in hand-tools and can be used on a variety of materials. It also includes an option for automatic blade changing.



Specifications

MODEL	Weight	Radial Compliance	Axial Compliance	Radial Compliance Force	Axial Compliance Force
CDB-8-11	2.4 lb (1.09 kg)	±5.5°	0.32 in (8 mm)	5.7 lbf - 17 lbf (25 N - 76 N)	3 lbf - 15 lbf (13 N - 67 N)
CDB-8-11-ATC	2.4 lb (1.09 kg)	±5.5°	0.32 in (8 mm)	5.7 lbf - 17 lbf (25 N - 76 N)	3 lbf - 15 lbf (13 N - 67 N)

Compliant Reciprocating Tools

Compliant Reciprocating Tools feature a unique filing motion that is uniquely suited for removing burrs from corners and deep grooves. With adjustable cutting force, users can adapt their process to achieve a myriad of part finishes.



Specifications

MODEL	Stroke	Weight	Compliance Travel at Collet	Compliance Force	Idle Speed
CRT-12-5	0.2 in (5 mm)	6.8 lb (3.08 kg)	0.32 in (8.1 mm)	3 lbf - 20 lbf (13 N - 89 N)	12000 Strokes Per Minute (SPM)

Axially-Compliant Finishing Tools

Axially-Compliant Finishing Tools are robust, high-torque, air tools featuring axially-floating motion ideal for sanding and finishing. This design enables a light touch on the work piece and suits a variety of robotic and non-robotic applications on aluminum, composites, wood, steel, and other materials.



Specifications

MODEL	Weight	Compensation	Compliance Force*	IdleSpeed
AOV-10	5.65 lb (2.56 kg)	0.5 in max. axial, ±0.2 in recommended (13 mm max. axial, ±5.1 mm recommended)	1.5 lb - 15 lb (6.7 N - 67 N)	10000 rpm
ACT-390	7.25 lb (3.29 kg)	0.59 in max. axial, ±0.3 in recommended (15 mm max. axial, ±7.6 mm recommended)	3.2 lb - 17 lb (14 N - 74 N)	5600 rpm

*Pneumatically Variable

Force Control Devices

ATI's Force Control Devices are standalone units used to integrate compliance into a process. ATI's Passive Compliant Force Control (PCFC) device creates more responsiveness for automated processes that utilize customer-supplied rigid end-effectors such as bench grinding, die grinding, cutting, and gate removal.

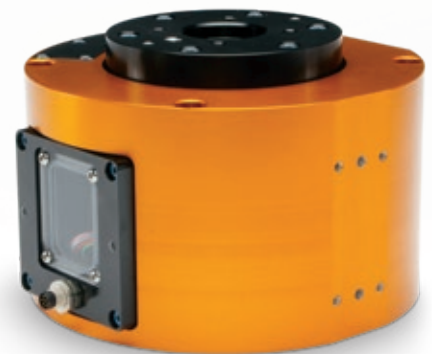

Specifications

MODEL	Weight	Compliance Travel	Compliance Force Range
PCFC-12-A-S1	7.8 lb (3.54 kg)	0.47 in (12 mm)	4 lbf - 19 lbf (18 N - 85 N)
PCFC-12-B-S1	7.9 lb (3.58 kg)	0.47 in (12 mm)	10 lbf - 39 lbf (44 N - 170 N)
PCFC-12-C-S1	8.0 lb (3.63 kg)	0.47 in (12 mm)	11 lbf - 54 lbf (49 N - 240 N)

Radially-Compliant Deburring Tools

Radially-Compliant Deburring Tools feature an articulated design that compensates for surface irregularities, part location variation, and robot misalignment. They are perfect for flash removal from parting lines, deburring edges, and more on a variety of materials.



Specifications

MODEL	Power	Weight	Compliance Travel at Collet	Compliance Force*	IdleSpeed
RC-151	150 W (0.2 hp)	2.4 lb (1.09 kg)	0.2 in (5.1 mm)	0.7 lbf - 1.5 lbf (3.1 N - 6.7 N)	65000 rpm
RC-300	300 W (0.4 hp)	2.5 lb (1.13 kg)	0.3 in (7.6 mm)	2.8 lbf - 9.5 lbf (12 N - 42 N)	30000 rpm
RC-340	340 W (0.46 hp)	2.5 lb (1.13 kg)	0.3 in (7.6 mm)	2.8 lbf - 9.5 lbf (12 N - 42 N)	40000 rpm
RCV-390	390 W (0.52 hp)	9.75 lb (4.42 kg)	0.28 in (7.1 mm)	2 lbf - 16 lbf (8.9 N - 70 N)	5600 rpm
RCV-490	490 W (0.66 hp)	7.4 lb (3.36 kg)	0.32 in (8.3 mm)	1.5 lbf - 12 lbf (6.7 N - 53 N)	30000 rpm
RS-660-ER	660 W (0.88 hp)	5.5 lb (2.49 kg)	0.26 in (6.6 mm)	4.1 lbf - 17 lbf** (18 N - 74 N**)	40000 rpm
RC-900	900 W (1.2 hp)	7.6 lb (3.45 kg)	0.35 in (8.9 mm)	6.5 lbf - 20 lbf (29 N - 87 N)	25000 rpm
RC-1040	1000 W (1.4 hp)	7.6 lb (3.45 kg)	0.35 in (8.9 mm)	6.5 lbf - 20 lbf (29 N - 87 N)	40000 rpm

*Pneumatically Variable **Compliant in one axis only

Radially-Compliant Electric Deburring Tools

Featuring the same built-in compliance as our other material removal tools, Radially-Compliant Electric Material Removal Tools are electrically-powered with large bearings and a shaft designed for demanding robotic use, plus a variable speed motor with a range of 0 to 13,000 rpm. These tools are ready for a diverse array of robotic material removal tasks such as rust and weld spatter removal, blending, polishing, and light grinding.



Specifications

MODEL	Power	Weight	Compliance Travel at Collet	Compliance Force*	IdleSpeed
RCE-710	710 W (0.95 hp)	11.8 lb (5.35 kg)	0.2 in (5.1 mm)	2.5 lbf - 18 lbf (11 N - 80 N)	0 - 13,000 rpm



Axially-Compliant Deburring Tools

Axially-Compliant Deburring Tools are engineered for robotic use and feature an axially-floating rotary cutting burr. Their lightweight, robust, high-speed, design is great for edge-deburring and chamfering of aluminum, plastic, steel, and other materials.

Specifications

MODEL	Weight	Max Burr Comp.	Axial Force Range
AC-90	1.12 lb (0.508 kg)	0.16 in (4.1 mm)	1.9 lb - 7.4 lb (8.5 N - 33 N)
AC-180	1.12 lb (0.508 kg)	0.16 in (4.1 mm)	1.9 lb - 7.4 lb (8.5 N - 33 N)

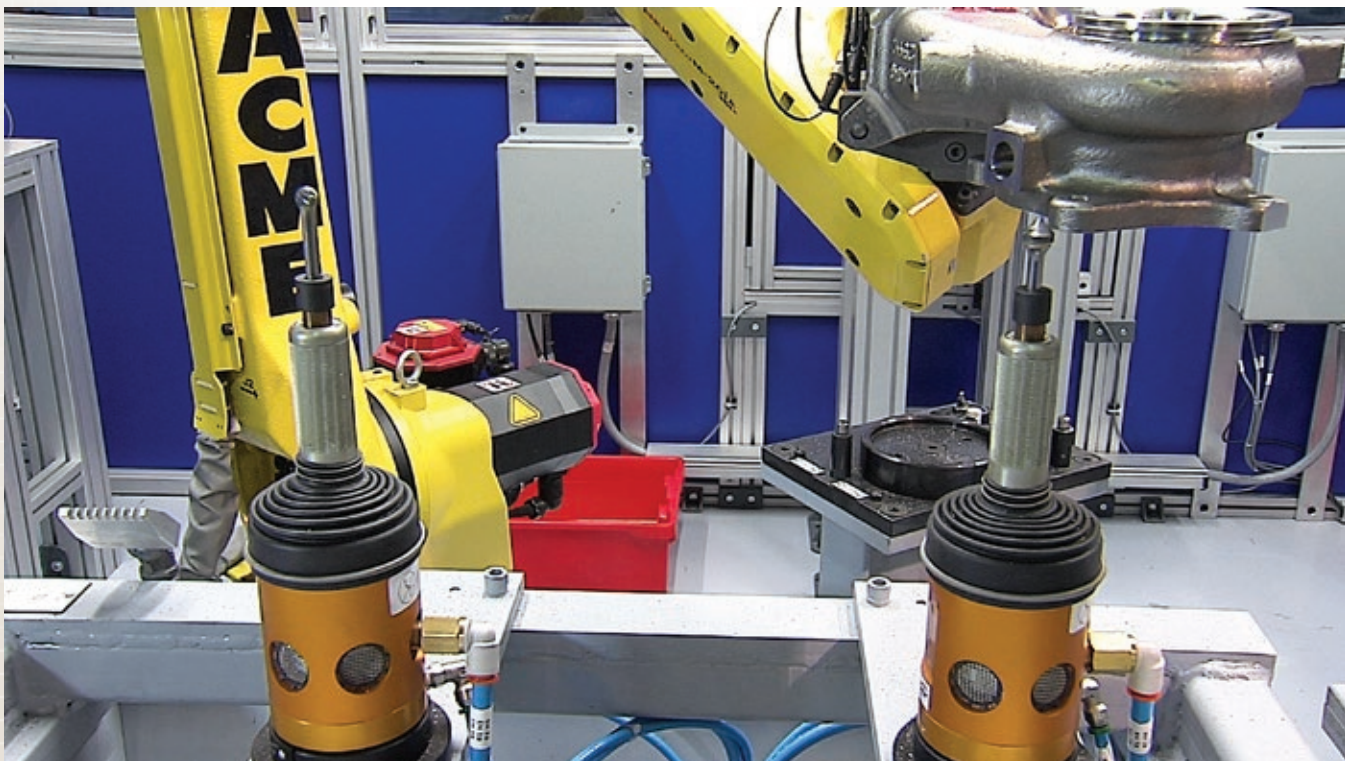

ACME Manufacturing optimizes efficiency of deburring large heavy components by using the robot to bring the part to multiple ATI RC-340 Deburring Tools. Compliant Deburring Tools with an array of cutting bits allow the cell to deburr various part features in one cycle.

Material Removal Testing Services

New to automated material removal? ATI offers in-house Material Removal Testing Services to match users with their ideal material removal solution. The Material Removal Testing program offers high levels of flexibility and customization for users of any experience level. ATI Material Removal experts work closely with your team to determine testing objectives, potential solutions, process constraints and requirements. ATI then selects the appropriate testing methods and deliverables to verify the cus-

tomers' process. At the conclusion of the trials, users receive specific product recommendations, detailed reports of the testing results, as well as guidance for integrating the solution. ATI's Material Removal Testing Services give users confidence in their new system and help jump-start the implementation process.

For more information about ATI's Material Removal Testing Services, visit www.ati-ia.com/MRTTest.

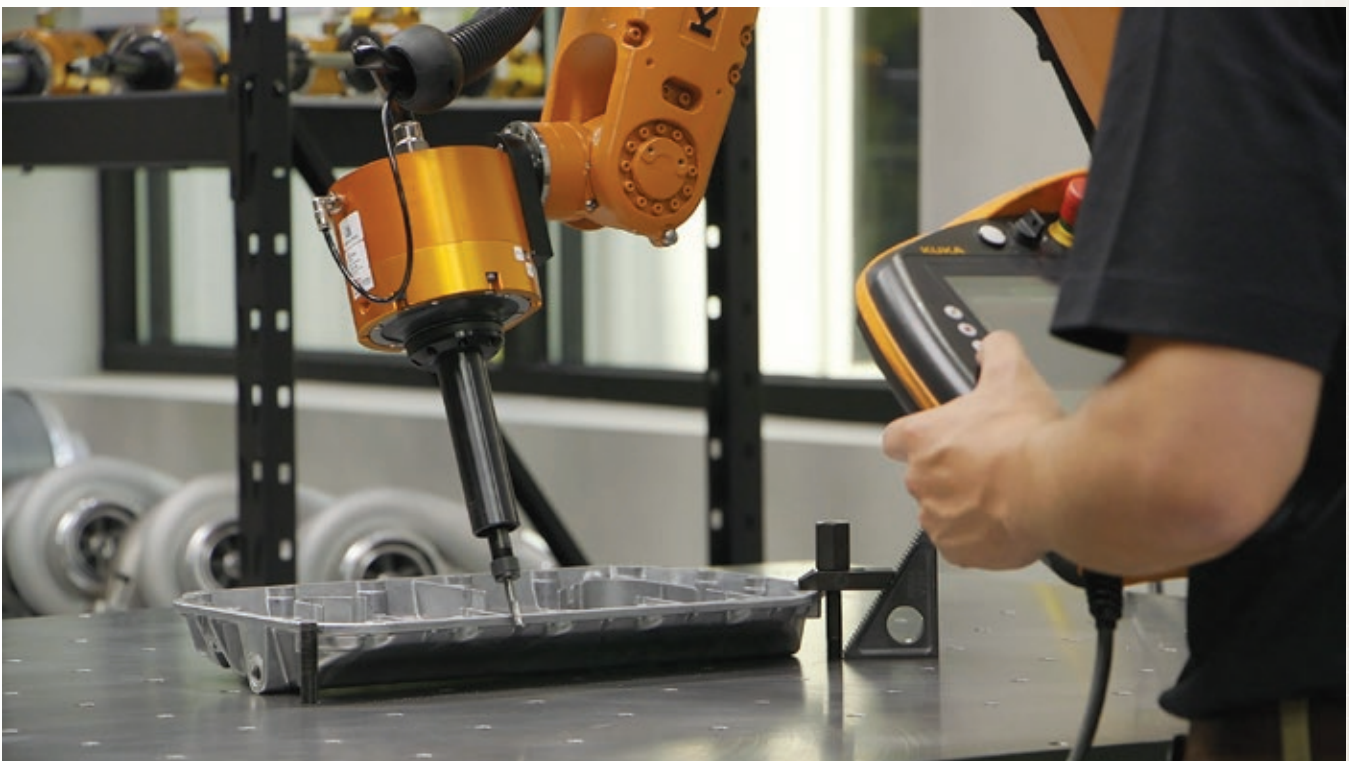

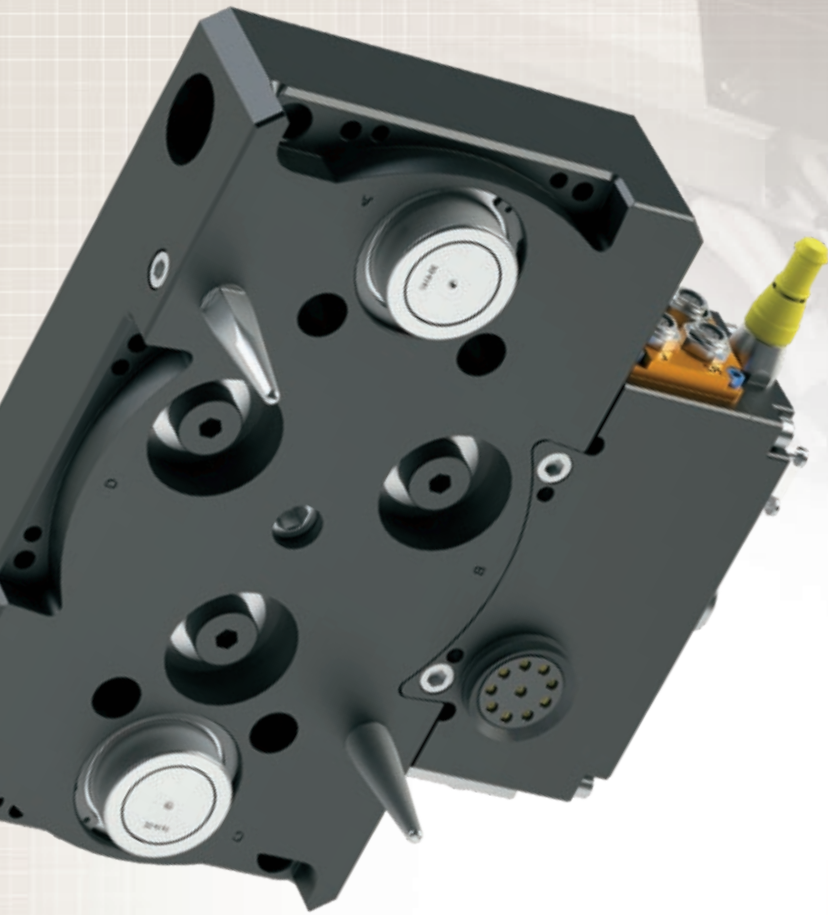

Utility Couplers

Quickly connect utilities in docking and fixturing applications.

Product Description

ATI Utility Couplers are utilized to quickly connect utilities such as air, fluid, power and electrical signals



in docking and fixturing applications. The modular, multi-coupling design can attach any of ATI's Utility Modules and will improve cycle time and flexibility in any production cell. The Master-side connection features a unique compliance mechanism that allows for large tooling misalignments. Utility Couplers can be provided with an

air actuated drive cylinder or locking mechanism to secure the two halves of the Utility Coupler together. ATI Utility Couplers offer a quick and cost-effective solution to your challenging coupling needs.

Product Highlights

Built-in engineered compliance ensures reliable coupling.

Common mounting flats attach ATI Utility Modules.

Integrated pneumatic ports available.

Compatible Fieldbus network includes DeviceNet, Ethernet, PROFINET, and more.

Drive Cylinders and Locking Mechanisms available.

Tool-side presence sensors available.

Utility Couplers typically feature an anodized aluminum body, a hardened stainless steel alignment pin system, and hardened-steel overload pins.

The device depends on force from an optional drive cylinder or locking mechanism to maintain constant coupling pressure. ATI Utility Couplers can also be coupled manually by a patented locking steel latch that draws in the utility connections. It is important to correctly size the correct drive cylinder for your application. Considerations must be made to account for the counteracting forces from the integrated pneumatic ports when sizing your drive cylinder. The Utility Coupler models page shows compatible drive cylinder assemblies for each Coupler style.

Unique Compliance Mechanism

Utility Couplers have a unique compliance feature built into the Master-side that allows for compliance in any direction in the coupling plane. There are preloaded springs internal to the housing that force the main body to self-center on custom chamfered thrust bearings. Our Utility Couplers are strong, secure devices that can overcome relatively large misalignment of the Master and Tool.

ATI Utility Couplers can also be rigid. The rigid couplers offer a low-cost solution for connecting pneumatic or electric utilities and are well-suited for applications where the corresponding fixtures can be well aligned.

Modular Body Design—capable of mounting any of ATI's standard utility modules

Unique Compliance Mechanism—allows for large tooling misalignments

Integrated Utilities—a wide variety of models include integrated pneumatic and fluid ports



Add-on Utility Modules

ATI Utility Couplers are ideal for a wide variety of applications due to their compatibility with ATI's extensive collection of Utility Modules. The Master and Tool bodies are equipped with module mounting features that enable the coupler to connect multiple Utility Modules in a variety of configurations.

ATI's vast selection of Utility Modules provides flexibility in applications by enabling the connection of a variety of utilities such as electrical, pneumatic, fluid, control signals, servo, high-current, and more.

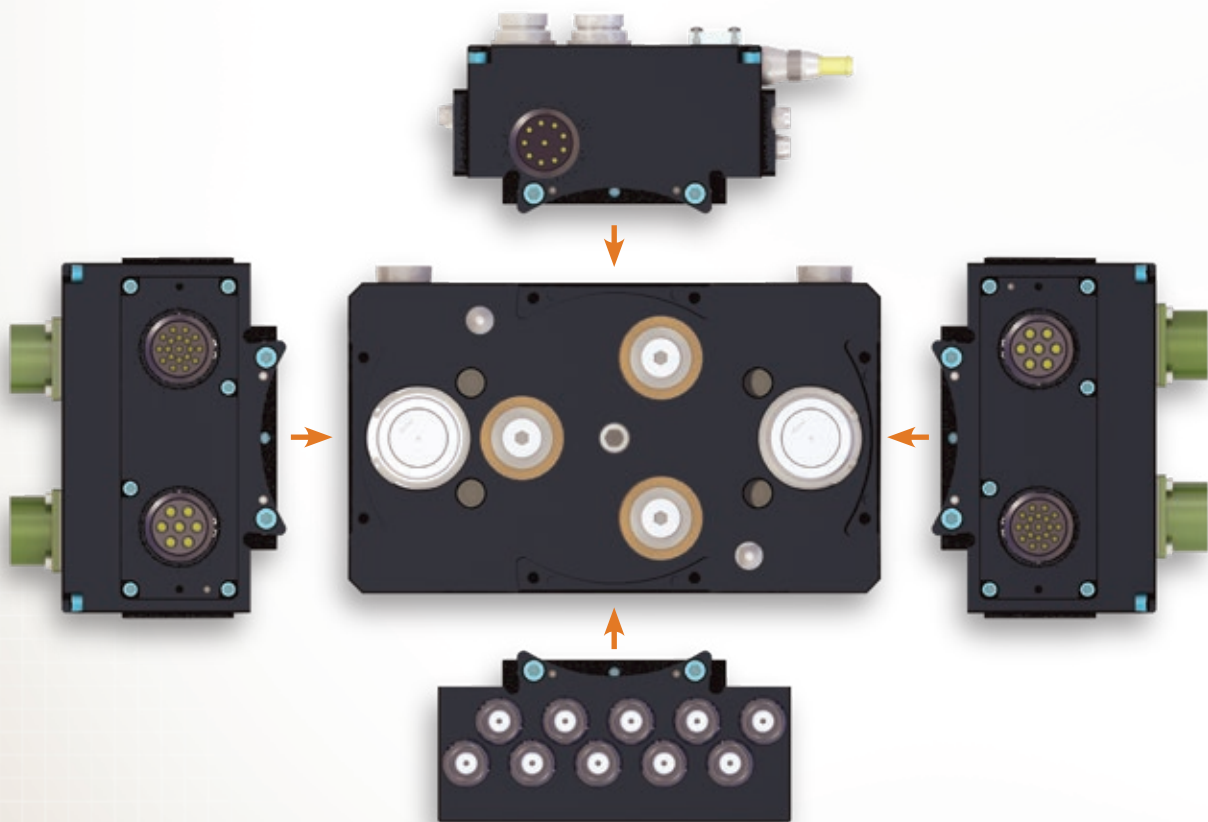

Utility Coupler module-to-body connection (Model GL2).

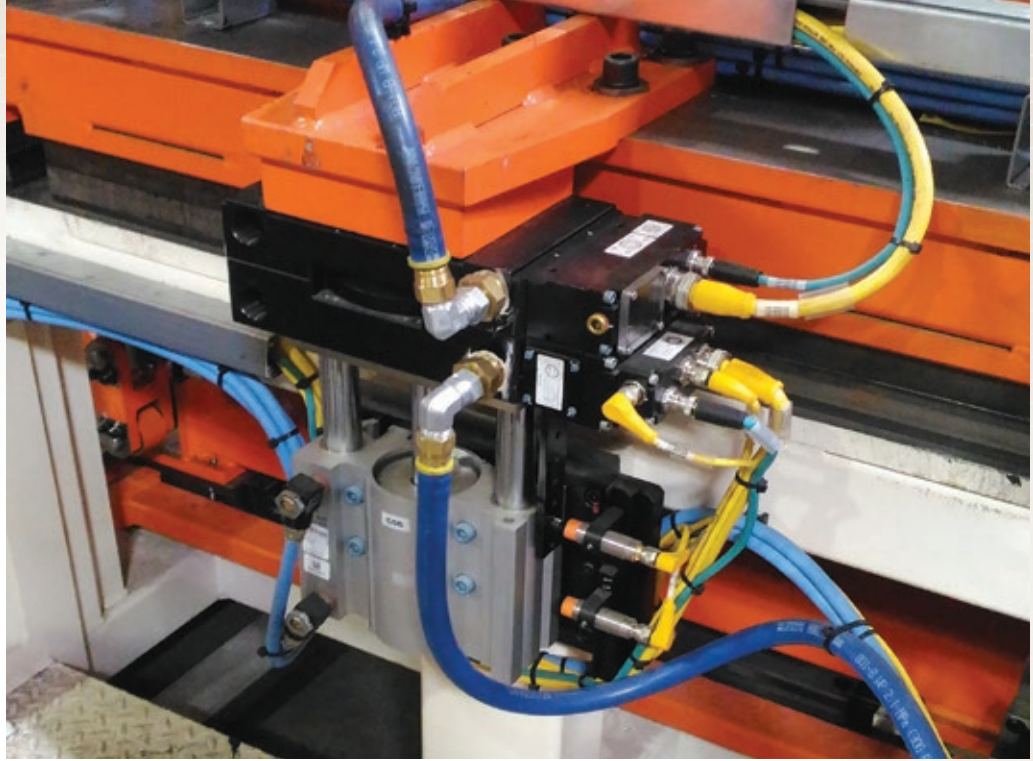

ATI Utility Coupler provides power and signal connection to a rotary hemming table.

Specifications

MODEL	Compliance Type	Compliance X-Y	Locking Type	Min. Couple Force*	Port #	Port Size	Port Type	Module Type	# Flats
UC-GA1	Integrated	±0.059 in	None	N/A	0	N/A	N/A	Light	N/A
UC-GA2	None	N/A	None	320 lbf	10	3/8	Pass Thru	Medium	2
UC-GH1	None	N/A	Manual	N/A	4	3/8	Checked	Medium	3
UC-GH2	None	N/A	Manual	N/A	16	M6	Pass Thru	Medium	N/A
UC-GH3	None	N/A	Manual	N/A	8	M6	Pass Thru	N/A	N/A
UC-GH5	None	N/A	Manual	N/A	0	N/A	N/A	Medium	2
UC-GK1	Integrated	±0.12 in	None	40 lbf	0	N/A	N/A	Medium	4
UC-GK2	Integrated	±0.16 in	None	220 lbf	2	3/8	Checked	Medium	4
UC-GL2	Integrated	±0.16 in	None	500 lbf	2	3/4	Checked	Heavy	N/A
UC-GL3	Integrated	±0.16 in	None	1000 lbf	4	3/4	Checked	Heavy	4
UC-GL5	Integrated	±0.16 in	None	500 lbf	2	1/2	Checked	Heavy	4
UC-GL6	Modular	±0.3 in	Automatic	N/A	4	1	Pass Thru	Heavy	4
UC-GL7	Modular	±0.3 in	Automatic	N/A	1	3	Pass Thru	Heavy	3

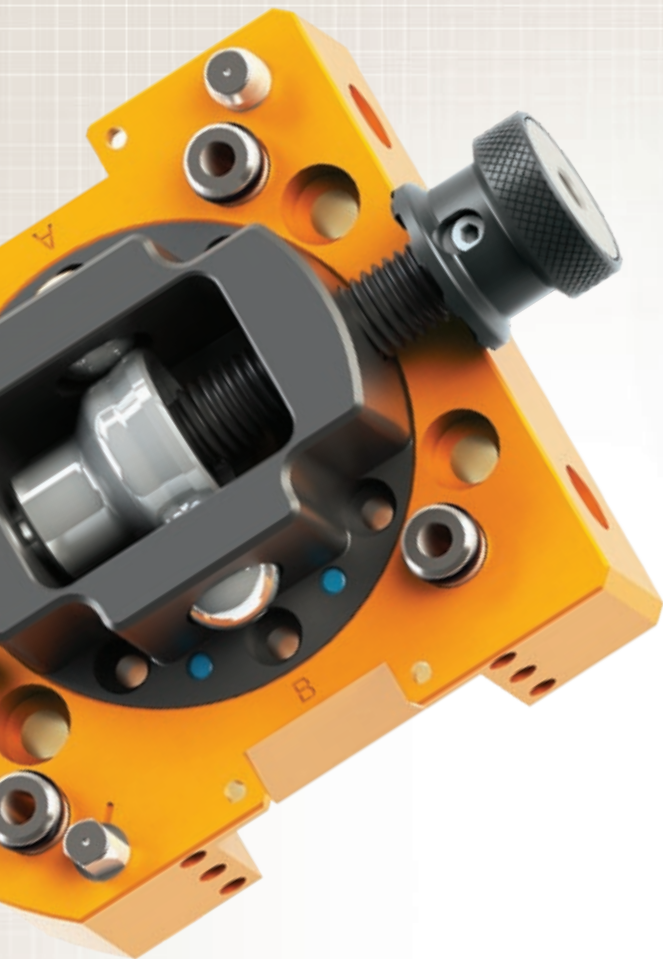

Manual Tool Changers Simpler, stronger, and more precise.

Product Description

Manual Tool Changers provide automated processes with a cost-effective solution for quickly changing tools by hand. The design combines high strength and excellent repeatability in an easy-to-use device that can also pass utilities. All Manual Tool Changers include multiple fail-safe features, including a patented screw-cam locking mechanism that prevents loosening due to vibrations. The fully-threaded



all-steel locking mechanism couples the Master and Tool plates together using a ratchet knob for a high security connection that is simple to use.

Product features include a compact and robust design, integrated pneumatic ports, and exterior mounting flats to connect a wide range of utilities such as air, fluid, electrical signals and more. Manual Tool Changers are fully compatible with ATI's Utility Module products.

One-Piece Tool—Hardened steel tool-side couples securely with excellent repeatability

Precision Locking Mechanism—Hardened steel screw-cam and locking balls produce high coupling strength

Ratchet Knob—For quick, secure locking; no tools required

Pass Pneumatics and Electrical—Integrated pass-through pneumatic ports; mounting flats for adding ATI Utility Modules

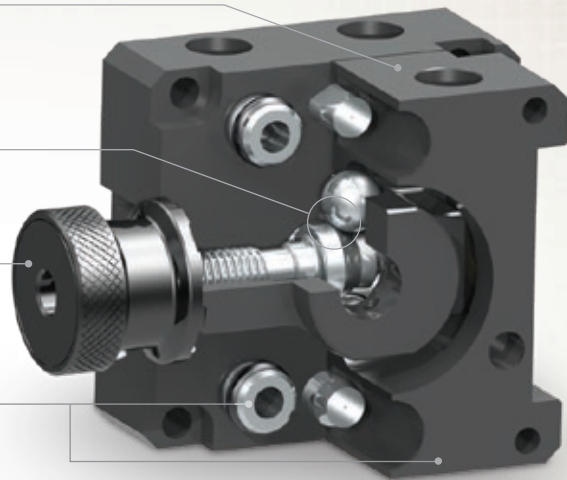

How To

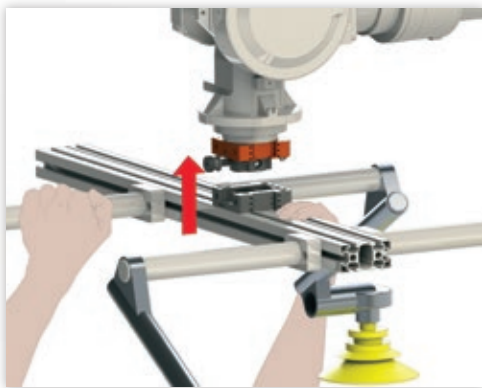

Bring tooling to Master

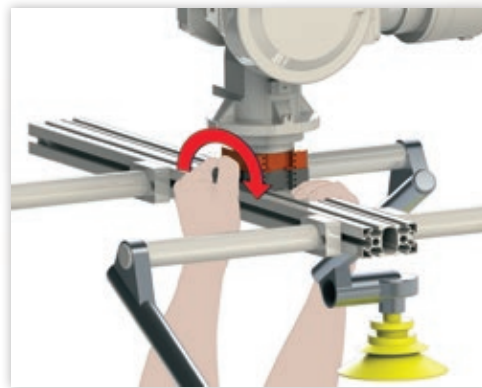

Tighten knob to secure – Unscrew knob to unlock

Specifications

MODEL	Suggested Payload Limit	Static Moment Capacity (X and Y)	Static Moment Capacity (Z)	Pneumatic Pass-Thru Ports (Qty) Size
MC-10*	11 lb (5 kg)	33 lbf-in (3.7 Nm)	110 lbf-in (12.4 Nm)	(4) M5 or #10-32 Air Only
MC-16R	35 lb (16 kg)	220 lbf-in (25 Nm)	400 lbf-in (45.2 Nm)	(4) 1/8 NPT
MC-36R	80 lb (36 kg)	1000 lbf-in (110 Nm)	1500 lbf-in (169 Nm)	(6) 1/8 NPT

*The MC-10 model is for collaborative robot applications only



Robotic Collision Sensors

Standard auto reset helps avoid downtime.

Product Description

ATI's Robotic Collision Sensor, or crash protection device, is designed to prevent costly damage to robotic end-effectors that results from robot crashes. The Collision Sensor's features include automatic reset, high repeatability, large moment deflection and torsional rotation, rugged design and low cost. The Collision Sensor's capabilities and features make it an excellent investment to protect robots and tooling while minimizing downtime after a crash and eliminating the need for human intervention to reset equipment. The unit has been tested to operate over millions of cycles without failure.

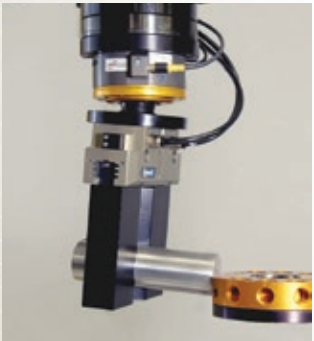

Product Highlights

High Repeatability: Following a collision, the use of precision components enables the Collision Sensor to reset to within 0.001 inches of its original position.

Generous Range of Motion: During a crash the Collision Sensor can comply large distances in response to any type of crash (angular, axial or torsional), thus allowing the robot controller ample time to take corrective action.

Energy Absorption: The impact energy generated during a collision is absorbed by a pneumatic chamber. This protects the tooling from being damaged by crashes. After absorption, this energy is redirected to automatically reset the device upon removal from the crash-causing object.

Consistent Break-away Response: At a given pressure the breakaway response is consistent, independent of the direction of the crash.

Convenient Mounting Surfaces: Threaded and through-hole mountings are provided for added flexibility. The simple mounting patterns reduce the stack height.

Cost-effective: The Collision Sensor is a strong, reliable, low-cost unit engineered to enhance manufacturing productivity and protect valuable robot end-effectors.

Automatic Reset: After a crash, the Collision Sensor will self-reset when the robot removes the tooling from the crash situation, reducing human-machine interaction.

Optional Spring Provides Two Trip Points: Air pressure may be used to obtain a higher break-away point during high-inertia motion and the optional preset spring only for a lower break-away point. Inquire about the range of preset springs available for each model.

Quick-Response Crash Detection: Dual trip points can be configured in multiple ways to prevent accidental signal trips.

Robust Design: The Collision Sensor is designed with generous use of hardened tool steel in contact and wear areas, to ensure the unit's long-life and strength.

Environmental Protection: Optional environmental protection boots are available to prevent water or oil-based machine coolants or sparks and weld spatter from entering the unit.

Optional Interface Plates: Blank or custom-configured interface plates are available for non-standard mounting patterns.



Angular Crash



Compressive Axial Crash



Torsional Crash

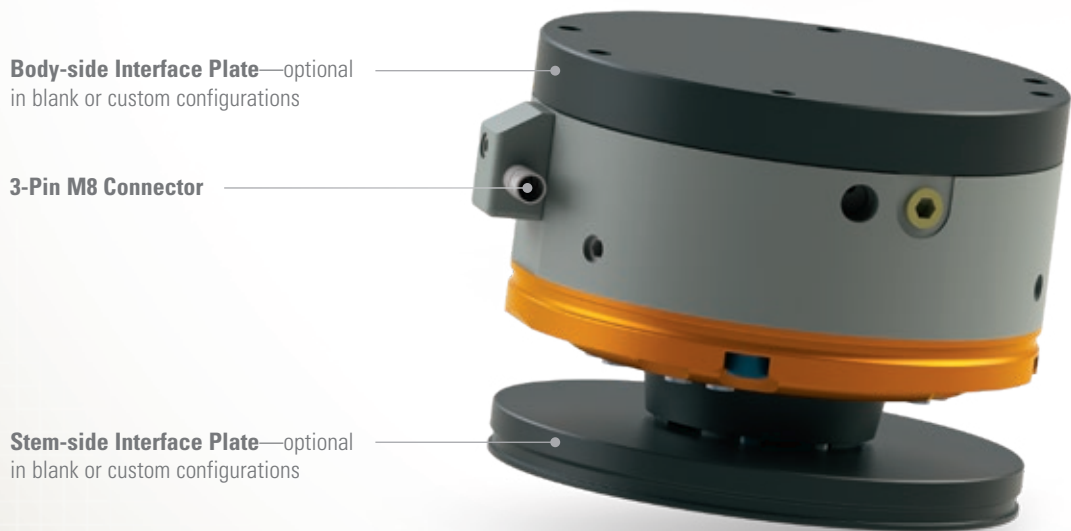
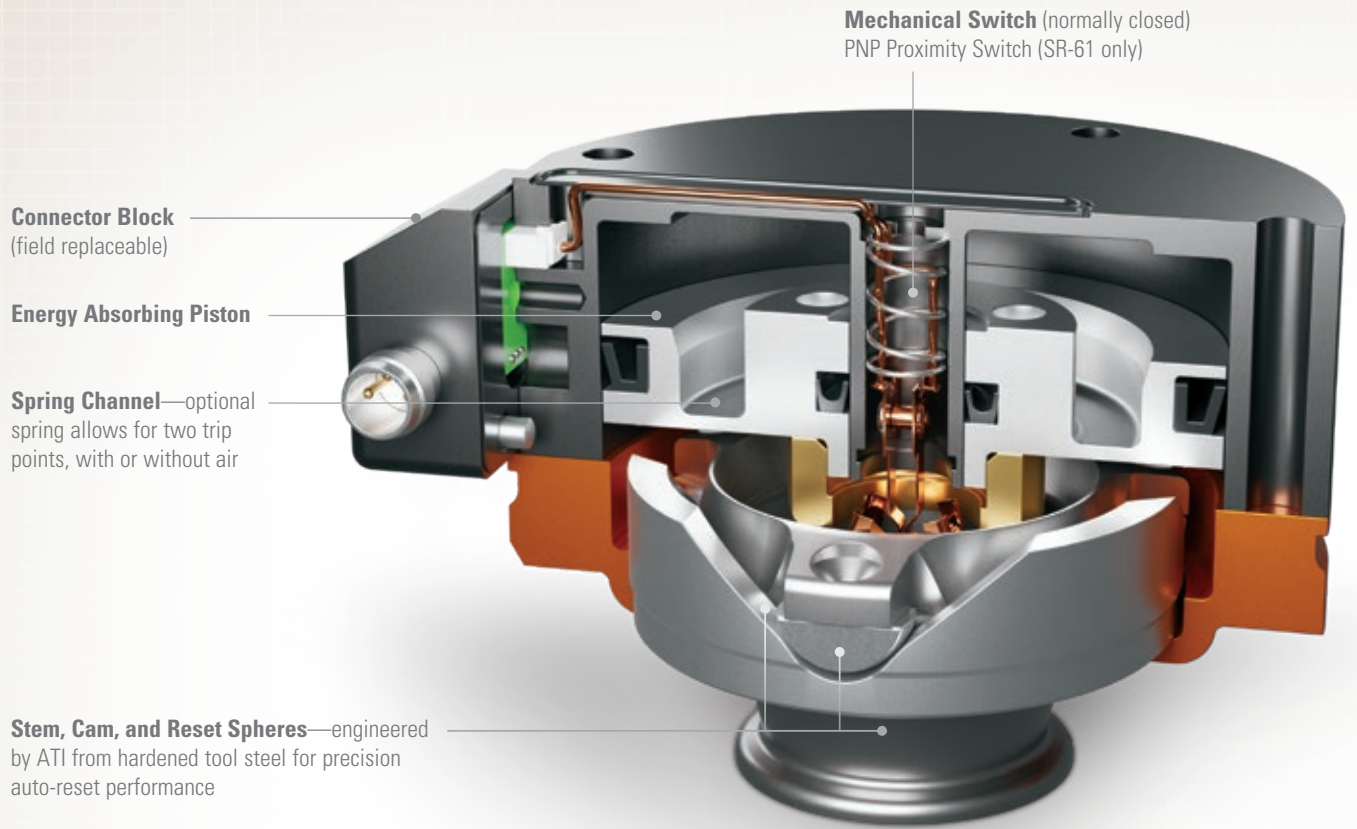

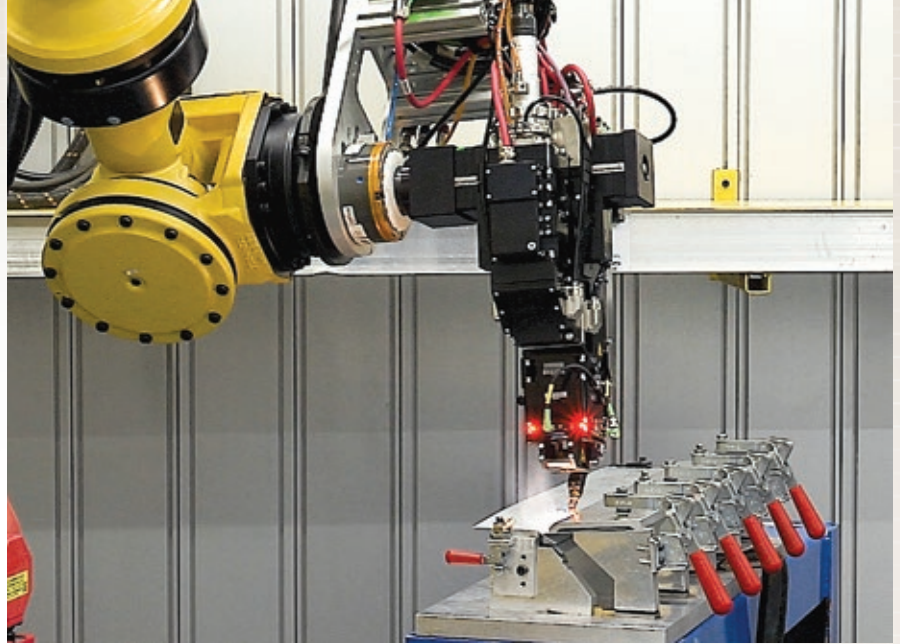

ATI Collision Sensor protects valuable laser welding tooling.

Specifications

MODEL	Angular Displacement	Torsional Displacement	Axial Displacement	Max. Air Pressure Setting	Weight	Moment Break-Away**	Torque Break-Away*	Axial Break-Away*
SR-48	±13°	±20°	0.2 in (5.1 mm)	90 psi (6.2 bar)	0.55 lb (0.249 kg)	20 lbf-in - 53 lbf-in (2.3 Nm - 6 Nm)	61 lbf-in (6.9 Nm)	100 lb (440 N)
SR-61	±11°	±20°	0.22 in (5.6 mm)	90 psi (6.2 bar)	0.7 lb (0.318 kg)	60 lbf-in - 250 lbf-in (6.8 Nm - 28 Nm)	220 lbf-in (24 Nm)	200 lb (880 N)
SR-81	±13°	±25°	0.34 in (8.6 mm)	90 psi (6.2 bar)	1.28 lb (0.581 kg)	120 lbf-in - 520 lbf-in (14 Nm - 59 Nm)	540 lbf-in (61 Nm)	380 lb (1700 N)
SR-82	±13°	±25°	0.34 in (8.6 mm)	90 psi (6.2 bar)	1.28 lb (0.581 kg)	120 lbf-in - 520 lbf-in (14 Nm - 59 Nm)	540 lbf-in (61 Nm)	380 lb (1700 N)
SR-101	±12°	±25°	0.4 in (10 mm)	90 psi (6.2 bar)	2.6 lb (1.18 kg)	240 lbf-in - 1100 lbf-in (27 Nm - 120 Nm)	1100 lbf-in (130 Nm)	610 lb (2700 N)
SR-131	±10°	±20°	0.46 in (12 mm)	90 psi (6.2 bar)	5.1 lb (2.31 kg)	670 lbf-in - 3000 lbf-in (76 Nm - 340 Nm)	2800 lbf-in (310 Nm)	1100 lb (4700 N)
SR-176	±10°	±20°	0.63 in (16 mm)	90 psi (6.2 bar)	12 lb (5.44 kg)	1600 lbf-in - 7100 lbf-in (180 Nm - 810 Nm)	7500 lbf-in (850 Nm)	2000 lb (8900 N)
SR-221	±8°	±20°	0.63 in (16 mm)	90 psi (6.2 bar)	25.1 lb (11.4 kg)	3900 lbf-in - 17000 lbf-in (440 Nm - 2000 Nm)	13000 lbf-in (1500 Nm)	3100 lb (14000 N)



Compliance Devices Compensate for process misalignment in multiple directions.

ATI offers three unique compliance devices that help compensate for misalignment in your process. These devices reduce design time and allow for more reliable processing in applications with tight tolerances. Compliance devices save you time and money while increasing efficiency.



UCC Universal Compliance Compensator

This device is named for its unique combination of compliance behaviors including X-Y Lateral, X-Y-Z Rotation, and Z Compression. After compliance, the UCC returns to its center repeatability by means of a pressurized internal reset piston. Compliance can be adjusted to suit different applications by varying the supplied air pressure. This offers flexibility for demanding applications such as automated assembly, bin picking, loading and unloading machines, and more.

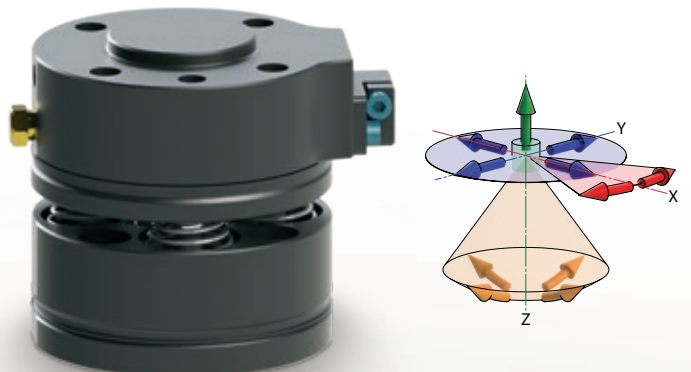

LCC Lateral Compliance Compensator

The LCC Lateral Compliance Compensator overcomes severe misalignment by providing X-Y lateral and Z axis compliance. The high endurance, high repeatability position compensation enables precise gripping and routing of parts in automated assembly, machine loading, and other applications.

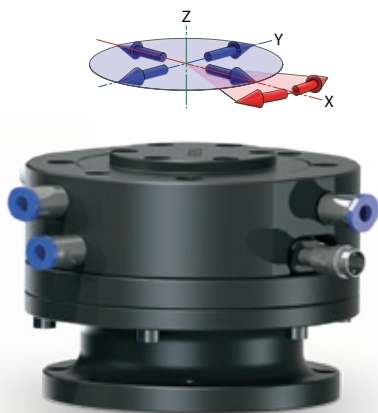

RCC Remote Center Compensators

The RCC Compensator is designed to correct alignment errors for peg-in-hole automated assembly applications. This device is engineered to project a compliance center (also known as center-of-compliance) forward by using three or more elastomer shear pads. The shear pads provide axial stiffness and lateral compliance. When the contact point is near the center-of-compliance, the part will automatically correct lateral and rotational misalignment, reducing the contact force and preventing galling and jamming.

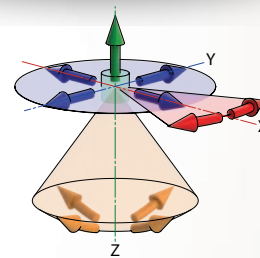

Specifications

MODEL	X-Y Lateral	X-Y Rotation	Z Rotation	Z Compression	Max. Payload
UCC – U1-050	■	■	■	■	11 lb
LCC – L1X-063	■		■		66 lb**
LCC – L1X-125	■		■		220 lb**
RCC – 001-A*	■	■	■		5 lb**
RCC – 111-B*	■	■	■		10 lb**
RCC – 211-C*	■	■	■		24 lb**
RCC – 213-C*	■	■	■		44 lb**
RCC – 413-C*	■	■	■		44 lb**

*Additional models available that cover a wide range of payloads and C-of-C specifications.

**In vertical position (robot wrist parallel to the ground).



Engineered Products for Robotic Productivity

www.ati-ia.com

© Copyright by ATI Industrial Automation, Inc. 2021.
All rights reserved. 9205-00-1025-01

