

2024



fetra[®]

●●●●

Transport equipment



ROLLERS & LIGHT TROLLEYS • TROLLEYS • TRUCKS • WHEELS • LIFTING CARTS

ALLIANCE SUPPLIES SDN.BHD.

www.alliance-supplies.com | www.alliancesuppliesonline.com.my | info@alliance-supplies.com | T:+606 3338889/8887/8898



➤	Introduction General facts about fetra / Quality features	2 – 10
➤	GREY EDITION A selection of topsellers in the trend colour antracite grey RAL 7016	11 – 20
➤	Rollers and light trolleys Dollies with gooseneck handles / Storeroom trolleys / Collapsible carts	21 – 29
➤	Trolleys MultiVario-Transporters / Table top carts / Workshop carts / Rolling desks / Shelved trolleys / Parcel carts	30 – 63
➤	ESD-Trolleys ESD-Trucks / ESD-Trolleys / ESD-Euro box carts	64 – 71
➤	Special trolleys Office trolleys / Box carts / Storeroom trolleys / Euro box carts / Super-MultiVario-Transporters / Trolleys with carrier spars / Sheet material transport	72 – 120
➤	Dump trucks Sheet metal dump trucks / Self-tilting boxes / Tipping containers	121 – 125
➤	Pallet transport Pallet dollies / Tugger train / Trolleys	126 – 131
➤	Hand carts Hand carts / Hand trucks	132 – 138
➤	Trucks Tubular steel trucks / Aluminium trucks / Stairway trucks / Compact hand trucks / Chair trucks / Trucks for appliances / Drum transport / Steel bottle trolleys	139 – 163
➤	Tyre transport Tyre trolleys / Tyre trucks	164 – 167
➤	Lifting carts Pallet trucks / Stackers / Lifting table carts / Machine lifters / Moving gears / Furniture lifting rollers / Angle rolls	168 – 178
➤	Wheels, Castors and Accessories Wheels / Swivel castors / Fixed wheel castors / Dead man brake / Electric drive unit / TOTALSTOP-central brake system / Platforms / Spare parts / Surcharge articles	178 – 186
➤	Index Keyword table	187

▶ **Table top carts with steel sheet**

in various versions



Page 37-38

▶ **ESD-Table top carts**

Platforms made of steel sheet flush and with rim



Page 67

▶ **Pallet dollies**

with polyurethane tyres



Page 127

▶ **Shelved trolleys**

with doors



Page 58

▶ **Compact hand truck "Wuppi"**

and accessories



Page 150

▶ **Wheels**

new wheels in exclusive fetra-design



Page 178-179



◀◀◀ fetra-Company film

► Quality made in Germany

fetra is a family-managed company that is clearly committed to the production site Germany. With a good feeling for engineering and material, we develop innovative transport devices in modern design. Our extensive range of more than 1,000 products reflects decades of manufacturing experience and is mostly all „Made in Germany“.



► Perfect workmanship guaranteed

fetra transport equipments are manufactured with highly efficient methods using the most advanced production facilities. Before they are powder-coated, all products undergo extensive pre-treatment by shot blasting. This environmentally friendly finish guarantees a long product lifecycle and permanent good looks. The result: Visibly perfect workmanship! We give you our word for it – and 10 years warranty on virtually all products!

► Excellent service and fast delivery

Perfect logistics! Our large warehouse and a sophisticated logistics system ensure short response times and fast delivery even in times of high workload. We are only satisfied once you are happy!



» fetra on the Web

Visit us on the Internet and find detailed information, products films, photos and PDF data sheets to download and forward. Discover useful services in our new log in area. Use this year's brand new chat function or just ask us questions and give us feedback! Go directly to www.fetra.com



» Catalogue Portal

All our printed documents in digital form. View catalogues, brochures and flyers as practical online flip documents or download them as PDF files. Collect single pages with the paperclip function and forward them. www.fetra.de/en/catalogue



» Media Library

Discover application films for several fetra products and watch our trucks and trolleys in action!

www.fetra.de/en/service/mediathek

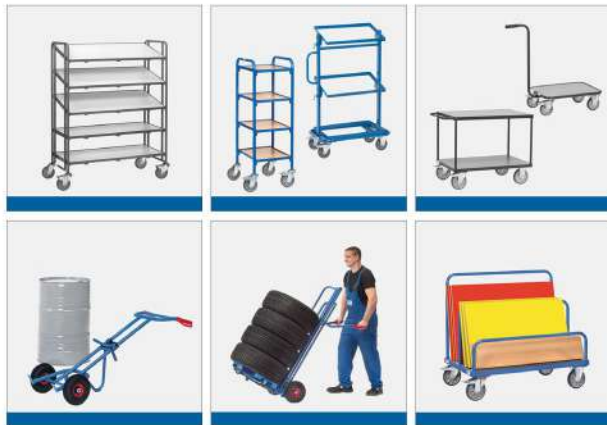

» Themed Worlds

Experience fetra products sorted by the needs of special target groups. See e.g. transport solutions for drum transport or the automotive sector at a glance in categories.

www.fetra.de/en/themedworlds



» Support and advice on Site

Our mission is to offer a solution for every in-house transport problem! Our factory-trained sales partner in your area will be glad to assist you!

www.fetra.de/en/sales-partners





Watch modular system film >>>

> Variety and functionality

Many fetra transport devices are available in a modular system. The system components are simply inserted and secured with bolts. This allows you to change, swop and add-on in many ways with the fetra MultiVario-System. Thanks to this fetra „Insert & Bolt Principle“ with 2-point support, the stability matches that of any welded structure!



> Platform sizes

Length x Width

Platform size: 850 x 500 mm

Platform size: 1.000 x 600 mm

Platform size: 1.000 x 700 mm

Platform size: 1.200 x 800 mm

> Wheels

Easy-running TPE-castors with groove ball bearing. Very low starting, rolling and swivelling resistance. Tyres non-marking = trackless. Low running noise on level floors.

> Construction

Tubular steel and sectional steel welded, stylish frame structure with „round edges“.

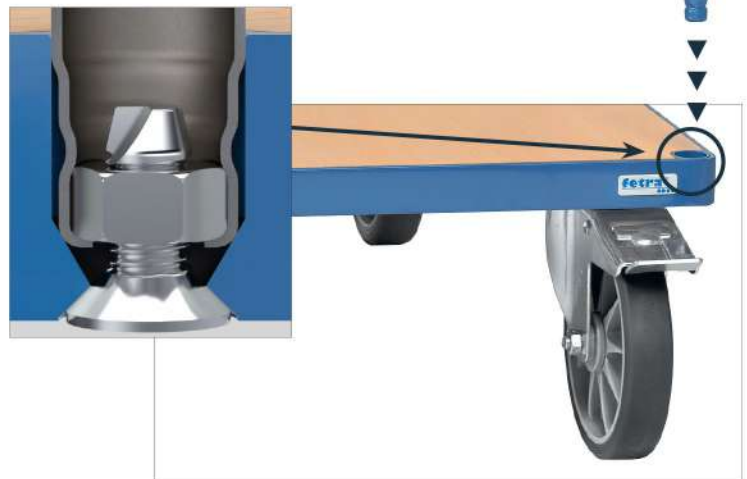

› Powder coating

The surface of our transport equipment is pretreated optimal by shot blasting. The elaborate procedure guarantees the perfect holding of the powder coating. The used quality powder is solvent-free and has a very high mechanical and chemical resisting. These high value finish guarantees long product lifecycle and permanent good looks.



› Versions

Different choices possible



› Accessories

- Protective edge
- Protective wheels
- Clip board
- Wire basket
- Softgrip push handle
- Dead man brake
- Collapsible hinge
- Electric drive unit
- Waterproof platform
- Rigid PVC panel
- Scanner holder
- Waste collector
- Bottle holder
- Paper roll holder
- Shaft and tow hitch
- Alternativ wheel equipments
- And many more ...

› Side components

- Panelled end made of wood
- Panelled end made of wire mesh
- Push handle
- Stanchions
- And many more ...





As standard equipment: the fetra – TPE castor

Wheels with TPE tyres (thermoplastic elastomer) have many benefits on level floors. The force required for transporting is minimised: with very little effort. Even heavy loads can be moved comfortably, safely and at low noise. The TPE castor with precision groove ball bearings in the appealing fetra design is compliant to EU regulation 1272/2013 PAH (Polycyclic Aromatic Hydrocarbon).



- › Very low starting, rolling and swivelling resistance
- › Low noise operation on level floors
- › Dark-grey tyre, dirt-resistant
- › Tyres are non-marking, despite their dark colour (trackless)
- › Maintenance-free groove ball bearing sealed on both sides
- › PAH compliant to the EU regulation 1272/2013
- › Thread protection prevents threads from wrapping around the wheel axle
- › Appealing and individual fetra design

(European design protection law © EU 00134689.4-001/00134689.4-003)



TOTALSTOP – the fetra central brake system

Innovative, comfortable, ergonomic and safe: This brake system developed by fetra can be easily locked or released with only one foot. Apart from the rotation of the wheels, also the swivelling movement of both swivel castors is securely locked. This avoids hazardous situations by preventing the braked cart from swinging sideways. Due to its central location, the brake pedal is always visible to the operator and can be operated in any position of the castors. The rubber wheel locking device is effective on all tyre materials and can be very easily readjusted.



- › **Innovative**
With only one push of the foot, the rotation of the wheel and swivelling movement of both swivel castors are blocked
- › **Comfortable**
The brake pedal always remains in the operator's field of vision. Braking is possible in any position of the castors
- › **Ergonomic**
Easy release of brake due to high ground clearance of pedal
- › **Secure**
Wheel locking device made of rubber. Maximum braking performance on all tyre materials, easy to readjust
- › **European patent EP 2743097**



Surcharge see page 183

For all transport trolleys marked with the TOTALSTOP logo.

ALLIANCE SUPPLIES SDN.BHD.

➤ **FIXSTOP - the new fetra central directional locking**

FIXSTOP is the particular comfortable directional locking by fetra. Instead of the 2 standard fixed-wheel castors 2 synchronous lockable swivel castors. The swivelling movements of both swivel castors can be fixed comfortable by operation of the central foot step bar from any longitudinal side in a grid of 4 x 90°. Thereby, with only one push of the foot the operator gets the choice between the manoeuvrability of a cart with 4 swivel castors and the directional stability of a cart with 2 swivel and 2 fixed-wheel castors. Operatable in any wheel position.

Surcharge per set for trolleys with TPE-tyres from 450 mm width.



- **Central operatable**
The FIXSTOP foot step bar can be operated from both longitudinal sides with only one push of the foot.
- **Flexible**
360° manoeuvrability and locking to fixed-wheel castor as needed.
- **Innovative**
Lean and modern design.
- **German patent 10 2016 110 300**

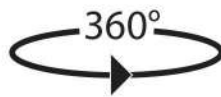

Foot step unlocked

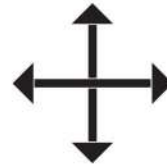

Foot step locked

Surcharge see page 184

For all transport trolleys marked with the FIXSTOP logo.

➤ **fetra-single directional locking device**

The conventional directional locking system by fetra. Instead of the 2 standard fixed-wheel castors 2 individual lockable swivel castors. The swivelling movements of these swivel castors can be locked each individually from one longitudinal side each by operation of the fixed operating levers in a grid of 4 x 90°. Thereby, a good straight run in longitudinal and transverse direction becomes possible. Operatable in any wheel position.

Surcharge per set for trolleys with TPE-tyres.



- **Individually operatable**
Thereby, individual adjustable according to wish.
- **Flexible**
360° manoeuvrability and locking to fixed-wheel castor as needed.
- **Kick lever convertable**
Kick lever in standard lateral operatable. On reconstruction of the castor by 180° also operatable from the end side.
- **German patent 10 2016 110 300**

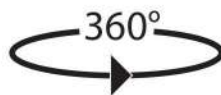

Operating lever unlocked

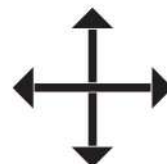

Operating lever locked

Surcharge see page 184



	TPE tyres	Polyamide wheels	Pneumatic tyres	Solid rubber tyres
Starting, rolling and swivelling resistance	Very low	Very low	Medium	Low
Running noise	Low on level floors	High on virtually all floors	Extremely low on all floors	Low on virtually all floors
Elasticity	Less smooth running	Inflexible hard running	Very smooth running	Smooth running
Sensitivity to soiling	Not sensitive	Very sensitive	Not sensitive	Not sensitive
Bearing	Part. smooth-running groove ball bearing	Smooth-running roller bearing	Smooth-running roller bearing	Smooth-running roller bearing
Capacity	For medium load capacities	For medium to high load capacities	For low to medium load capacities	For medium load capacities
Trackless	Non-marking (trackless)	Non-marking (trackless)	Optionally trackless tyres available	Optionally trackless tyres available
Floor characteristics	Suitable for level floors	Suitable for level floors	Suitable for level and slightly unlevel floors	Suitable for level and slightly unlevel floors
Conclusion	Cost-effective and easy-running wheel set for level floors; trackless even for sensitive flooring	Cost-effective wheel set with high load capacity, very low comfort; mostly resistant to moisture, salt, acidic and alkaline liquids	Ideal for poor ground conditions, in particular outdoors	Cost-effective wheel set for medium load capacities and universal usage
Cost	Standard wheel set – no surcharge see page 180	Surcharge on standard wheel set see page 184	Surcharge on standard wheel set see page 184	No longer available as standard



	Electrically conductive TPE tyres	Blue-grey solid rubber tyres	Polyurethane tyres	Elastic tyres
Starting, rolling and swivelling resistance	Very low	Low	Very low	Low
Running noise	Low on level floors	Low on virtually all floors	Low on virtually all floors	Extremely low on all floors
Elasticity	Less smooth running	Smooth running	Smooth running	Very smooth running
Sensitivity to soiling	Not sensitive	Very sensitive	Medium sensitive	Not sensitive
Bearing	Part. smooth-running groove ball bearing	Smooth-running roller bearing	Particularly smooth-running groove ball bearing	Particularly smooth-running groove ball bearing
Capacity	For medium load capacities	For medium load capacities	For high load capacities	For high load capacities
Trackless	Non-marking (trackless)	Non-marking (trackless)	Non-marking (trackless)	Non-marking (trackless)
Floor characteristics	Suitable for level floors	Suitable for level and slightly unlevel floors	Suitable for level and slightly unlevel floors	Suitable for level and slightly unlevel floors
Conclusion	Special wheel set for prevention of static charge	Cost-effective wheel set for medium load capacities; trackless even for sensitive flooring	Particularly high-quality and resistant wheel set for high load capacities; resistant against many aggressive materials	Highly comfortable due to easy, very smooth running; good for frequent crossing of edges and sills; high durability
Cost	Surcharge on standard wheel set see page 184	See page 181	Surcharge on standard wheel set see page 184	Surcharge on standard wheel set see page 184

What to consider?

A high-quality wheel set is essential for the successful application of a transport device according to its intended use. This is why fetra uses various tyres and bearings – depending on the ground, indoor and/or outdoor, transport weight or special requirements such as electrical conductivity, chemical resistance or wear characteristics.

fetra transport trolleys are standard-fitted with swivel castors and fixed-wheel castors with TPE tyres and groove ball bearings. Additionally, wheels and castors for virtually any field of use are available. Selecting the right option depends on the specific application, ground characteristics and transport weight.



Bush bearing

Simple and robust wheel bearing. Impact-resistant. Bushing made of polyamide. Corrosion-resistant, suitable for wet conditions. Under normal usage conditions maintenance-free. For devices with low speed and low usage intensity.



Roller bearing

Robust and durable wheel bearing. Impact-resistant. Low bearing friction. Permanent lubrication with long-life grease, under normal usage conditions maintenance-free. Well-proven bearing system for transport device castors.



Groove ball bearings

Highly robust precision wheel bearing. Impact-resistant. Very low bearing friction, permanent lubrication with long-life grease, mostly maintenance-free. Suitable for high load capacities and higher speeds.